

ILC15220503L REV B ECN 5049
SCALE 1.000

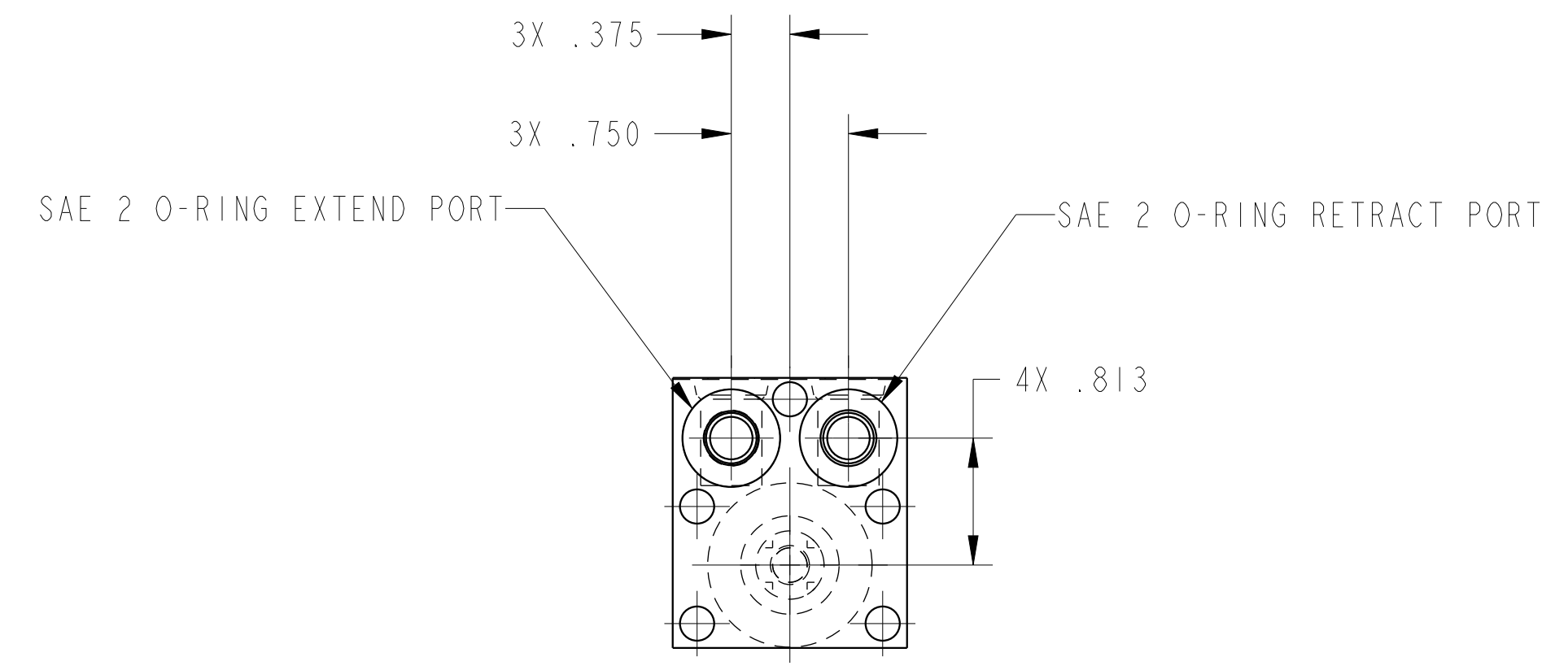

CAD CONTROL
DRAWING

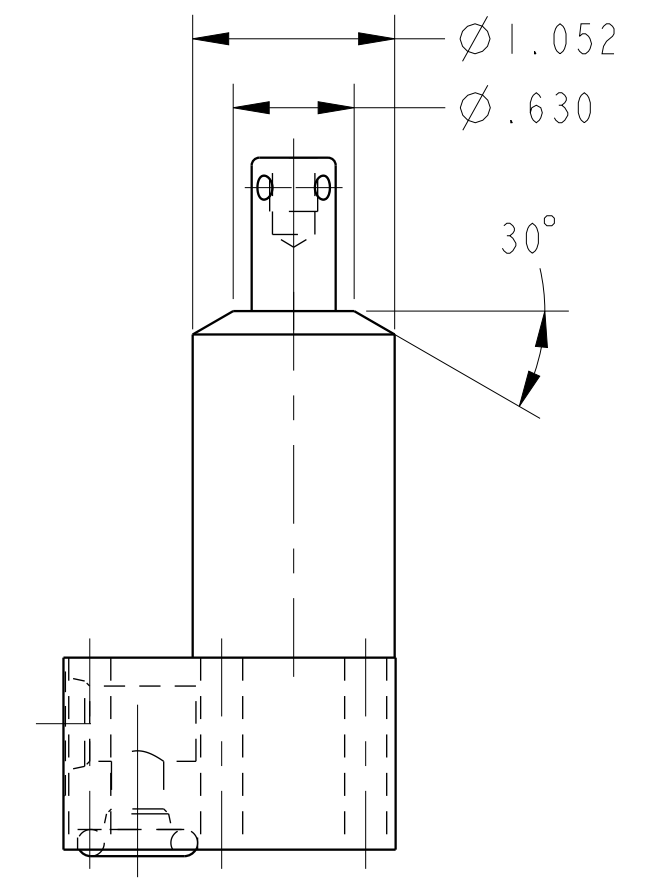
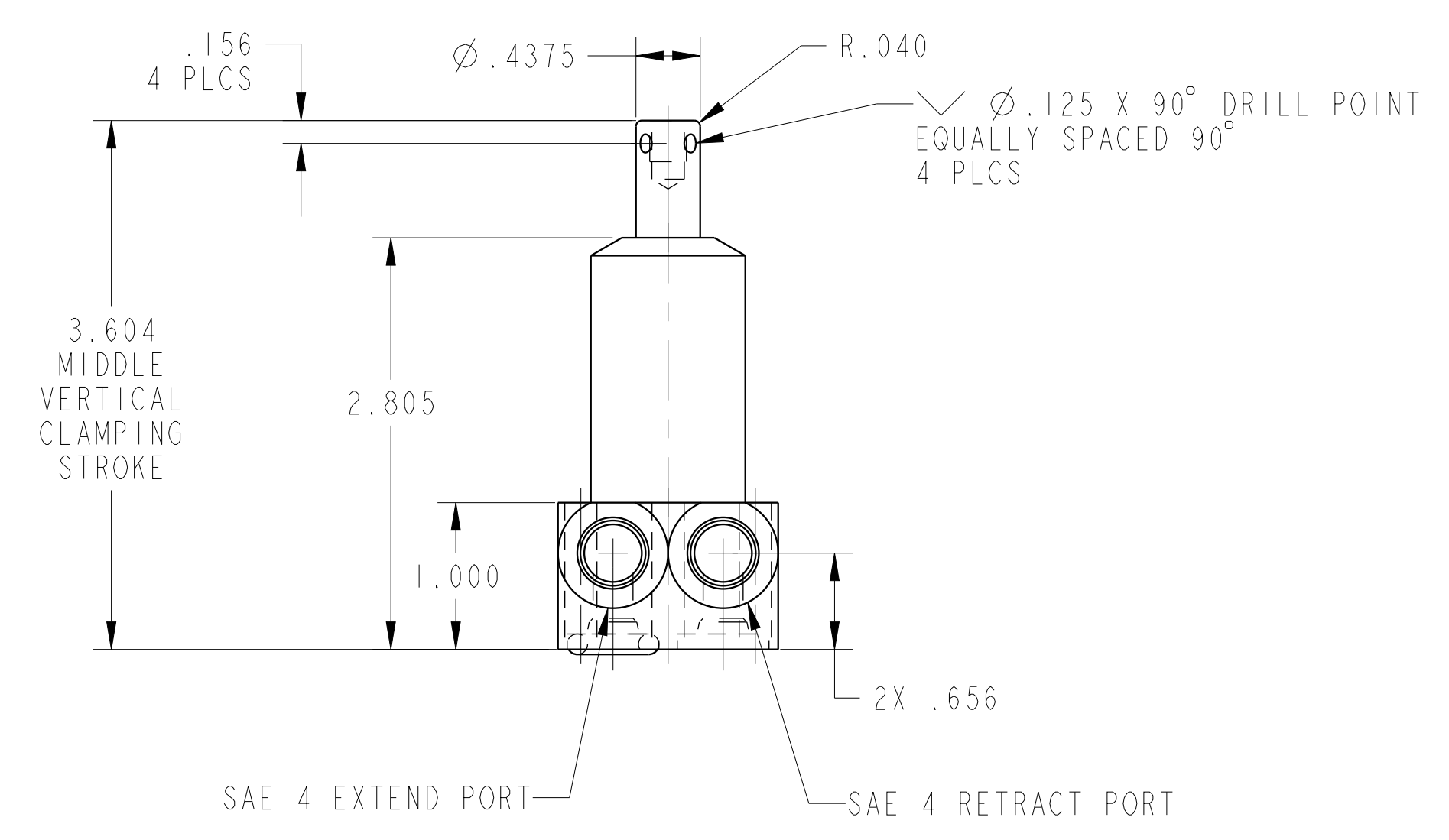
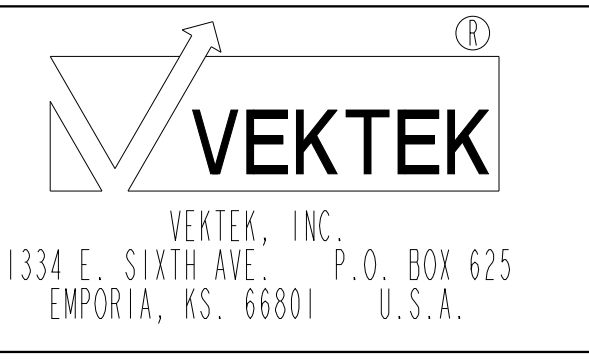

B	5049	RELEASE	JDW	03/06/23
REV	IN ACCORDANCE WITH ECN	EFFECTIVE DATE	REVISED BY	DATE
DRW BY:	RLK	DRAWING STATUS: Released		
DATE:	2/20/22	PRODUCTION APPROVED FOR RELEASED STATUS ONLY		

15220503L	A	SC, BF, 450, DA, LH
REFERENCE MODEL	REF REV	***
TOLERANCES DO NOT APPLY DIMENSIONS ARE NOMINAL		SIZE D

ILC15220503L	REV B
FORM FEG036, Rev. B	