

I LCMV41621830 REV B ECN 5240

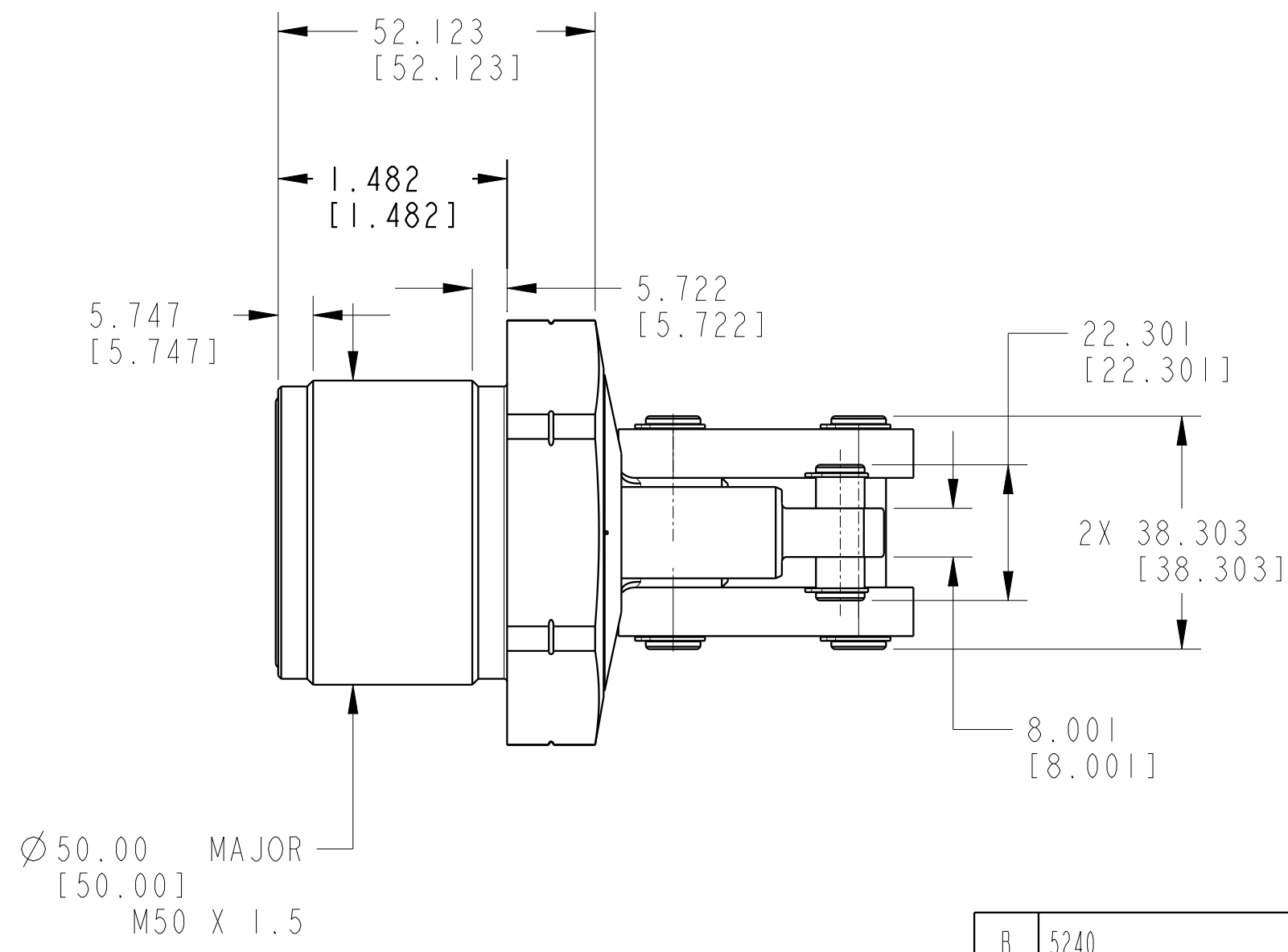

CAD CONTROL DRAWING

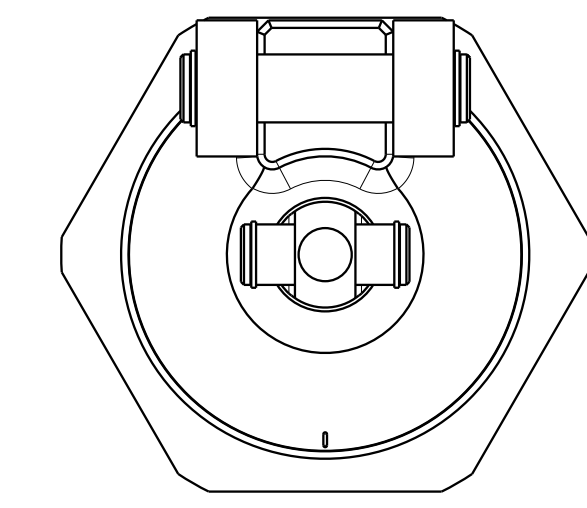
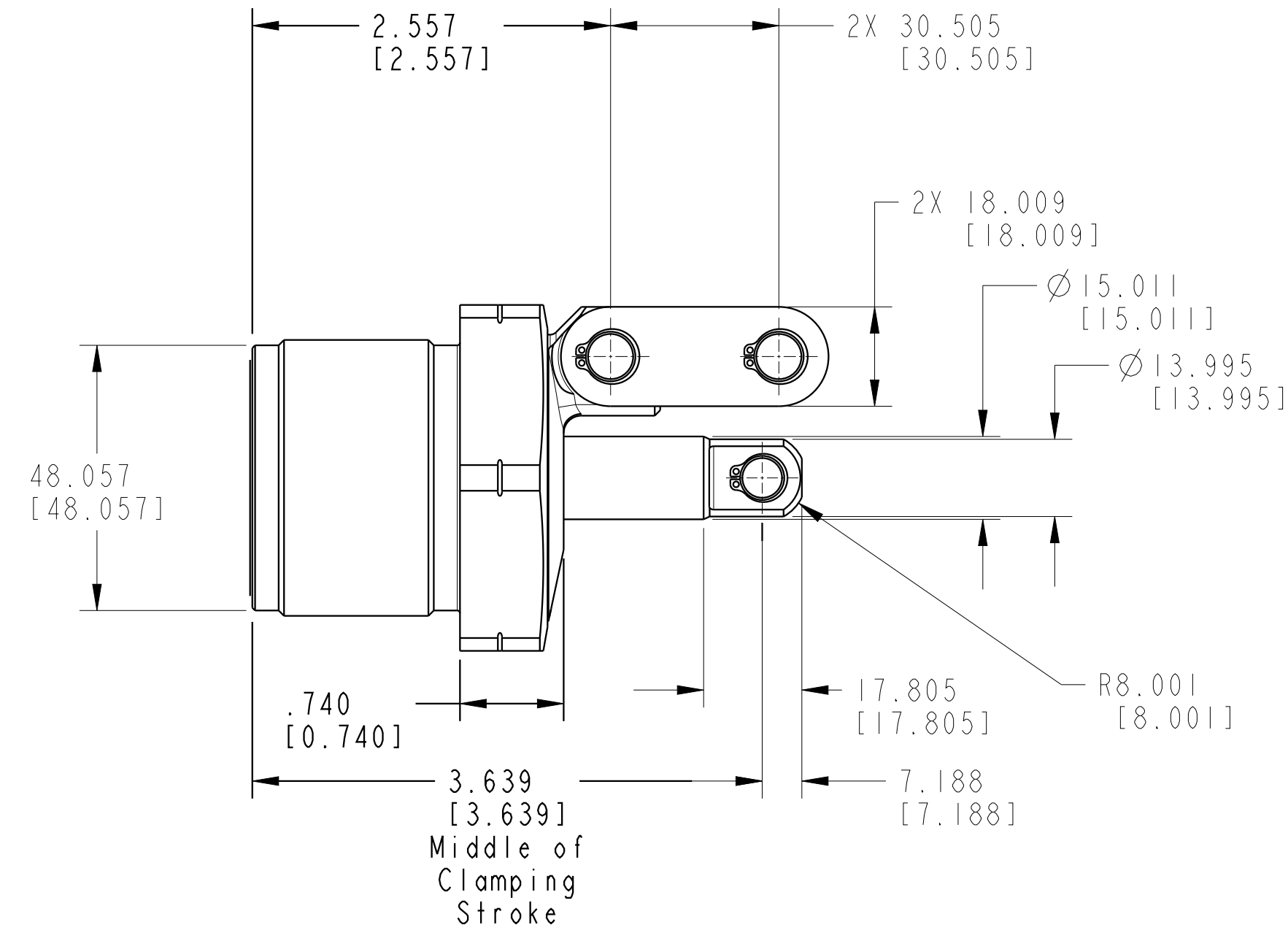

B	5240	RELEASE	BDC	2/23/24	41621830	A	I LCMV, LC, CM, TL360, DA, 7.56kN
REV	IN ACCORDANCE WITH ECN	EFFECTIVE DATE	REVISED BY	DATE	REFERENCE MODEL	REF REV	
DRW BY:	A.THOMSEN	DRAWING STATUS: Released			TOLERANCES DO NOT APPLY	UNITS	SIZE
DATE:	25-MAY-2020	PRODUCTION APPROVED FOR RELEASED STATUS ONLY			DIMENSIONS ARE NOMINAL	mm (inch)	D
							I LCMV41621830
							REV B