

NO	QTY	PART NO	DESCRIPTION	SEAL KIT
1	1	21510000	NUT, JAM, HEX, M8-1.00	
2	3	23350085	SPRING, COMPRESSION	X
3	3	23650009	BALL, TUNGSTEN-CARBIDE, 4mm	X
4	2	39051079	O-RING, (6mm X 1)	X
5	1	39051081	O-RING, (26mm X 2)	X
6	2	39051087	O-RING, (4mm X 3)	X
7	1	39053041	SEAL, WIPER, SNAP IN, WED, 15, 94A, AU	X
8	1	39056001	SEAL, STEP, ROD, 15	X
9	1	39056021	SEAL, CAP, PISTON, 25, 90A, AU GRPHT FLD	X
10	2	43068004	PLUG, SOCH, G1/8	
11	1	81400121	PLUNGER, SC, 7MPa, 25B, STR	
12	1	81400151	CAP, LC/SC, 7MPa, 25B	
13	2	81400200	PLUG, MANIFOLD, 7MPa, M6	
14	3	81400202	PIN, STOP, BALL, METRIC, 4mm BALL	X
N/A	N/A	L6014250	KIT, SEAL, SC, 7MPa, 25B	NOTED

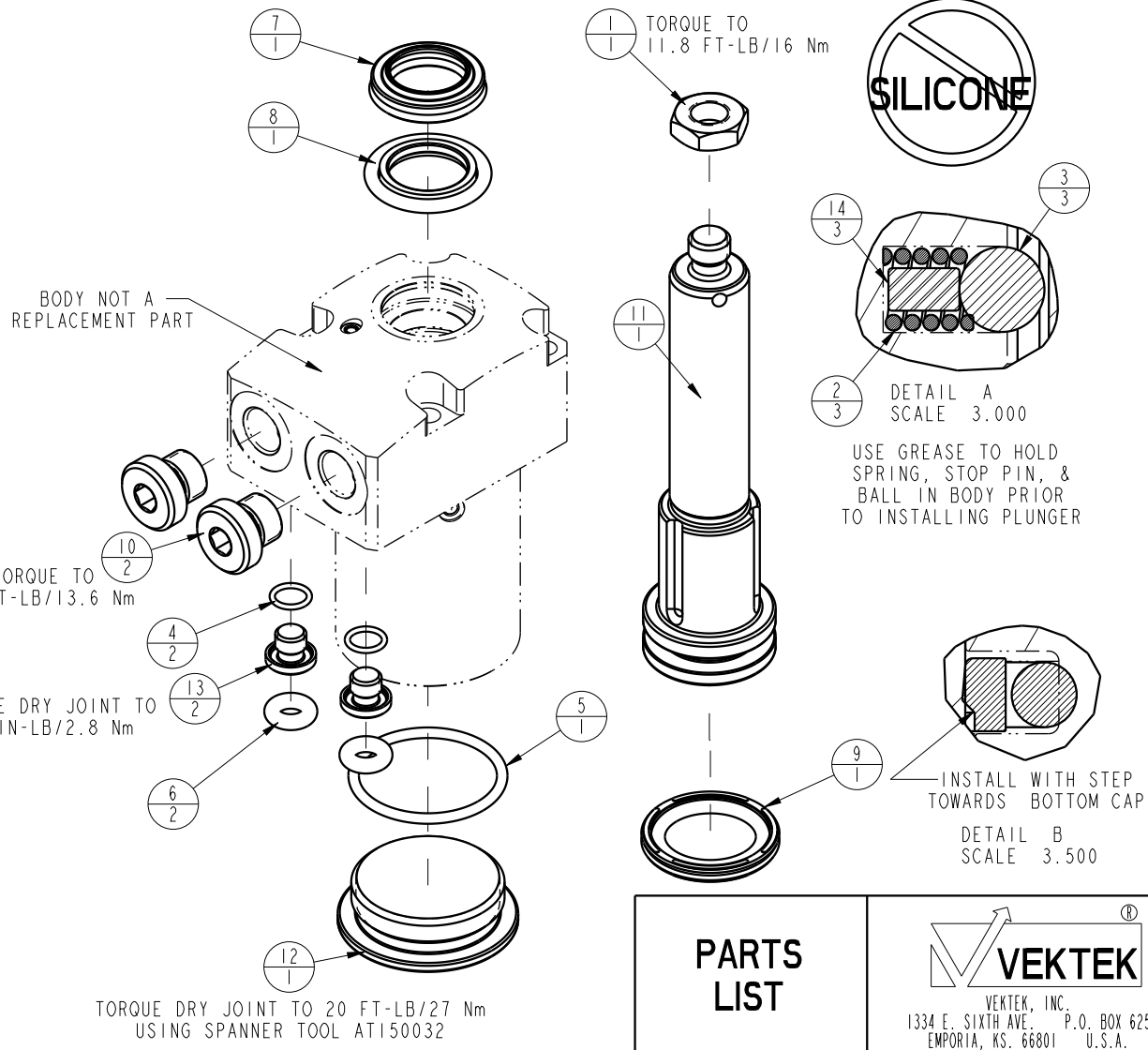

PARTS LIST	
	<small>VEKTEK, INC. 1334 E. SIXTH AVE. P.O. BOX 625 EMPORIA, KS. 66801 U.S.A.</small>
ASSEMBLIES AFFECTED L1402500S	PARTS LIST, ASSY, SC, TF, 7MPa, 25B, STR *****
SIZE A	LPL1448
	REV B

B	3273	RELEASE	JDW	08/15/18
REV	IN ACCORDANCE WITH ECN	EFFECTIVE DATE	REVISED BY	DATE
DRW BY:	TWA	DRAWING STATUS: Released PRODUCTION APPROVED FOR RELEASED STATUS ONLY		
DATE:	9-15-16			