

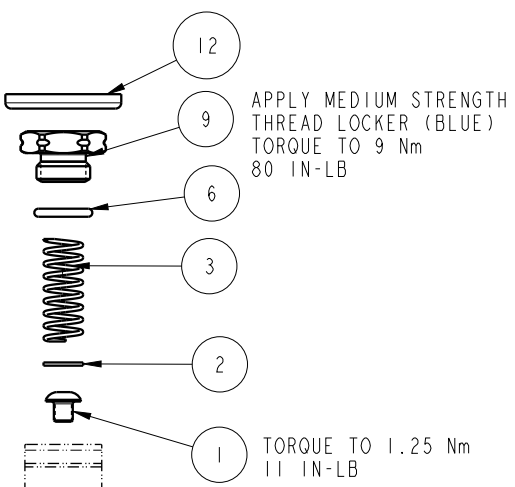

SEE ISI023 FOR SERVICE INSTRUCTIONS.
LUBRICATE ALL SEALS WITH CLEAN HYDRAULIC OIL
PRIOR TO ASSEMBLY.
DO NOT USE SILICONE BASED LUBRICANTS.

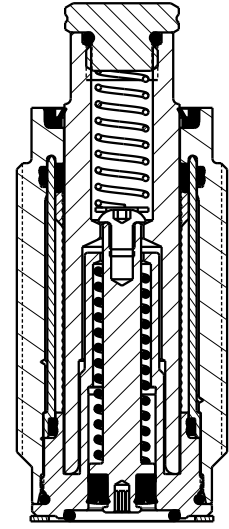

PLUNGER
These work supports are fully
rebuildable to full factory original
capacity by any authorized Vekttek repair
facility. All seals can be replaced by
any authorized repair facility.

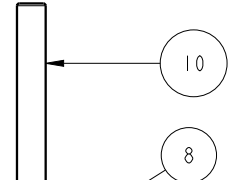
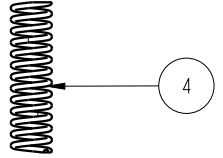
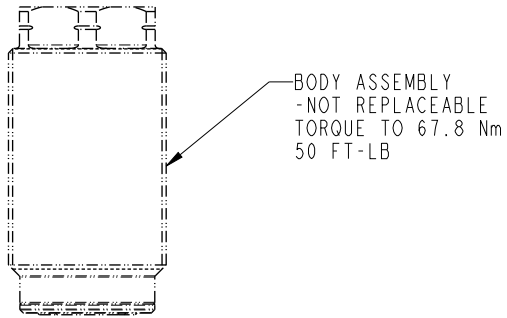

ASSEMBLE LIP
SIDE TOWARD
BOTTOM OF PISTON

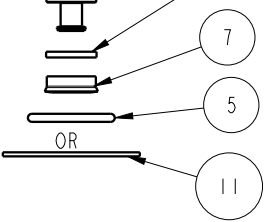

NO	QTY	PART NO	DESCRIPTION	STD SEAL KIT	SPRING KIT
1	1	21410075	BHCS, 8-32 x 3/16 SELFLOCK, SST		
2	1	21430001	WASHER		
3	1	23350083	SPRING, COMPRESSION		X
4	1	23355023	SPRING, COMPRESSION		X
5	1	39000061	O-RING, (-016)	X	
6	1	39002009	O-RING, (-012)	X	
7	1	39050028	SEAL, BEVEL, 3/16 X 7/16 X 1/8	X	
8	1	39054039	BU RING, (-201)	X	
9	1	41060802	BOLT, CONTACT, WS, 17.8kN		
10	1	81010815	PISTON, WS, FA, 3000 & 13.4kN, LS		
11	1	39H11062	GASKET, (-213)	X	
12	1	39V10023	WIPER, PRESS-IN, (3/4), VBGV	X	
N/A	N/A	60100134	KIT, SEAL, WS, FA, HC, 17.8kN	NOTED	N/A
N/A	N/A	61100225	KIT, SPRING, WS, FA, HC, 4000, LS	N/A	NOTED
N/A	N/A	ISI023	INSTRUCTION SHEET	N/A	N/A

PARTS LIST							
	VEKTEK, INC. 1334 E. SIXTH AVE. P.O. BOX 625 EMPORIA, KS. 66801 U.S.A.						
	ASSEMBLIES AFFECTED	PARTS LIST, ASSY, WS, FA, CM, HC, 17.8kN, LS					
REV	IN ACCORDANCE WITH ECN	EFFECTIVE DATE	REVISED BY	DATE	DROP-IN REPLACEMENT FOR 41007113		
DATE: 10/5/21	DRAWING STATUS: Released			PRODUCTION APPROVED FOR RELEASED STATUS ONLY	SIZE A	MPL1068	REV A
					FORM FEG035_PL_ASIZE, REV. B		

A	4631	RELEASE	RLK	2/28/22
REV	IN ACCORDANCE WITH ECN	EFFECTIVE DATE	REVISED BY	DATE
DRW BY: RLK	DRAWING STATUS: Released			
DATE: 10/5/21	PRODUCTION APPROVED FOR RELEASED STATUS ONLY			