

SEE IS1023 FOR SERVICE INSTRUCTIONS.
LUBRICATE ALL SEALS WITH CLEAN
HYDRAULIC OIL PRIOR TO ASSEMBLY.
DO NOT USE SILICONE BASED LUBRICANTS.

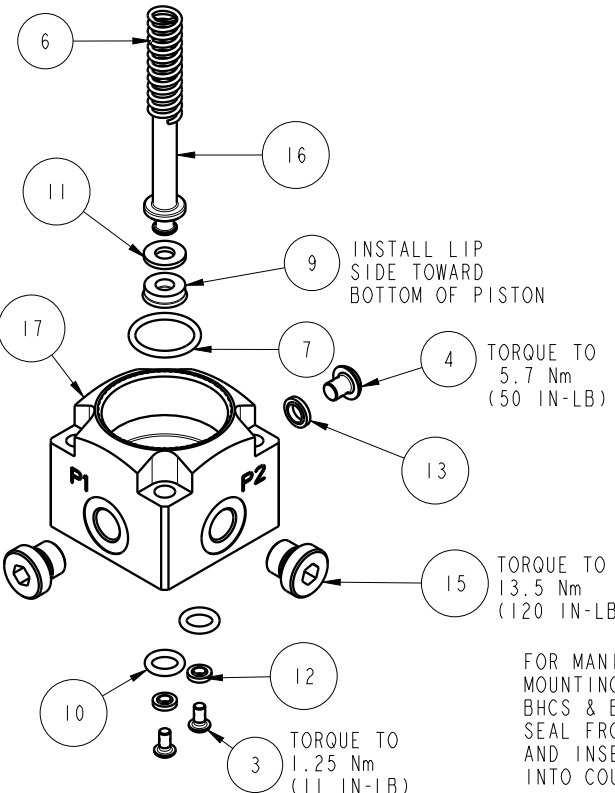

NO	QTY	PART NO	DESCRIPTION	STD SEAL KIT	SPRING KIT
1	1	21410075	BHCs, 8-32 x 3/16 SELFLOCK, SST		
2	1	21430001	WASHER		
3	2	21500019	SCREW, CAP, BTNH, M3 X 6, ALY		
4	1	21500046	SCREW, CAP, BTNH, M5-0.8 X 6, ALY		
5	1	23350083	SPRING, COMPRESSION		
6	1	23355023	SPRING, COMPRESSION		X
7	1	39000061	O-RING, (-016)	X	
8	1	39002009	O-RING, (-012)	X	
9	1	39050028	SEAL, BEVEL, 3/16 X 7/16 X 1/8	X	
10	2	39051116	O-RING, (6.8mm X 1.9)	X	
11	1	39054039	BU RING, (-201)	X	
12	2	39055011	SEAL, BONDED, M3		
13	1	39055013	SEAL, BONDED, M5		
14	1	41060802	BOLT, CONTACT, WS, 17.8kN		
15	2	43068004	PLUG, 1/8 BSPP		
16	1	81010815	PISTON, WS, FA, 3000 & 13.4kN, LS		
17	1	91040617	KIT, BASE, WS, FA, MM, HC, 17.8kN		
18	1	39V10023	WIPER, PRESS-IN, (3/4), VBGV	X	
N/A	N/A	60100134	KIT, SEAL, WS, FA, BM, HC, 17.8kN	NOTED	N/A
N/A	N/A	61100225	KIT, SPRING, WS, FA, HC, 4000, LS	N/A	NOTED
N/A	N/A	IS1023	INSTRUCTION SHEET	N/A	N/A

PARTS LIST

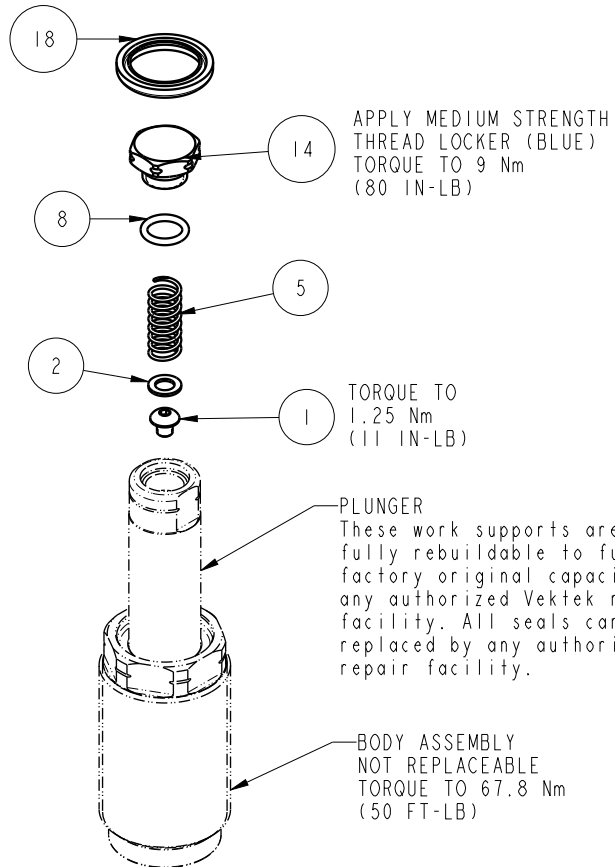
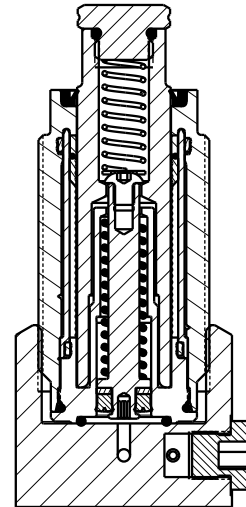

VEKTEK, INC.
1334 E. SIXTH AVE. P.O. BOX 625
EMPORIA, KS. 66801 U.S.A.

ASSEMBLIES AFFECTED
41080826

PARTS LIST, ASSY, WS, FA, BM, HC, 17.8kN, LS

SIZE
A MPL1069

REV
B

B	4993	RELEASE	RLK	12/7/22
REV	IN ACCORDANCE WITH ECN	EFFECTIVE DATE	REVISED BY	DATE
DRW BY:	RLK	DRAWING STATUS: Released		
DATE:	10/6/21	PRODUCTION APPROVED FOR RELEASED STATUS ONLY		