

SECTION A-A

NO	QTY	PART NO	DESCRIPTION	STD SEAL KIT
1	2	21500319	SCREW, SET, CUP PT, M6 X 1 X 12	
2	2	23050036	RING, RTNG, EXT, 0.394	X
3	4	23050037	RING, RTNG, EXT, 0.438	X
4	1	39051185	O-RING (-022), 1 X 1/16 X 1-1/8	X
5	1	39051186	O-RING (-031), 1-3/4 X 1/16 X 1-7/8	X
6	1	39052061	SEAL, ROD, RSD, 18, 85A, AU	X
7	1	39053042	SEAL, WIPER, SNAP IN, WED, 18, 94A, AU	X
8	1	39056033	SEAL, CAP, PISTON, 22.5, 94A, AU	X
9	2	81600148	LINK, LC, 7MPa, 50B	
10	2	81600153	PIN, LINK, LC, 7MPa, 50B	
11	1	81600158	PIN, PLUNGER, LC, 7MPa, 50B	
12	1	81600253	PLUNGER, LC, TL360, DA, 2400/10.4kN	
N/A	N/A	60160210	KIT, SEAL,	NOTED

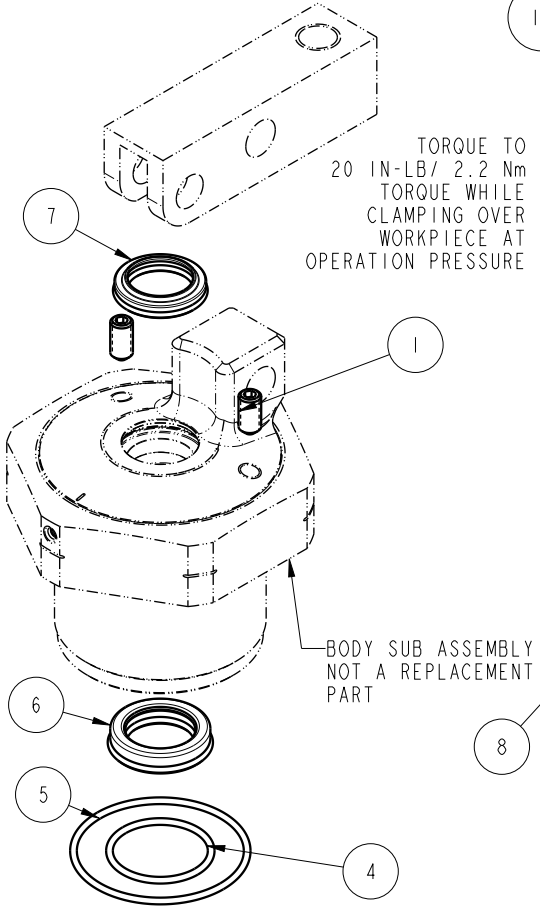
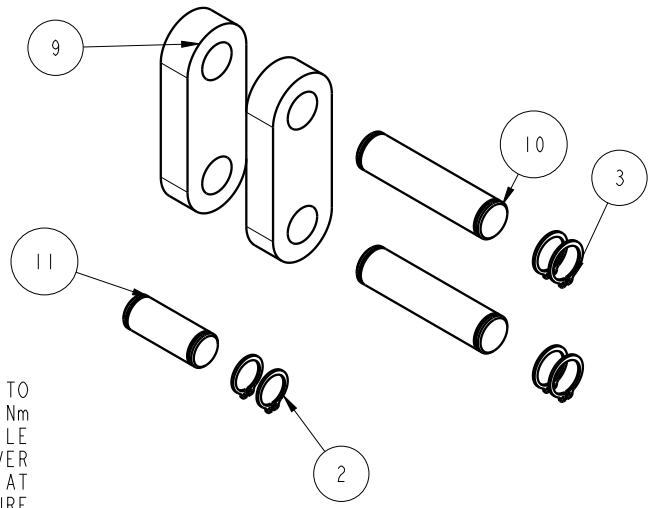

TORQUE TO
20 IN-LB/ 2.2 Nm
TORQUE WHILE
CLAMPING OVER
WORKPIECE AT
OPERATION PRESSURE

BODY SUB ASSEMBLY
NOT A REPLACEMENT
PART

GREASE PACKET
INCLUDED IN SEAL KIT

PARTS LIST	 VEKTEK, INC. 1334 E. SIXTH AVE. P.O. BOX 625 EMPORIA, KS. 66801 U.S.A.
	ASSEMBLIES AFFECTED 41622230
PARTS LIST, ASSY, LC, CM, TL360, DA, 10.4 kN	SIZE A
MPL1630	REV A

A	4723	RELEASE	BDC	7/19/2022
REV	IN ACCORDANCE WITH ECN	EFFECTIVE DATE	REVISED BY	DATE
DRW BY:	BDC	DRAWING STATUS: Released PRODUCTION APPROVED FOR RELEASED STATUS ONLY		
DATE:	07/20/22			

SHEET 1 OF 1