

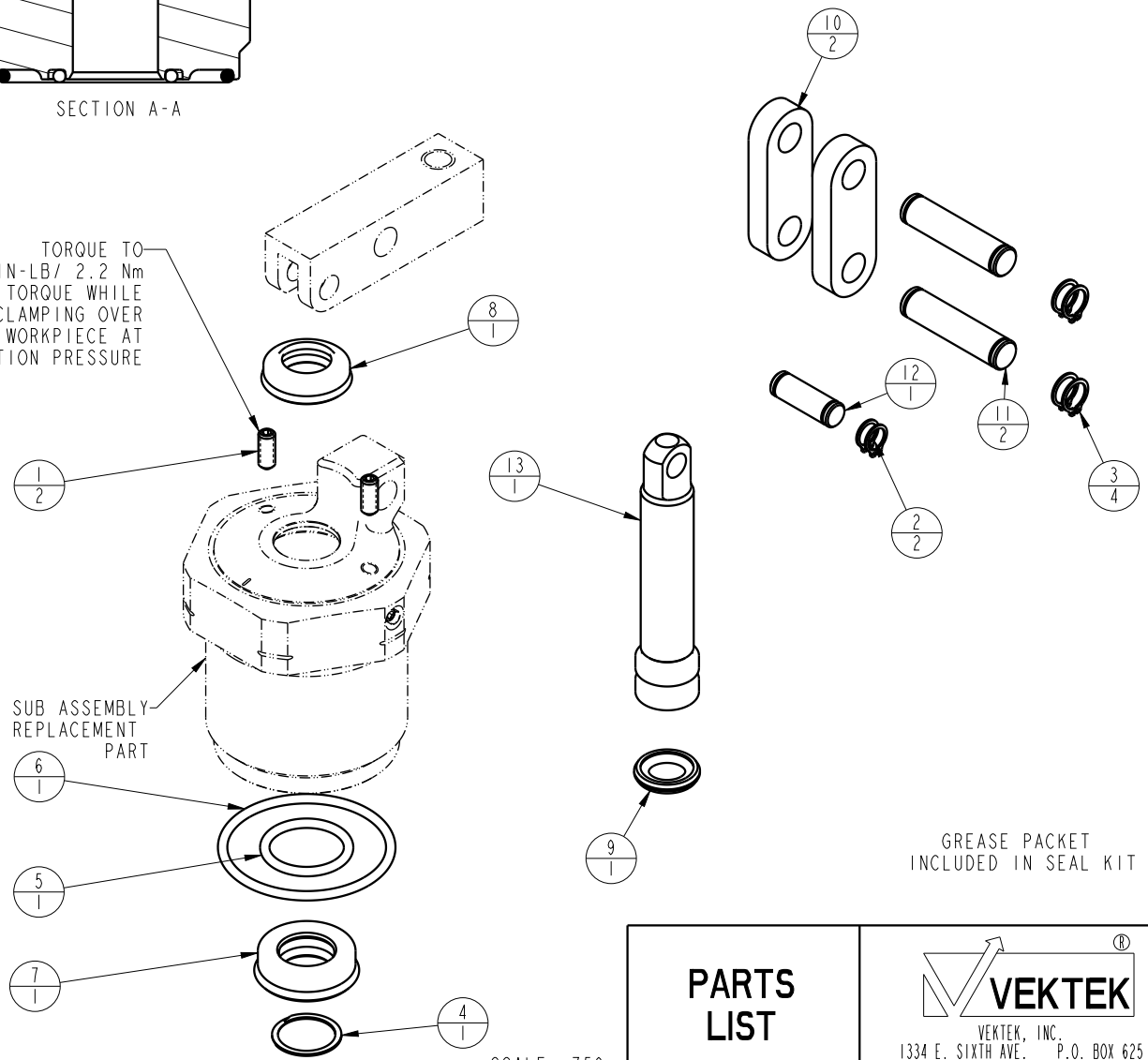

NO	QTY	PART NO	DESCRIPTION	STD SEAL KIT
1	2	21440042	SHSS, CUP POINT, 5-40 X 5/16	
2	2	23050031	RING, RTNG, EXT, 0.197	X
3	4	23050032	RING, RTNG, EXT, 0.236	X
4	1	23050049	RETAINING RING, SPIRAL, INTL	X
5	1	39050037	O-RING, (-015)	X
6	1	39051125	O-RING, (-025)	X
7	1	39052058	SEAL, ROD, RSD, 10, 85A, AU	X
8	1	39053039	SEAL, WIPER, SNAP IN, WED, 10, 94A, AU	X
9	1	39056030	SEAL, CAP, PISTON, 12, 94A, AU	X
10	2	81600145	LINK, LC, 7MPa, 25B	
11	2	81600150	PIN, LINK, LC, 7MPa, 25B	
12	1	81600155	PIN, PLUNGER, LC, 7MPa, 25B	
13	1	81600250	PLUNGER, LC, TL360, DA, 600/2.73kN	
N/A	N/A	60160216	KIT, SEAL, LC, TL360, DA, 2.73kN	NOTED

TORQUE TO
20 IN-LB/ 2.2 Nm
TORQUE WHILE
CLAMPING OVER
WORKPIECE AT
OPERATION PRESSURE

BODY SUB ASSEMBLY
NOT A REPLACEMENT
PART



GREASE PACKET
INCLUDED IN SEAL KIT

PARTS LIST	 VEKTEK, INC. 1334 E. SIXTH AVE. P.O. BOX 625 EMPORIA, KS. 66801 U.S.A.
	PARTS LIST, ASSY, LC, CM, TL360, DA, 2.73kN ROTARY LUG SIZE A MPL1635 REV A

A	5122	RELEASE	BDC	6/11/24
REV	IN ACCORDANCE WITH ECN	EFFECTIVE DATE	REVISED BY	DATE
DRW BY:	BDC	DRAWING STATUS: Released PRODUCTION APPROVED FOR RELEASED STATUS ONLY		
DATE:	6/28/23			