

**THIS IS A TWO PAGE PARTS LIST.
THIS FIRST PAGE APPLIES TO
MODEL No. 21010808 AT REVISION R AND LATER REVISIONS**

NO	QTY	PART NO	DESCRIPTION	STD SEAL KIT	FKM SEAL KIT	SPRING KIT
1	1	23050009	WASHER	X	X	X
2	1	23350073	SPRING, COMPRESSION			X
3	1	39010013	SEAL, BEVEL, 9/16 X 3/32 X 3/4	X	39012000	
4	1	39012009	WIPER, PRESS-IN, (1/2)	X	X	
5	1	39055008	GASKET, COPPER	X	X	X
6	1	82010810	PISTON, CYL, CM, 2200, .75 STRK			
7	1	39T55005	GASKET, (.753x.080x.080)	X	X	X
N/A	N/A	60210108	KIT, SEAL, CYL, CM, 2200, SA	NOTED	N/A	N/A
N/A	N/A	6V210108	KIT, SEAL, CYL, CM, 2200, SA, FKM	N/A	NOTED	N/A
N/A	N/A	61210317	KIT, SPRING, CYL, CM, 2200, .75STRK	N/A	N/A	NOTED

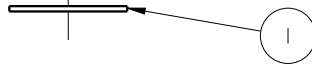
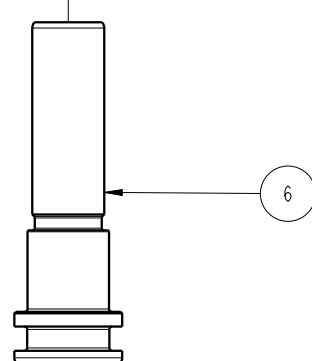
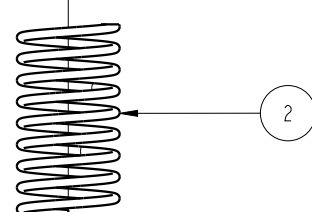
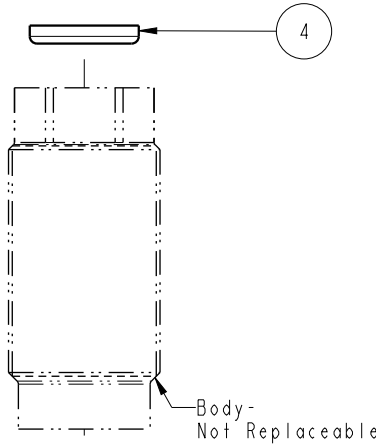

See IS-2100 for machining and installation instructions. Lubricate all seals with clean hydraulic oil prior to assembly. **DO NOT USE SILICONE BASED LUBRICANTS.**

INSTALLATION TORQUE:
 -Metal Gasket = 50 ft-lb
 -Composite Gasket = 25 ft-lb
 *Cylinders may need to be re-torqued after a break-in period of 3 weeks or 2,500 cycles for both gasket styles.

Both metal and composite gaskets are supplied. Use only one gasket. The metal gasket is recommended when the cavity seal surface has every smooth finish and is flat and perpendicular to the minor diameter. The metal gasket must be torqued to a higher value, which is more resilient to machining vibrations providing long term sealing. The composite gasket is recommended when the cavity seal surface has a rough surface finish or is not flat.

PARTS LIST	 VEKTEK, INC. 1334 E. SIXTH AVE. P.O. BOX 625 EMPORIA, KS. 66801 U.S.A.	
	ASSEMBLIES AFFECTED 21-0108-08 21-0108-08F	
	PARTS LIST, ASSY, CYL, CM, 2200, .75 STRK, THD SIZE A PL2104	REV P

P	3140	RELEASE	BCD	11/9/16
REV	IN ACCORDANCE WITH ECN	EFFECTIVE DATE	REVISED BY	DATE
DRW BY:	JACOB	DRAWING STATUS: Released PRODUCTION APPROVED FOR RELEASED STATUS ONLY		
DATE:	08-07-90			

SHEET 1 OF 2

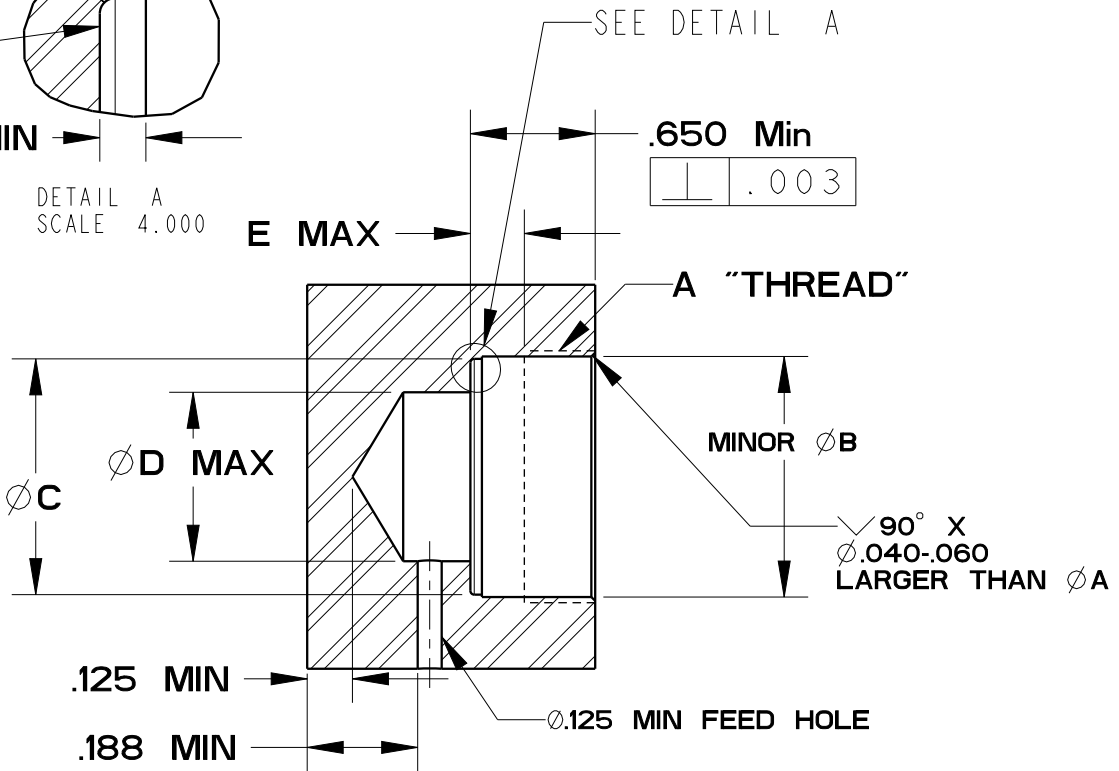
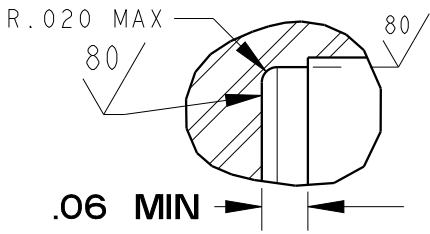

Tighten cylinders with a six point socket only !

Model No.	A	Metal Gasket Torque	Composite Gasket Torque	ØB	ØC	D	E
21-0102-00	3/8-24 UNF-2B	10 ft lb	NA	.335±.003	.325±.005	.13	.100
21-0104-02	5/8-18 UNF-2B	30 ft lb	15 ft lb	.572±.003	.545±.005	.31	.156
21-0105-03	3/4-16 UNF-2B	40 ft lb	20 ft lb	.690±.003	.662±.005	.38	.156
21-0105-04	3/4-16 UNF-2B	40 ft lb	20 ft lb	.690±.003	.662±.005	.38	.156
21-0105-05	3/4-16 UNF-2B	40 ft lb	20 ft lb	.690±.003	.662±.005	.38	.156
21-0105-06	3/4-16 UNF-2B	40 ft lb	20 ft lb	.690±.003	.662±.005	.38	.156
21-0108-04	1 1/16-16 UN-2B	50 ft lb	25 ft lb	1.002±.003	.923±.005	.63	.281
21-0108-05	1 1/16-16 UN-2B	50 ft lb	25 ft lb	1.002±.003	.923±.005	.63	.281
21-0108-08	1 1/16-16 UN-2B	50 ft lb	25 ft lb	1.002±.003	.923±.005	.63	.281
21-0110-04	1 5/16-16 UN-2B	NA	35 ft lb	1.253±.003	1.228±.005	.88	.281

*Cylinders may need to be re-torqued after a break-in period of 3 weeks or 2,500 cycles for both gasket styles.

Instruction Sheet



VEKTEK, INC.
1334 E. SIXTH AVE. P.O. BOX 625
EMPORIA, KS. 66801 U.S.A.

Model number -See Chart-

Cavity Dimensions

Cartridge Mounted Cylinders

SIZE A **IS-2100** REV G

FORM FEG041-IS-ASIZE, REV. B

G	3041	RELEASE	BCD	11/9/16
REV	IN ACCORDANCE WITH ECN	EFFECTIVE DATE	REVISED BY	DATE
DRW BY:	VANDALSEM			
DATE:	04-13-93			
DRAWING STATUS: Released PRODUCTION APPROVED FOR RELEASED STATUS ONLY				