

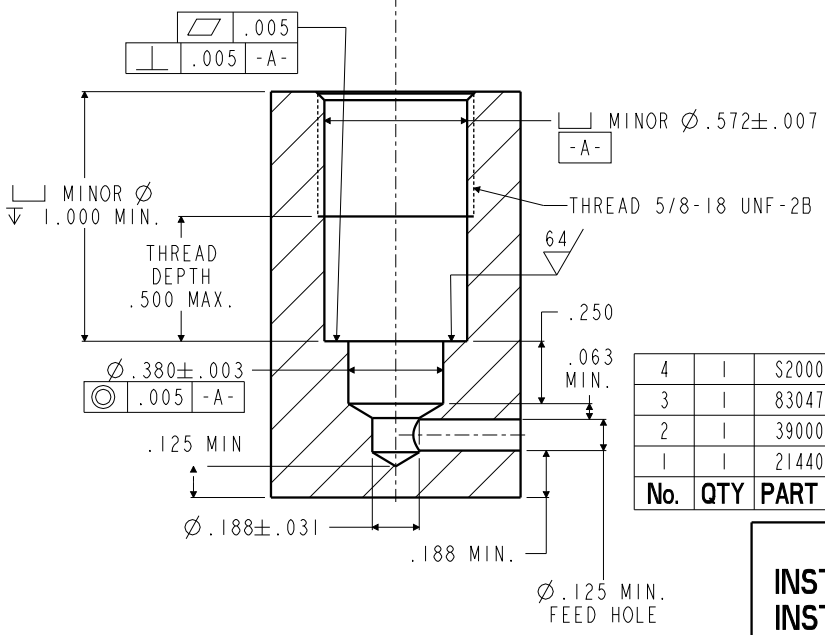

COMPONENTS FROM 62300004 MANIFOLD MOUNTING KIT ASSEMBLE I.A.W. INSTRUCTIONS BELOW

1. THREAD SET SCREW INTO CYLINDER FOR DEPTH SHOWN ABOVE. LOCTITE IN POSITION.
2. PRESS SUPPORT INTO CAVITY COUNTERBORE.
3. LUBRICATE O-RING AND STRETCH OVER SUPPORT.

LUBRICATE ALL SEALS WITH CLEAN HYDRAULIC OIL PRIOR TO ASSEMBLY. DO NOT USE SILICONE BASED LUBRICANTS.



No.	QTY	PART No.	DESCRIPTION
4	1	S2000400	ASSY, CYL, TB, SA, 550, W/O SPRING
3	1	83047904	SUPPORT, 3/8 O.D. X 3/16 I.D. X 3/8 LG
2	1	39000070	O-RING, (-904)
1	1	21440010	SHSS, HOLLOW

<b>INSTALLATION INSTRUCTIONS</b>	 <b>VEKTEK</b> VEKTEK, INC. 1334 E. SIXTH AVE. P.O. BOX 625 EMPORIA, KS. 66801 U.S.A.
	ASSEMBLIES AFFECTED S2000400
MANIFOLD MOUNTING OF S2000400 CYLINDER	SIZE A <b>IS2001</b>

D	4312	RELEASE	JDW	01/28/94
REV	IN ACCORDANCE WITH ECN	EFFECTIVE DATE	REVISED BY	DATE
DRW BY:	VANDALSEM	<b>DRAWING STATUS: Released</b>		
DATE:	01/28/94	PRODUCTION APPROVED FOR RELEASED STATUS ONLY		