

Vekttek, Inc. 1334 East Sixth Ave. P.O. Box 625 Emporia, Ks. 66801 U.S.A.	Instruction Sheet	ISMV-	1006	
		REV:	A, I.A.W. ECN1423	
		BY/DATE:	M Say	01/09/06
		APPR/DATE:	K. Ratzlaff	2-16-06
Title Assembly/Disassembly: 33.4 & 55.6 kN Air Advance Work Supports				

Read all instructions before disassembly

Refer to the illustrations on page three for component part numbers and a tool list.

Disassembly

Notice: When disassembling multiple work supports, the plunger and body/sleeve assembly from each work support should be kept together.

1. Clamp the work support base (1) in a vise.
2. Connect a hydraulic power supply to the work support. Apply pressure (approximately 70 bar) to lock the plunger (3) in place.
3. Remove the threaded plug (9) inside the plunger.
4. Release the hydraulic pressure and disconnect the line.
5. Loosen the spring stud (4), allowing the plunger (3) to rise up, as the spring stud is unthreaded from the base (1).
6. Unthread the body/sleeve assembly (2) from the base (1) and remove the body/sleeve assembly (2) and plunger (3) together from the base. **Caution: Do not allow the plunger to fall out of the body/sleeve assembly during removal. Use a six-point socket only. Other types of wrenches may damage the work support.**
7. Slide the plunger (3) out of the body/sleeve assembly (2).
8. Remove the retaining ring (11) from the plunger. Slide the washer (10), spring (5) and spring stud (4) out of the plunger.
9. Remove the wiper (8) from the body/sleeve assembly. **Caution: Do not scratch the inner sleeve.**
10. Remove the o-rings (6)(7) from the body/sleeve assembly.
11. Clean all parts thoroughly and set aside to dry.

Vekttek, Inc. 1334 East Sixth Ave. P.O. Box 625 Emporia, Ks. 66801 U.S.A.	Instruction Sheet	ISMV-	1006		
		REV:	A, I.A.W. ECN1423		
		BY/DATE:	M Say	01/09/06	
		APPR/DATE:	K. Ratzlaff	2-16-06	
Title Assembly/Disassembly: 33.4 & 55.6 kN Air Advance Work Supports					

Assembly

1. Lubricate all O-rings with clean hydraulic fluid. See the Vekttek catalog for hydraulic oil specifications and recommendations.
2. Press the wiper (8) into the counterbore of the body/sleeve/assembly (2).
3. Insert the spring stud (4), spring (5) and washer (10) into the plunger (3).
4. Install the retaining ring (11).
5. Insert the plunger (3) into the body/sleeve assembly (2) from the bottom.
6. Place the O-rings (6)(7) in the base as shown on page three.
7. Hold the body/sleeve assembly and plunger together and insert them in to the base. Thread the body/sleeve assembly (2) to a hand tight position. **Note: Make certain that the O-rings (6)(7) have not moved out of position.**
8. Tighten the spring stud (9) to the base (1).
9. Tighten the body/sleeve assembly (2) to the base according to the torque specification on the parts list. **Caution- Use a six-point socket only. Other types of wrenches may damage the work support.**
10. Connect a hydraulic power supply to the work support. Apply hydraulic pressure (approximately 70 bar psi) to lock the plunger (3) in place.
11. Install the plug (9) into the threaded hole in the plunger and tighten to the specification on the parts list.
12. Release the pressure and disconnect the hydraulic line.

Vektek, Inc. 1334 East Sixth Ave. P.O. Box 625 Emporia, Ks. 66801 U.S.A.	Instruction Sheet		ISMV-	1006
			REV:	A, I.A.W. ECN1423
			BY/DATE:	M Say 01/09/06
			APPR/DATE:	K. Ratzlaff 2-16-06
Title Assembly/Disassembly: 33.4 & 55.6 kN Air Advance Work Supports				

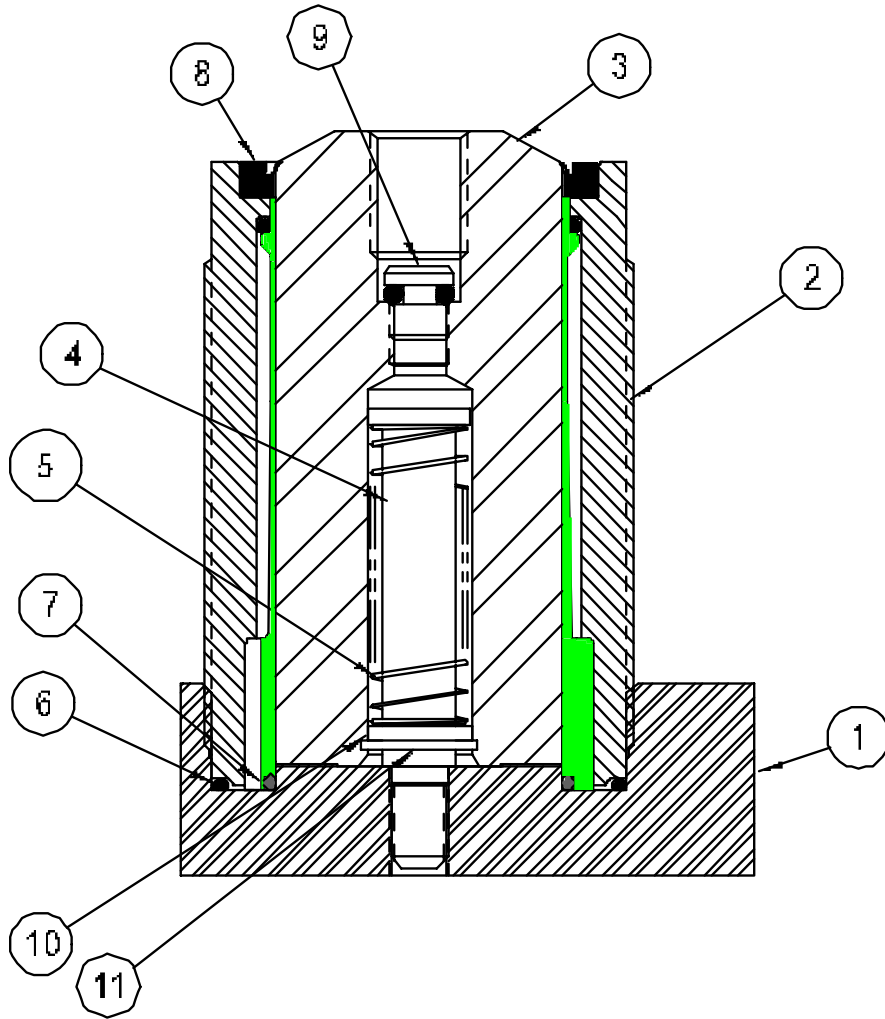

Model Number	Tools needed
41-0060-02	50 mm socket, 1/8 & 3/16 hex key
41-0060-03	70 mm socket, 1/8 & 3/16 hex key