

Vekttek, Inc. 1334 East Sixth Ave. P.O. Box 625 Emporia, Ks. 66801 U.S.A.	<b>Instruction Sheet</b>	IS	1004		
		REV.	B I.A.W. ECN 1990		
		BY/DATE:	JDW	1-14-09	
		APPR/DATE:	JAM	1-30-09	
<b>Title: Disassembly/Assembly: 1000 &amp; 2500 Spring Advance Work Supports</b>					

**Read all instructions before disassembly**

**Refer to the illustrations on page three for component part numbers and a tool list.**

## Disassembly

**Notice: When disassembling multiple work supports, the plunger and body/sleeve assembly from each work support should be kept together.**

1. Clamp work support base (1) in a vise. Cartridge mounted work supports must remain in their fixture for steps two and three.
2. Connect a hydraulic power supply to the work support. Apply pressure (approximately 1000 psi) to lock the plunger (2) in place.
3. Remove the set screw (3) inside the tapped hole of the plunger.
4. Release the pressure and disconnect the hydraulic line.
5. Remove the work support cartridge from the base (1) or the fixture cavity.  
**Caution- Use a six-point socket only. Other types of wrenches may damage the work support.**
6. Unscrew the threaded retainer (6) from the work support and slide it and the plunger (2) out of the body/sleeve assembly (5).
7. Remove the O-ring (11) and gasket (8). Remove metal back-up ring (12) from the base(1).  
**Note for 2500 work support only: If new seals were purchased after 3-20-2009 and are being installed the gasket has changed and the metal back-up ring should not be reinstalled.**
8. Remove the retainer from the plunger by pushing the retainer away from its seat, tipping it to one side, and to allowing it to slip out of the retainer cavity. **Note: Work supports produced prior to December 1, 1998 will disassemble without repositioning the retainer. On those models, remove it, by unthreading it from the body/sleeve assembly and pulling it directly out of the plunger.**
9. Remove the wiper (9) from the body. **Caution--Do not scratch the inner sleeve.**
10. Clean all parts thoroughly and set aside to dry.

Vekttek, Inc. 1334 East Sixth Ave. P.O. Box 625 Emporia, Ks. 66801 U.S.A.	<b>Instruction Sheet</b>	IS	1004		
		REV.	B I.A.W. ECN 1990		
		BY/DATE:	JDW	1-14-09	
		APPR/DATE:	JAM	1-30-09	
<b>Title: Disassembly/Assembly: 1000 &amp; 2500 Spring Advance Work Supports</b>					

## Assembly

1. Lubricate all seals and wipers with clean hydraulic oil (Vekttek 65-0010-01 or equivalent). Apply Loctite primer N® or equivalent to the retainer (6) and the set screw (3) and set aside to dry.
2. Insert the piston (10) into the plunger making certain that it seats against the bottom of the bore in the plunger.
3. Insert the spring (7) into the plunger (2) bore.
4. Insert the retainer (6) into the plunger by tipping it to one side and slipping it through the smaller hole, allowing it to seat squarely on the opposite side of the hole. **Note: The retainer should move smoothly up and down within the hole, when enough force is used to overcome the spring pressure.**
5. Apply Loctite 243® or equivalent to the retainer (6) threads and tighten it to the torque specification on the parts list.
6. Place the o-ring (11) on the bottom of the retainer (6) and the gasket (8) on the body/sleeve assembly (5).
7. Place the metal backup ring (12) into the base/fixture cavity. **Note for 2500 work support only: If installing new seals purchased after 3-20-2009 the metal back-up ring should not be reinstalled.** Screw the body/sleeve assembly (5) into the base/fixture. The assembly will come to a positive stop when it contacts the mating surface. Do not tighten it until it has been determined that the backup ring (12) is in place and that the assembly is in contact with the mating surface.
8. Tighten the body/sleeve assembly (5) to the torque specification on the parts list. **Caution- Use a six-point socket only. Other types of wrenches may deform the wiper counterbore.**
9. Connect the hydraulic power supply to the work support. Apply pressure (approximately 1000 psi) to lock the plunger (2) in place.
10. Apply one drop of Loctite 243® or equivalent to the threads of the set screw (3) and tighten it to the specification on the parts list.

<b>Vekttek, Inc.</b> 1334 East Sixth Ave. P.O. Box 625 Emporia, Ks. 66801 U.S.A.	<b>Instruction Sheet</b>	IS	1004		
		REV.	B I.A.W. ECN 1990		
		BY/DATE:	JDW	1-14-09	
		APPR/DATE:	JAM	1-30-09	
<b>Title: Disassembly/Assembly: 1000 &amp; 2500 Spring Advance Work Supports</b>					

11. Release the pressure and disconnect the hydraulic line.

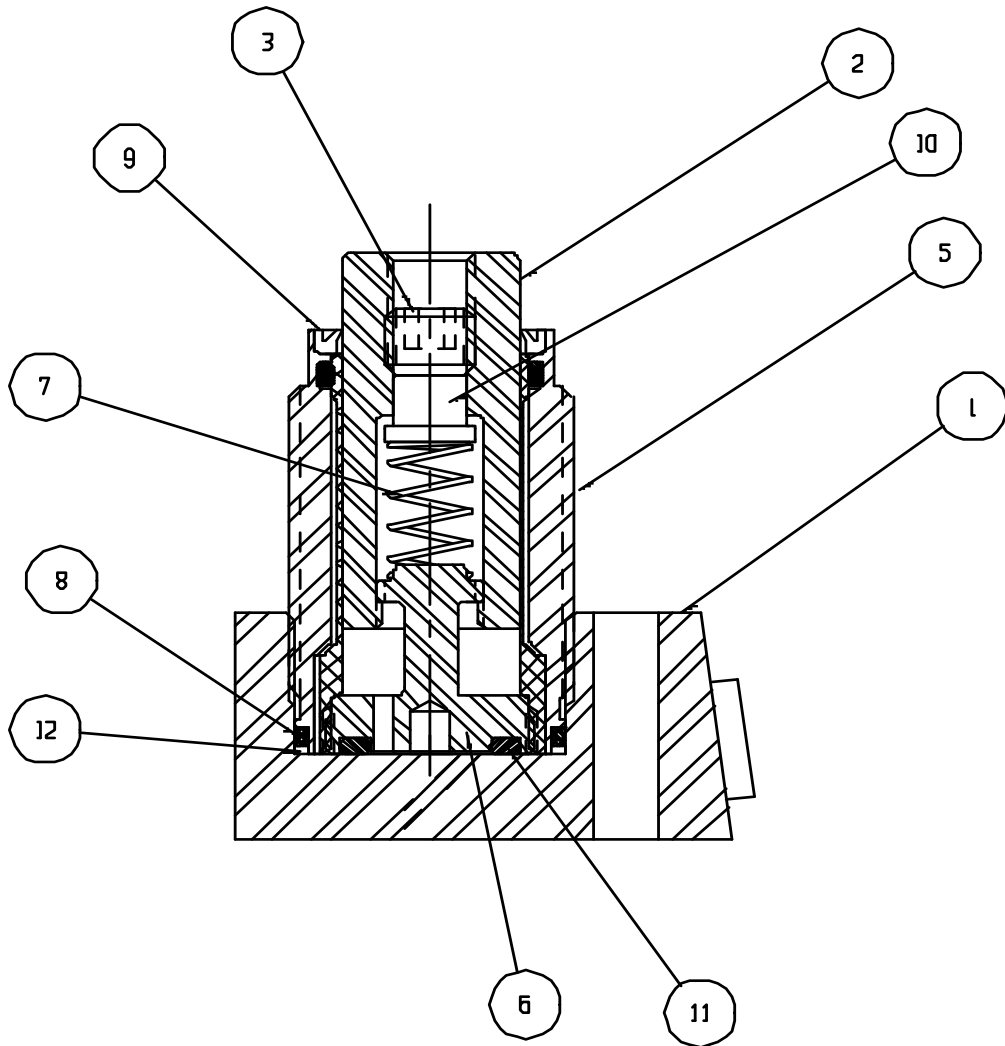

Model Number	Tool List
10050606	5/32 hex key, spanner wrench, 7/8 socket (6 pt)
10050607	5/32 hex key, spanner wrench, 7/8 socket (6 pt)
10050608	5/32 hex key, spanner wrench, 7/8 socket (6 pt)
10050903	3/16 hex key, spanner wrench, 1-1/8 socket (6 pt)
10050904	3/16 hex key, spanner wrench, 1-1/8 socket (6 pt)
10050905	3/16 hex key, spanner wrench, 1-1/8 socket (6 pt)