

MOUNTING HOLES
5/16-18 UNC
FOR SHCS ∇ .5 MIN

OUTLINE OF PALLET RECEIVER
(TOP SIDE)

BACK MOUNT

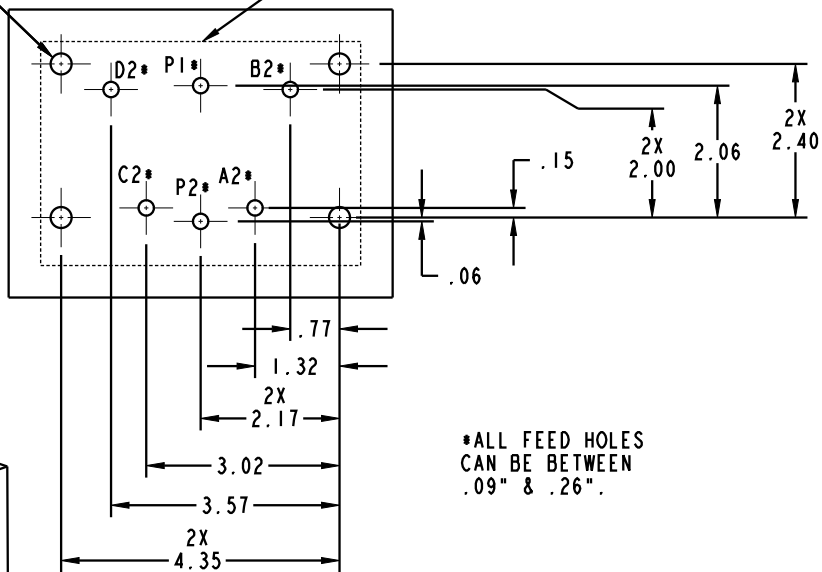

*ALL FEED HOLES
CAN BE BETWEEN
.09" & .26"

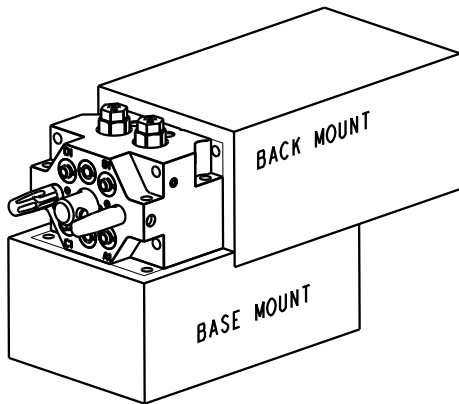

BASE MOUNT

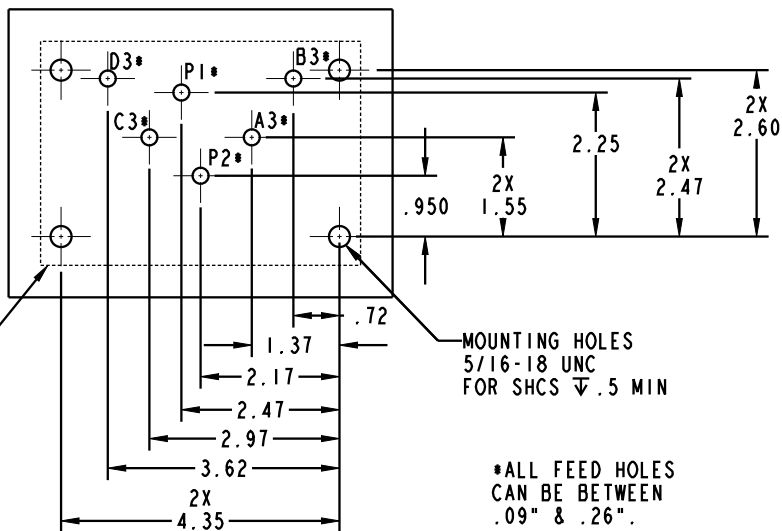

MOUNTING HOLES
5/16-18 UNC
FOR SHCS ∇ .5 MIN

*ALL FEED HOLES
CAN BE BETWEEN
.09" & .26"

OUTLINE OF PALLET RECEIVER
(FRONT SIDE)

###TORQUE 5/16 -18 MOUNTING SOCKET HEAD
CAP SCREWS TO A MINIMUM OF 20 FT*LBS
AND A MAXIMUM OF 35FT*LBS

**INSTALLATION
INSTRUCTIONS**



VEKTEK, INC.
1334 E. SIXTH AVE. P.O. BOX 625
EMPORIA, KS. 66801 U.S.A.

ASSEMBLIES AFFECTED
56-0010-00 56-0010-12
56-0010-10
56-0010-11

IS, PALLET RECEIVER MOUNTING & AUTO COUPLER SCHEMATICS

SIZE
A IS5650

REV
C

C	5757	RELEASE	BDC	7/17/25
REV	IN ACCORDANCE WITH ECN	EFFECTIVE DATE	REVISED BY	DATE
DRW BY:	BDC	DRAWING STATUS: Design		
DATE:	7/19/23	PRODUCTION APPROVED FOR RELEASED STATUS ONLY		

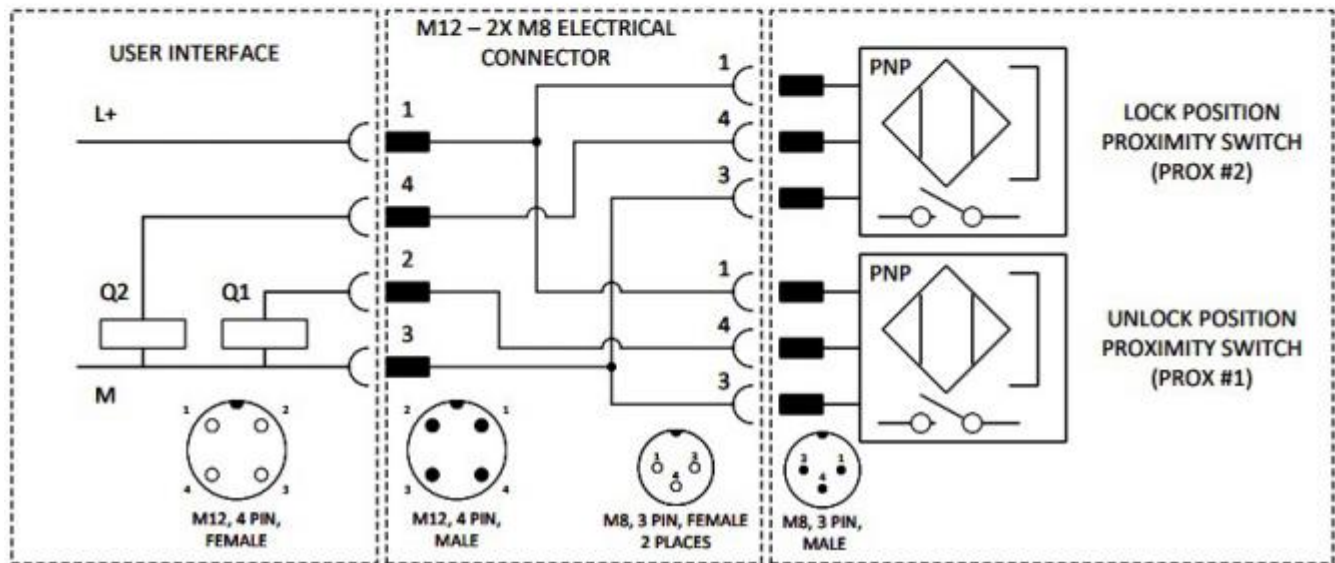
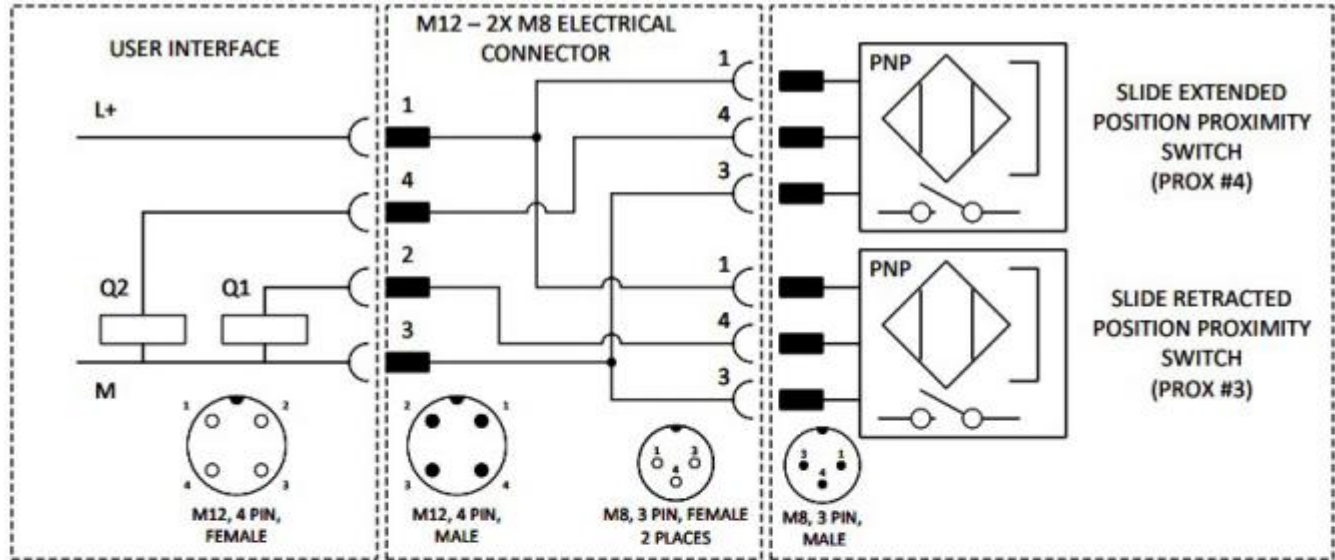

INSTALLATION INSTRUCTIONS		 VEKTEK, INC. 1334 E. SIXTH AVE. P.O. BOX 625 EMPORIA, KS. 66801 U.S.A.	
ASSEMBLIES AFFECTED 56-0010-00 56-0010-12 56-0010-10 56-0010-11		IS, PALLET RECEIVER MOUNTING & AUTO COUPLER SCHEMATICS *****	
DATE: 7/19/23		SIZE A IS5650	
DRAWING STATUS: Released PRODUCTION APPROVED FOR RELEASED STATUS ONLY		REV C	

C	5757	RELEASE	BDC	7/17/25
REV	IN ACCORDANCE WITH ECN	EFFECTIVE DATE	REVISED BY	DATE



P3-0121-01

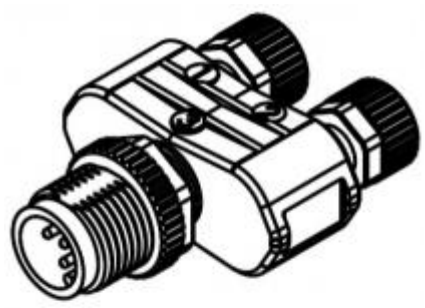
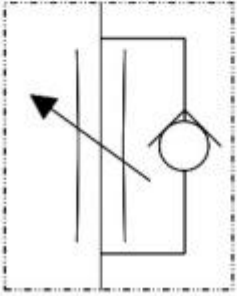

27-8422-03

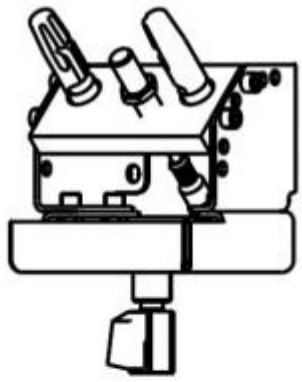
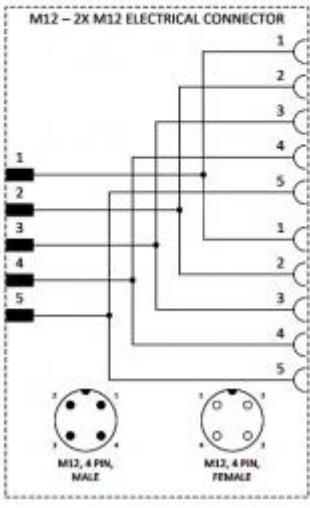

56-0008-20

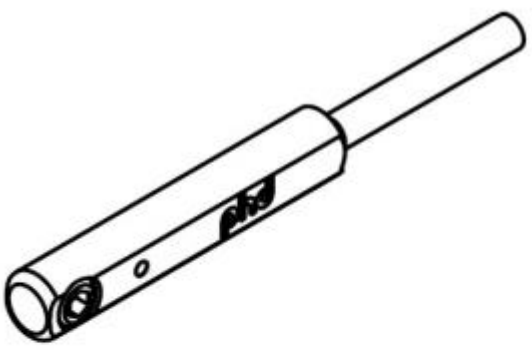
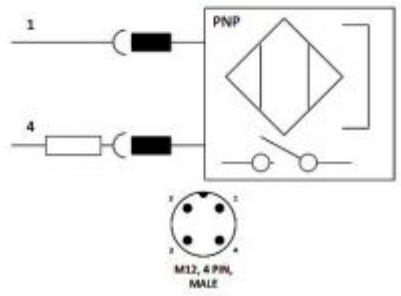

62-2970-02

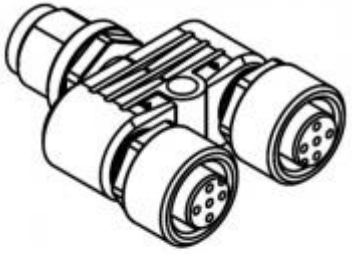
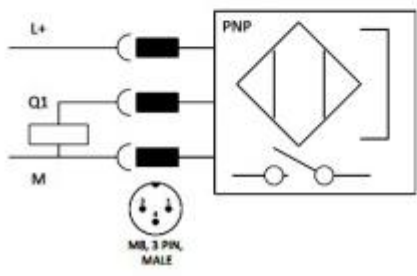

27-8422-02

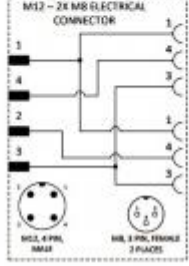

INSTALLATION INSTRUCTIONS



VEKTEK, INC.
1334 E. SIXTH AVE. P.O. BOX 625
EMPORIA, KS. 66801 U.S.A.

ASSEMBLIES AFFECTED
56-0010-00 56-0010-12
56-0010-10
56-0010-11

IS, PALLET RECEIVER MOUNTING & AUTO COUPLER SCHEMATICS

SIZE A 1S5650

REV C

C	5757	RELEASE	BDC	7/17/25
REV	IN ACCORDANCE WITH ECN	EFFECTIVE DATE	REVISED BY	DATE
DRW BY:	BDC	DRAWING STATUS: Released		
DATE:	7/19/23	PRODUCTION APPROVED FOR RELEASED STATUS ONLY		

MOUNT A' SLIDE

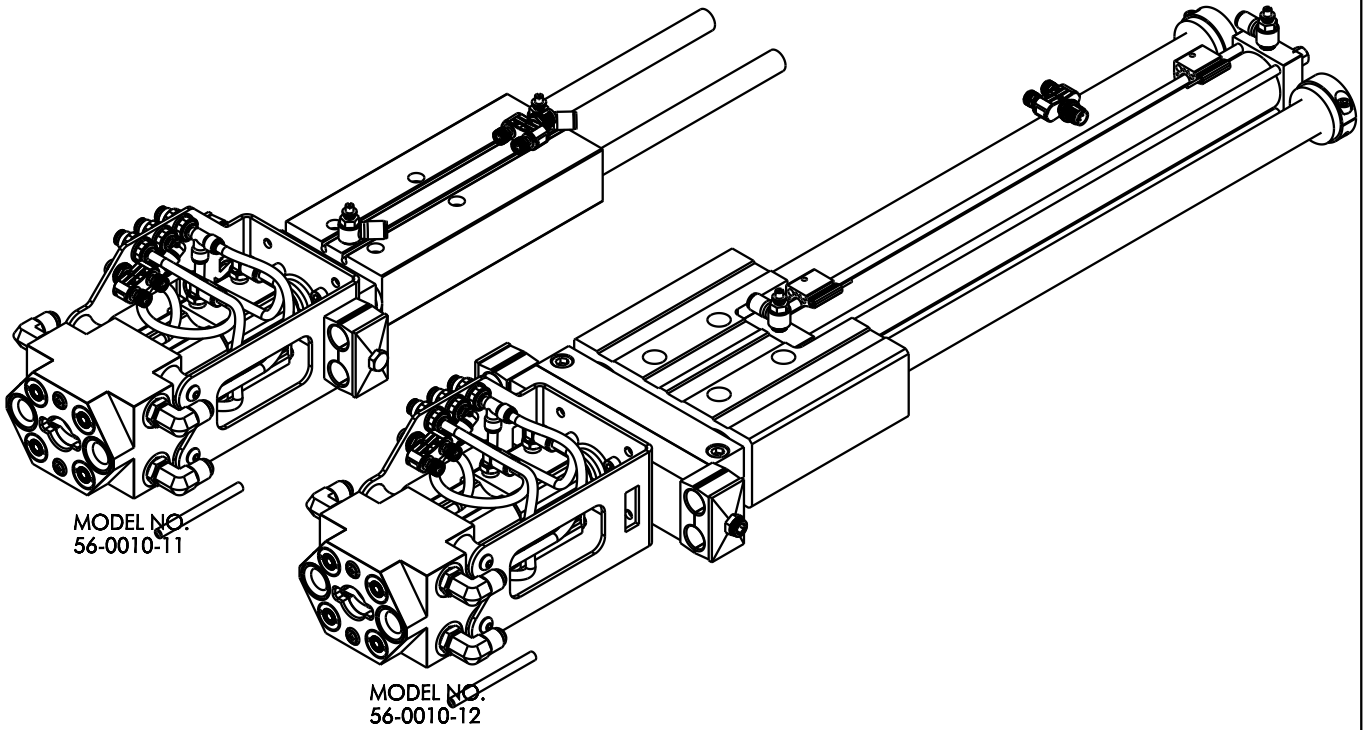

MODEL NO.
56-0010-11

MODEL NO.
56-0010-12

MOUNTING PATTERN FOR MODEL NO.56-0010-11

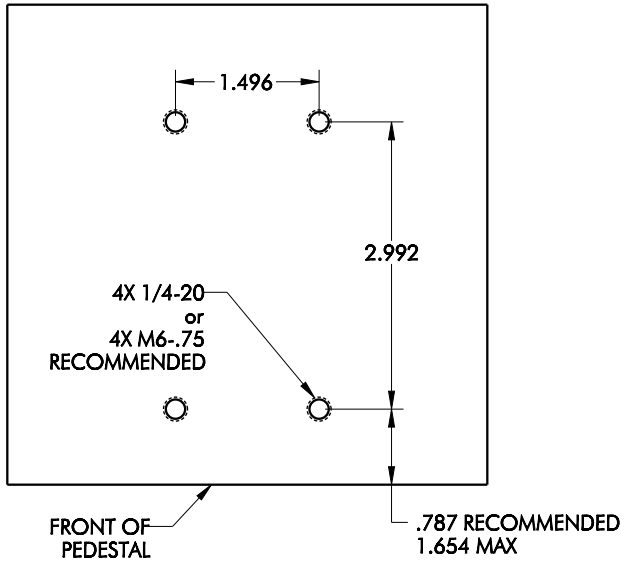

USE MINIMUM BOLT LENGTH OF 1.75" or 45mm.

MOUNTING PATTERN FOR MODEL NO.56-0010-12

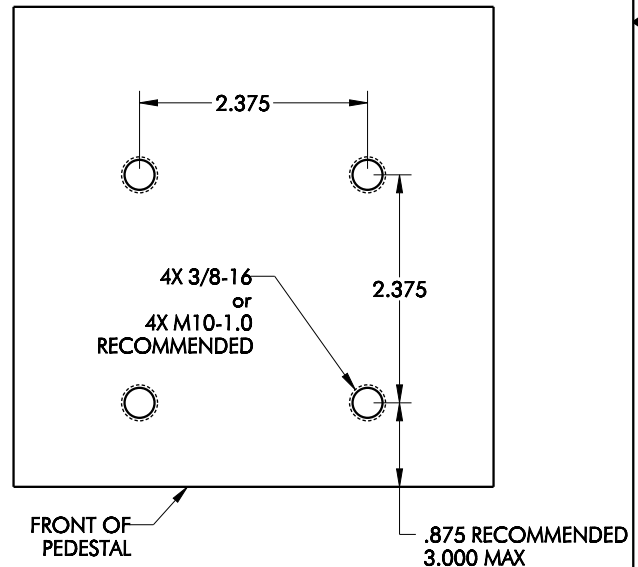

USE MINIMUM BOLT LENGTH OF 2.00" or 50mm.

INSTALLATION INSTRUCTIONS



VEKTEK, INC.
1334 E. SIXTH AVE. P.O. BOX 625
EMPORIA, KS. 66801 U.S.A.

ASSEMBLIES AFFECTED
56-0010-00 56-0010-12
56-0010-10
56-0010-11

IS, PALLET RECEIVER MOUNTING &
AUTO COUPLER SCHEMATICS

SIZE
A 1S5650

REV
C

C	5757	RELEASE	BDC	7/17/25
REV	IN ACCORDANCE WITH ECN	EFFECTIVE DATE	REVISED BY	DATE
DRW BY:	BDC	DRAWING STATUS: Released		
DATE:	7/19/23	PRODUCTION APPROVED FOR RELEASED STATUS ONLY		

SHEET 4 OF 4