

1

2

NOTE:  
FOR CAVITY TOOLING (MULTI-STEP REAMER AND M20 X 1.5 TAP), ORDER KIT 62-7040-00

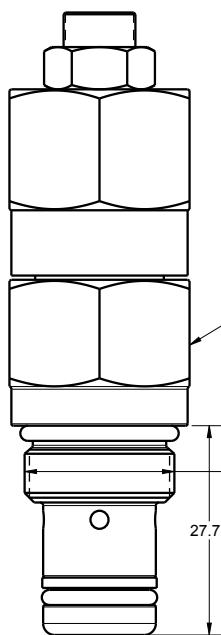

24 HEX TYPICAL  
TORQUE TO 48 Nm  
(35 FT-LB)

M20 x 1.5  
THREADS

27.7

SEQUENCE VALVE  
CARTRIDGE

SEQUENCE VALVE CARTRIDGE CAVITY DIMENSIONS FOR MACHINING WITH PORT TOOL

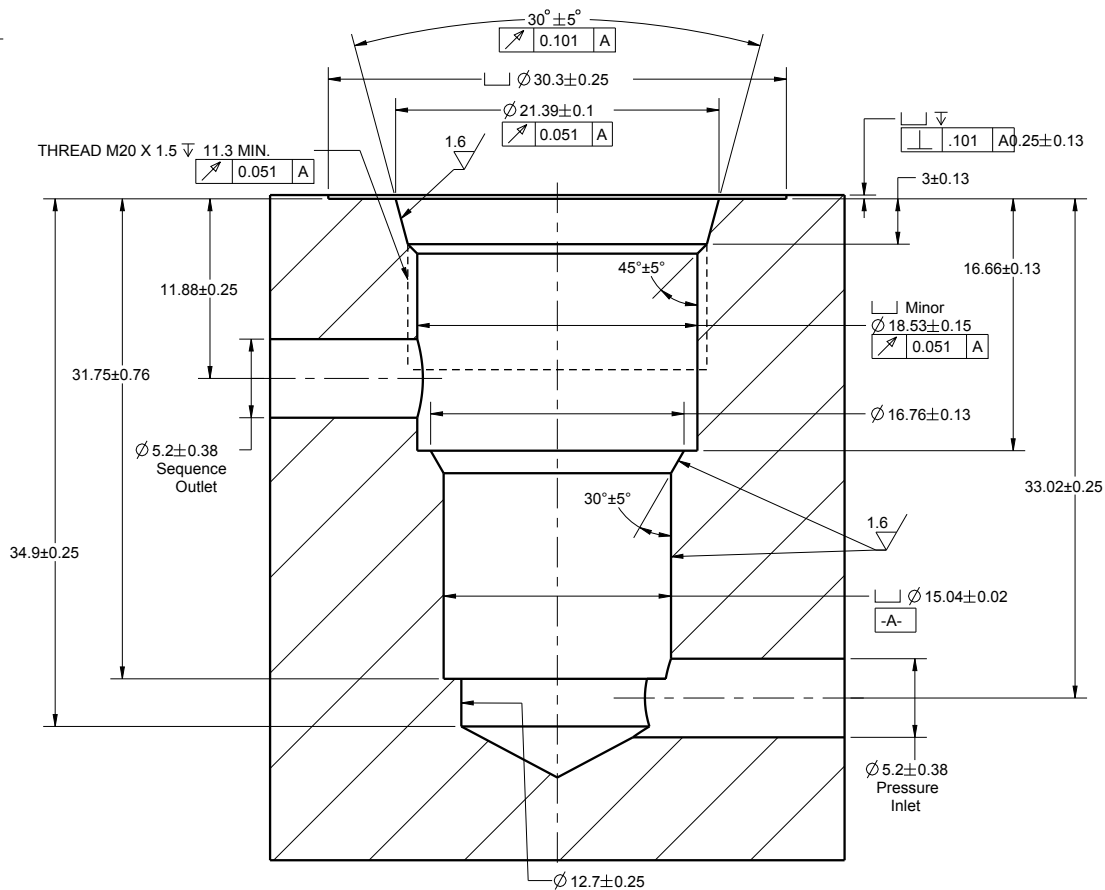

### INSTALLATION INSTRUCTIONS



VEKTEK, INC.  
1334 E. SIXTH AVE. P.O. BOX 625  
EMPORIA, KS. 66801 U.S.A.

VALVE, SEQUENCE, CAVITY, METRIC

ASSEMBLIES AFFECTED  
47-0400-00  
47-0400-01

SIZE  
A IS7003

REV  
D

D	3337	RELEASE	JDW	12/13/17
REV	IN ACCORDANCE WITH ECN	EFFECTIVE DATE	REVISED BY	DATE
DRW BY: ROMINE	DRAWING STATUS: <b>Released</b>			
DATE: 03/23/07	PRODUCTION APPROVED FOR RELEASED STATUS ONLY			

1

2

FORM FEG041\_IS\_SIZE, REV. B

SHEET 1 OF 1