

1
 ROTOR MUST BE IN THIS POSITION, RELATIVE TO THE PORTS, REGARDLESS OF HANDLE POSITION.

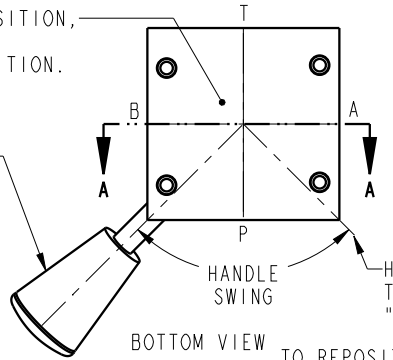

2
 FACTORY SET POSITION IN COUNTERCLOCKWISE DETENT

DO NOT MOVE! REPOSITIONING OF THE ROTOR WILL CAUSE THE ROTOR TO MALFUNCTION.

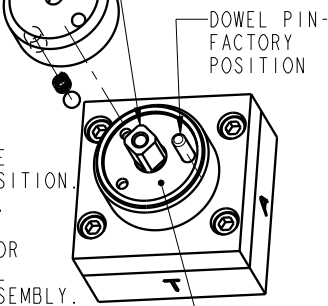

HANDLE THIS POSITION "P" TO "A"

HANDLE THIS POSITION "A" TO "T"

HANDLE - NOT REPLACEABLE

BONNET - NOT REPLACEABLE

BOTTOM VIEW

TO REPOSITION HANDLE:
 1. ROTATE HANDLE TO THE CLOCKWISE DETENT POSITION.
 2. REMOVE BONNET SCREW.
 3. SLIDE BONNET/HANDLE ASSEMBLY OFF OF ROTOR SHAFT - RETRIEVE BALL AND SPRING FOR REASSEMBLY.

4. PULL DOWEL PIN FROM BODY.
5. ROTATE DETENT PLATE (90° INCREMENTS) PLATE TO NEW POSITION.
6. INSERT DOWEL PIN THROUGH HOLE IN DETENT PLATE, PUSH GREASED SPRING INTO HOLE IN BONNET AND PLACE BALL ON CORRECT DETENT PLATE HOLE.
7. ALIGN BONNET/HANDLE ASSEMBLY WITH THE NEW POSITION OF THE DOWEL PIN AND SLIDE ONTO ROTOR SHAFT (SPRING AND BALL MUST BE IN PLACE)
8. REPLACE SCREW, VERIFY POSITION OF BONNET SEAL AND TIGHTEN BONNET SCREW.

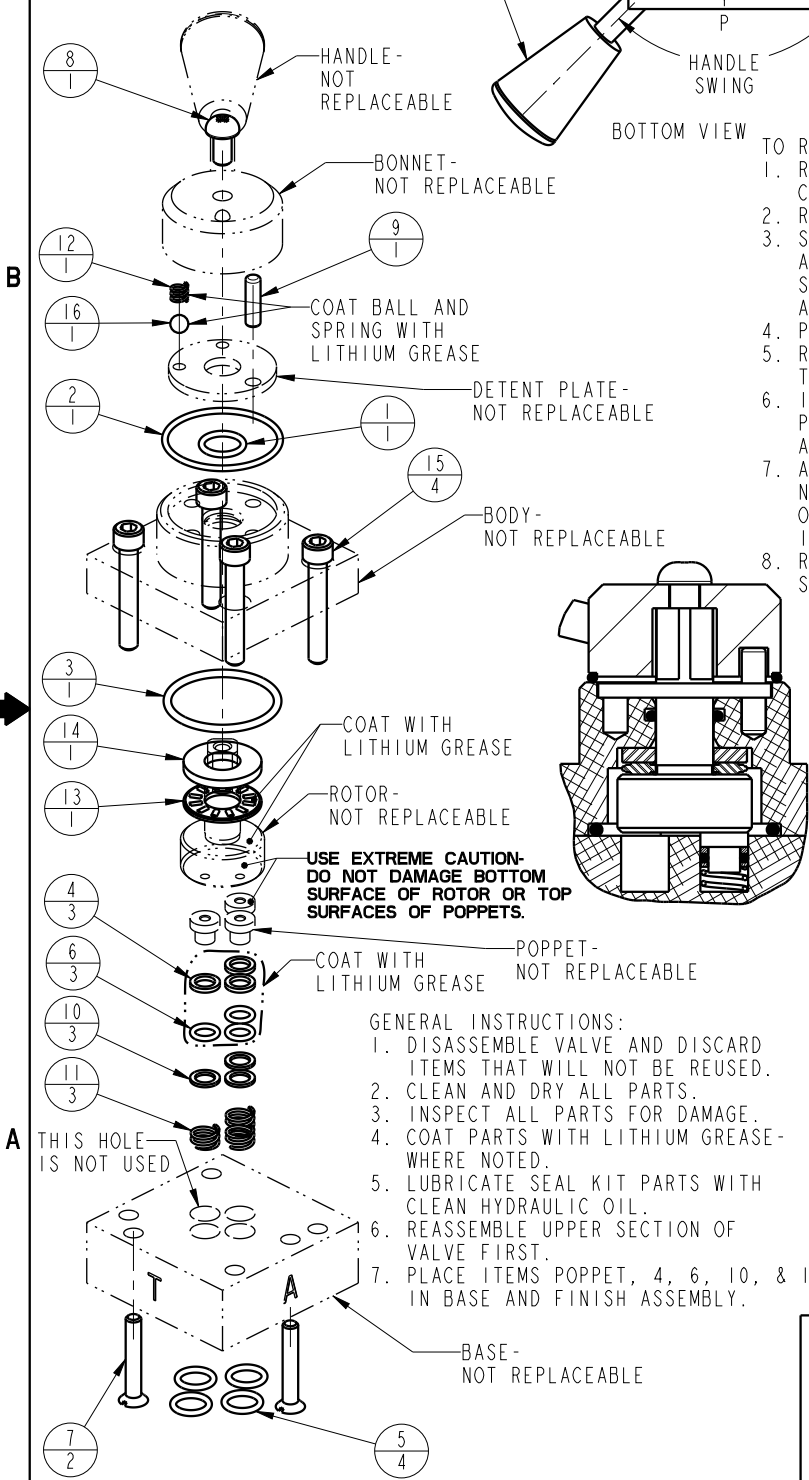

- GENERAL INSTRUCTIONS:
1. DISASSEMBLE VALVE AND DISCARD ITEMS THAT WILL NOT BE REUSED.
 2. CLEAN AND DRY ALL PARTS.
 3. INSPECT ALL PARTS FOR DAMAGE.
 4. COAT PARTS WITH LITHIUM GREASE - WHERE NOTED.
 5. LUBRICATE SEAL KIT PARTS WITH CLEAN HYDRAULIC OIL.
 6. REASSEMBLE UPPER SECTION OF VALVE FIRST.
 7. PLACE ITEMS POPPET, 4, 6, 10, & 11 IN BASE AND FINISH ASSEMBLY.

NO.	QTY	PART NO.	DESCRIPTION
16	1	23600011	BALL, STEEL, ALLOY, .187
15	4	21411027	SOCH, 10-24 X 1-1/4, ALY
14	1	87114008	WASHER, THRUST
13	1	87114009	BEARING, THRUST
12	1	23350139	SPRING, DETENT
11	3	23350138	SPRING, POPPET
10	3	21430049	WASHER, POPPET
9	1	90199984	PIN, DOWEL
8	1	21410047	SCREW, BONNET
7	2	21410107	SCREW, ASSEMBLY, VALVE
6	3	39000038	O-RING, POPPET
5	4	39050042	O-RING, MANIFOLD
4	3	39F54019	BACKUP RING, POPPET
3	1	39001024	O-RING, BODY
2	1	39001011	SEAL, BONNET
1	1	39002009	O-RING, SHAFT, ROTOR

INSTRUCTION SHEET -
 SEAL KIT
 INSTALLATION &
 HANDLE POSITIONING



VEKTEK, INC.
 1334 E. SIXTH AVE. P.O. BOX 625
 EMPORIA, KS. 66801 U.S.A.

Model Number
 71-1422-02

INSTRUCTION SHEET, 71-1422-02

VALVE, 3/2, D03, MANUAL

SIZE
 A

IS-7114

REV
 E

FORM FEG041-IS.AS.1Z, REV. B

E	3788	RELEASE	MJUST	7/30/19
REV	IN ACCORDANCE WITH ECN	EFFECTIVE DATE	REVISED BY	DATE
DRW BY:	MES	DRAWING STATUS: Released		
DATE:	07-26-10	PRODUCTION APPROVED FOR RELEASED STATUS ONLY		

SHEET 1 OF 1