

SCALE 0.500
 ILCP92205 REV E ECN5219

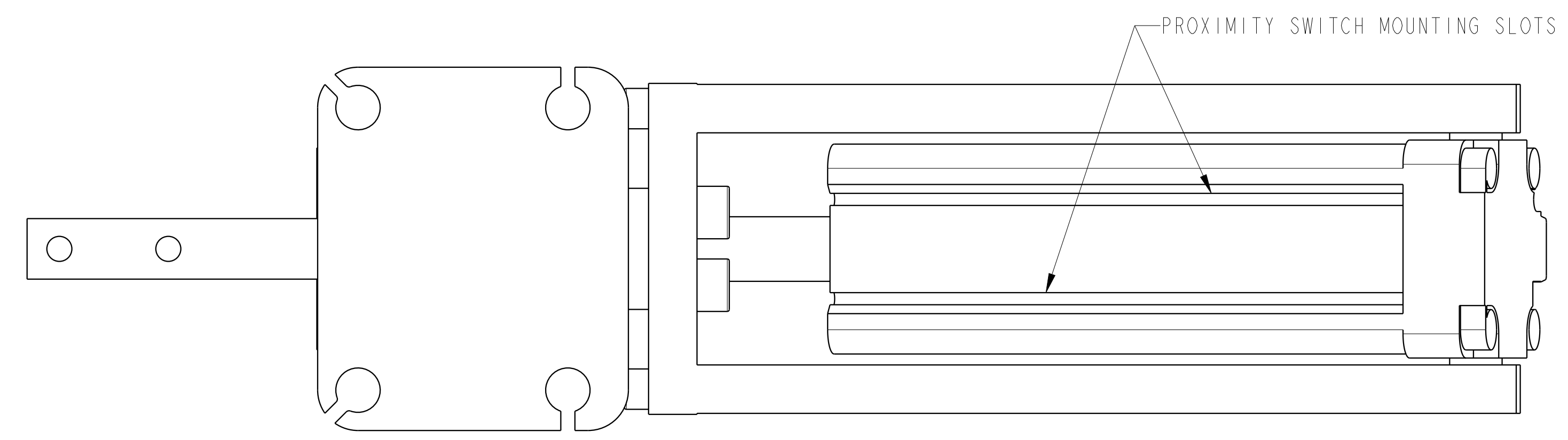
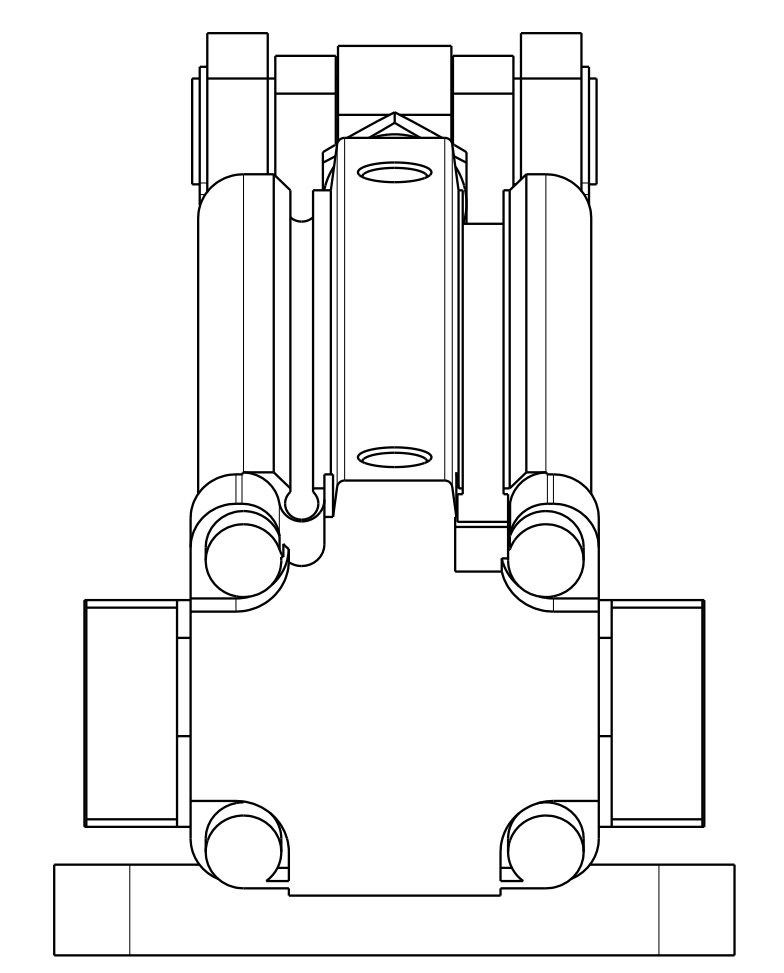
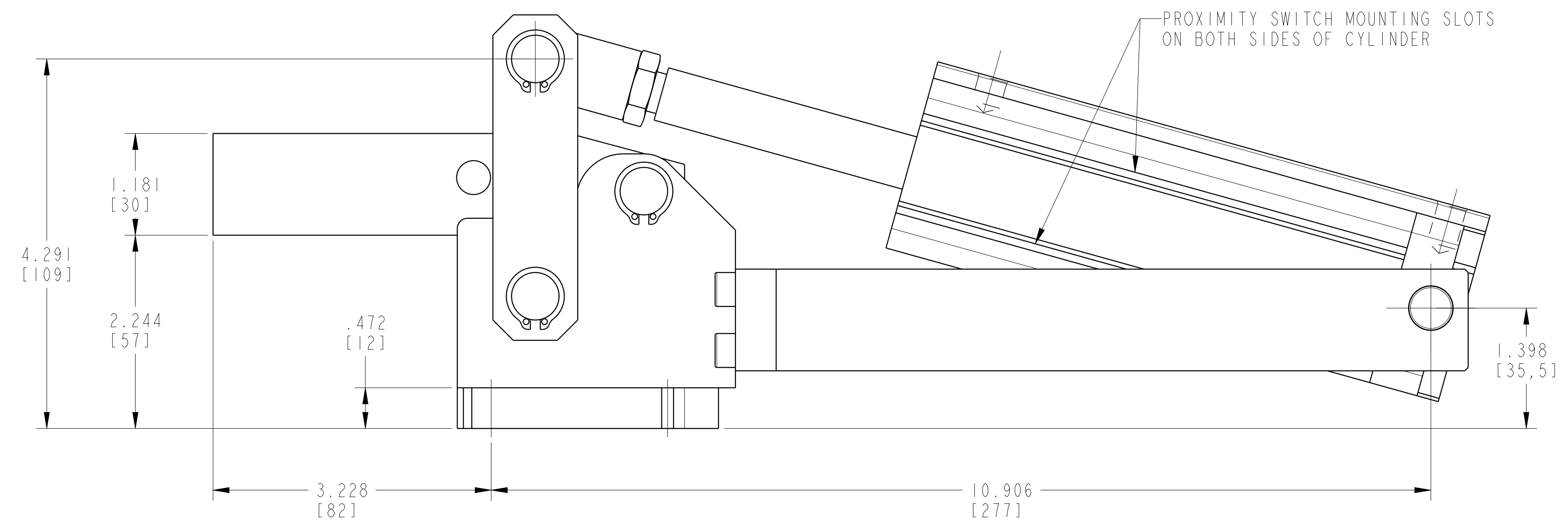
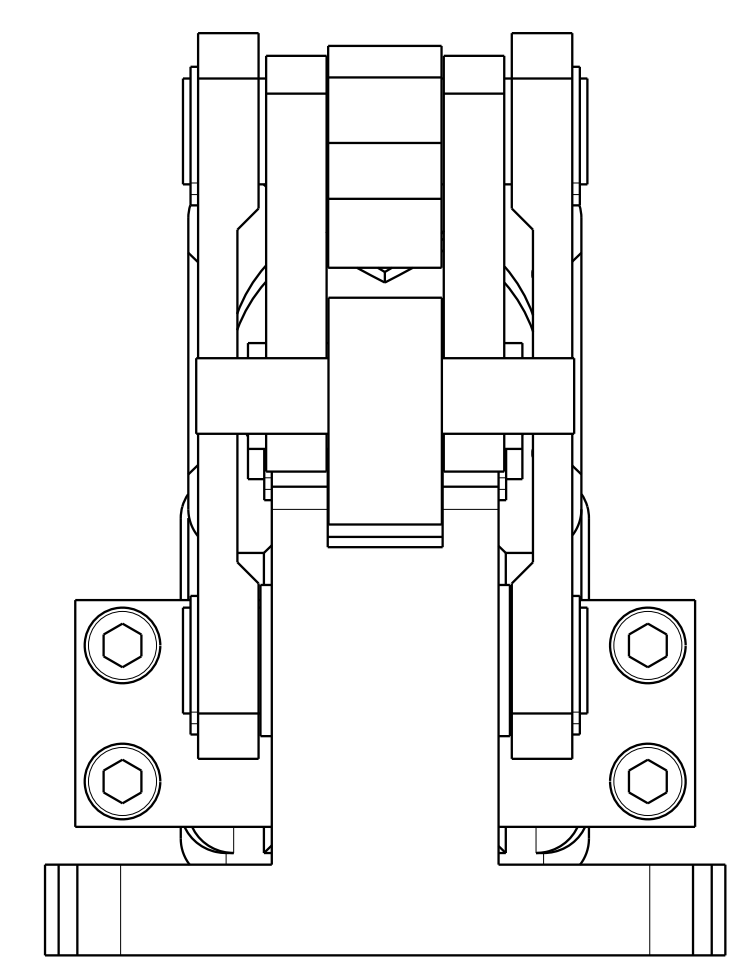

CAD CONTROL DRAWING		
	VEKTEK, INC. 1334 E. SIXTH AVE. P.O. BOX 625 EMPORIA, KS. 66801 U.S.A.	

E	5219	RELEASE	RLK	12/14/23
REV	IN ACCORDANCE WITH ECN	EFFECTIVE DATE	REVISED BY	DATE
DRW BY:	DRAWING STATUS: Released			
DATE:	PRODUCTION APPROVED FOR RELEASED STATUS ONLY			

P92205	B	CLAMP, TOGGLE, HD, HORZ, 4
REFERENCE MODEL	REF REV	
TOLERANCES DO NOT APPLY DIMENSIONS ARE NOMINAL		SIZE D
		ILCP92205
		REV E