

1

2

3

4

D

D

C

C

B

B

A

A

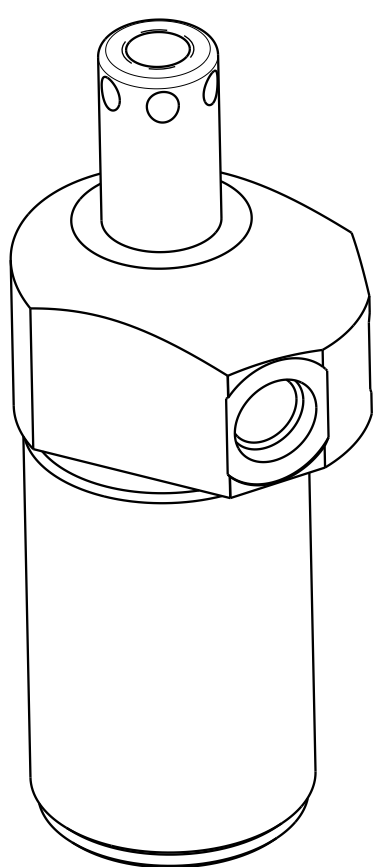

ILC14020901R REV C ECN 2510

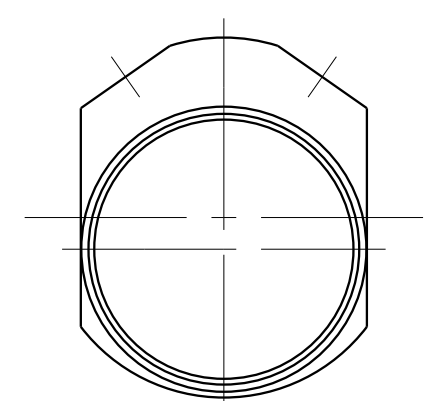
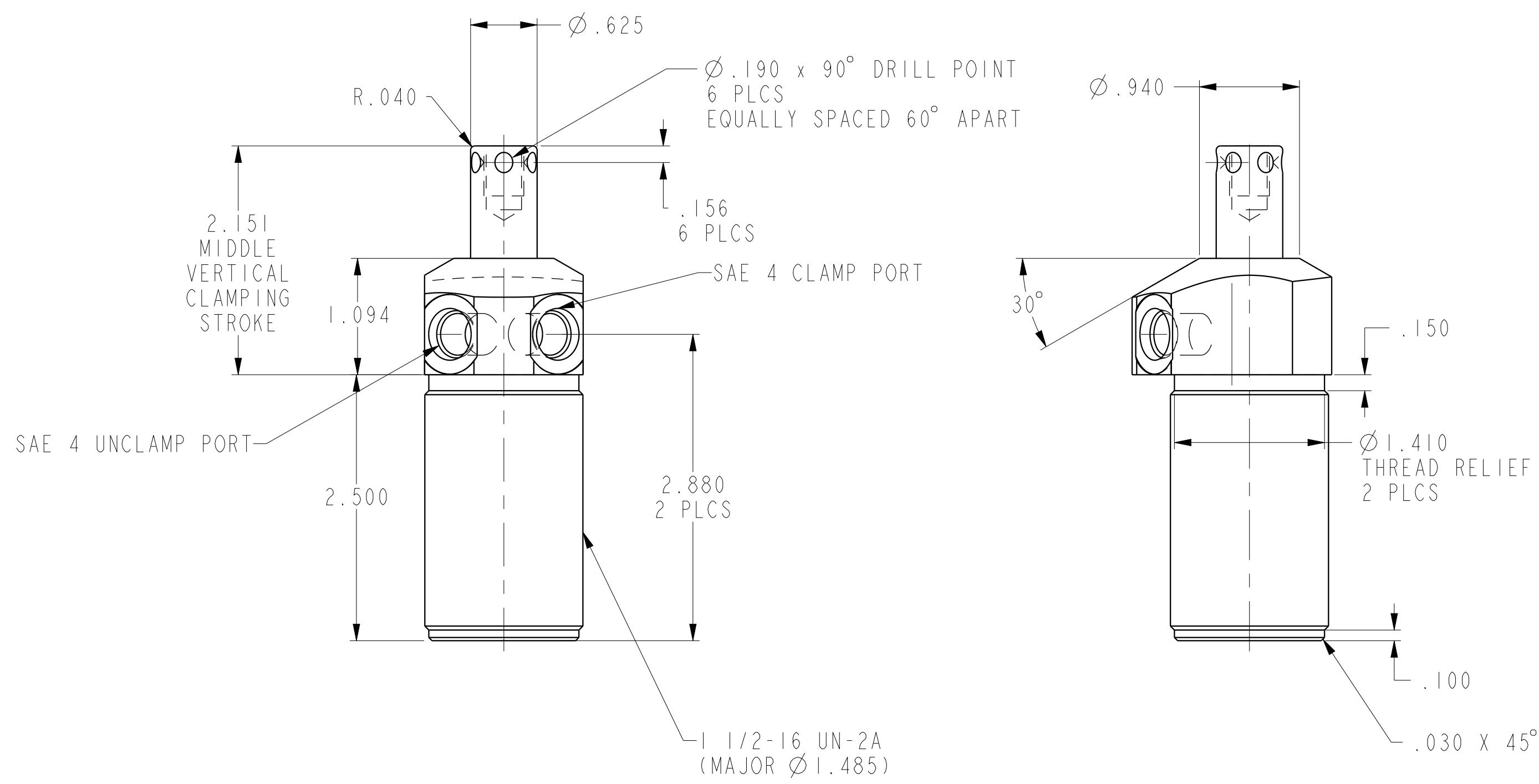
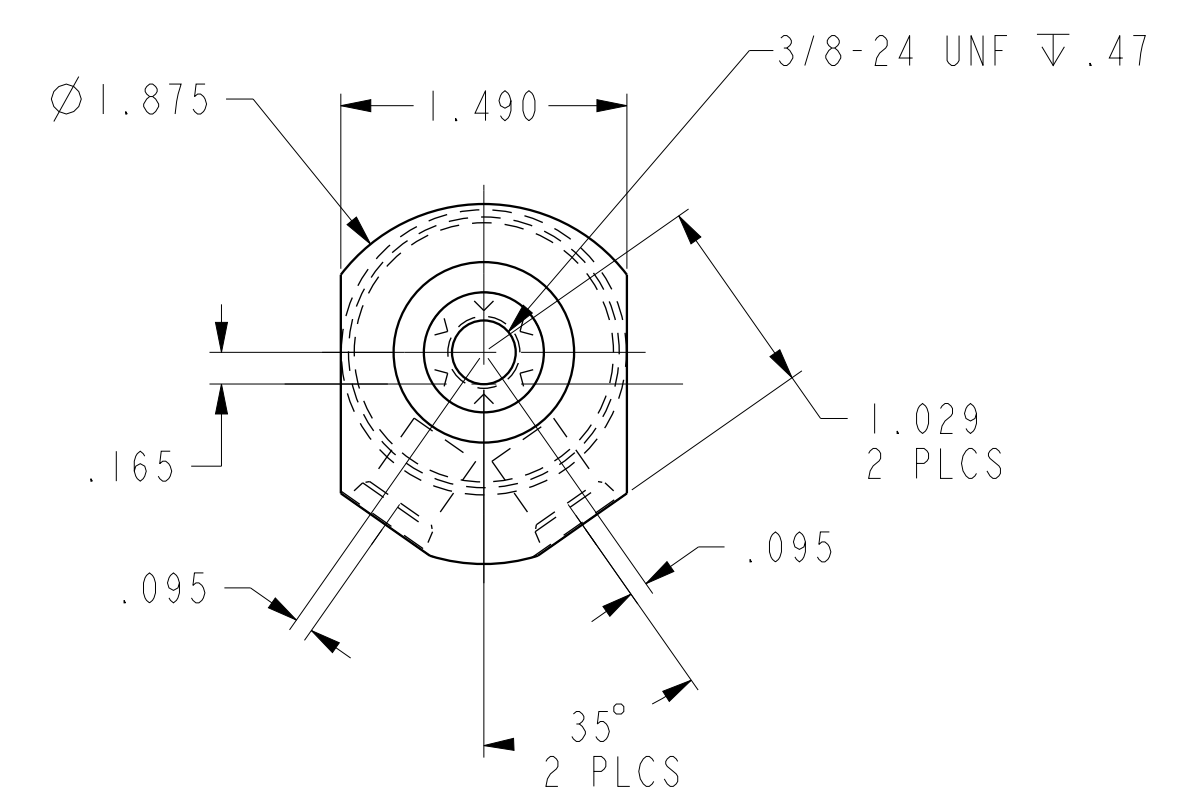

<b>CAD CONTROL DRAWING</b>			
		VEKTEK, INC. 1334 E. SIXTH AVE. P.O. BOX 625 EMPORIA, KS. 66801 U.S.A.	

C	2510	RELEASE	JDW	03/15/13	I4020901R	B	SC, TB, DA, HS, RH, I100
REV	IN ACCORDANCE WITH ECN	EFFECTIVE DATE	REVISED BY	DATE	REFERENCE MODEL	REF REV	
DRW BY:	K. ROEMER	DRAWING STATUS: <b>Released</b>			TOLERANCES DO NOT APPLY		SIZE
DATE:	02-01-05	PRODUCTION APPROVED FOR RELEASED STATUS ONLY			DIMENSIONS ARE NOMINAL		D
					I	ILC14020901R	REV C