

1

2

3

4

D

D

C

C

B

B

A

A

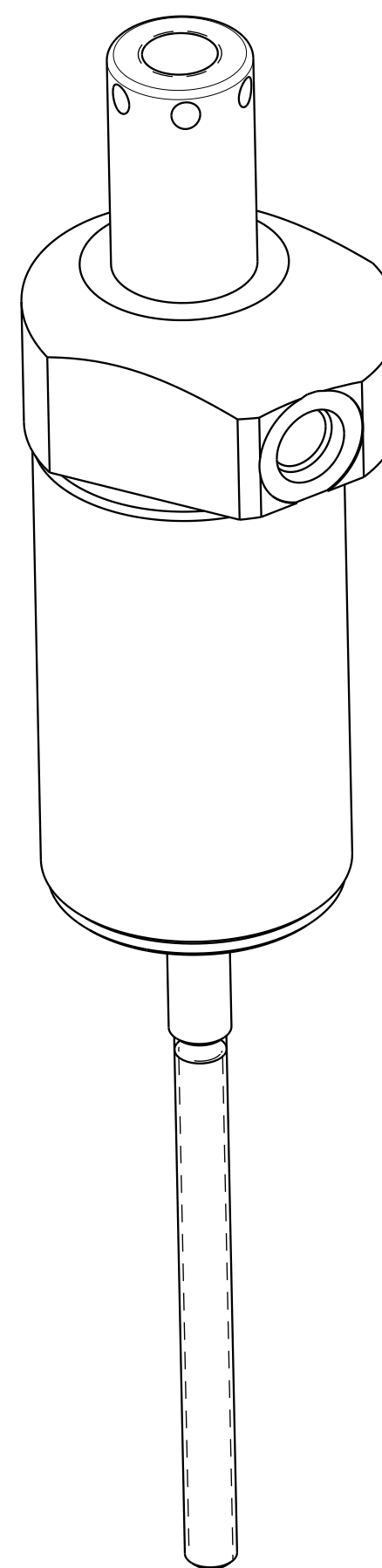

ILC14021301RPR REV C ECN 2510

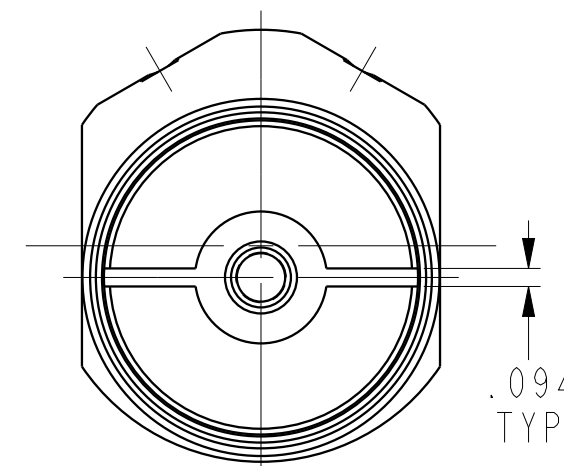
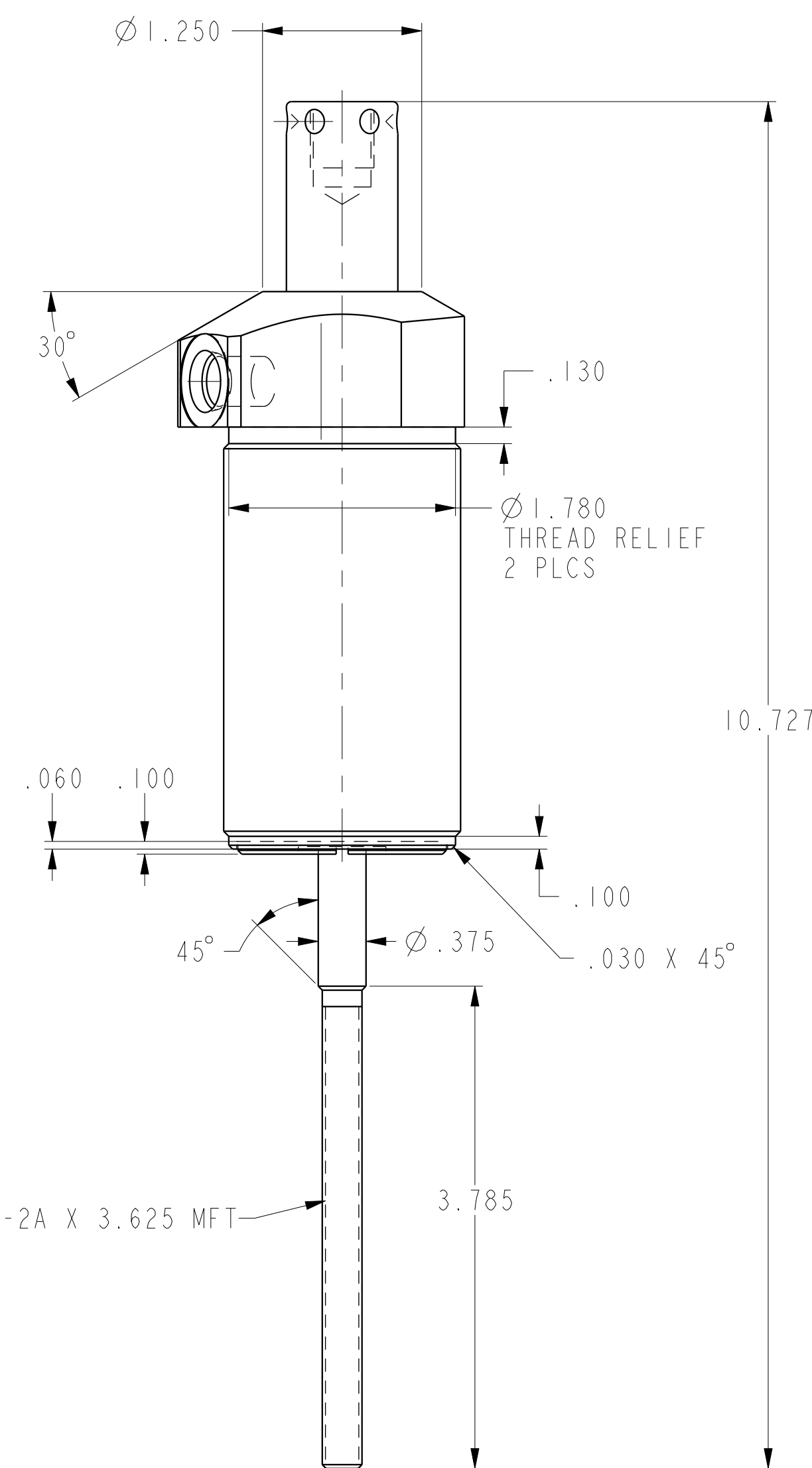
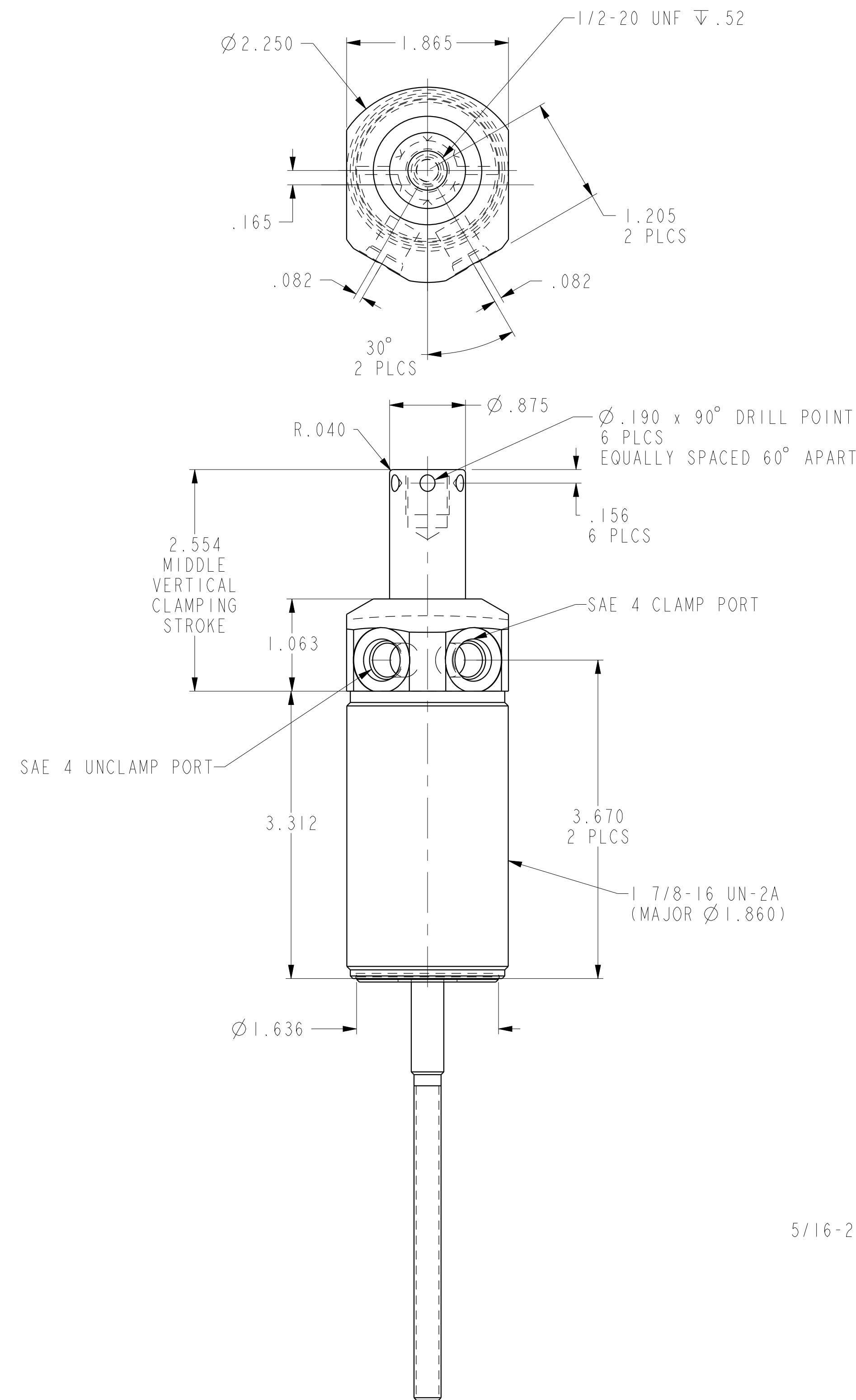

CAD CONTROL DRAWING

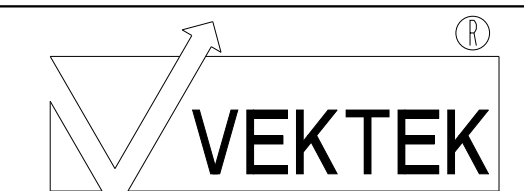

VEKTEK, INC.
1334 E. SIXTH AVE. P.O. BOX 625
EMPORIA, KS. 66801 U.S.A.

C	2510	RELEASE	JDW	03/15/13
REV	IN ACCORDANCE WITH ECN	EFFECTIVE DATE	REVISED BY	DATE
DRW BY:	DRAWING STATUS: Released			
DATE:	PRODUCTION APPROVED FOR RELEASED STATUS ONLY			

14021301RPR	A
REFERENCE MODEL	REF REV
TOLERANCES DO NOT APPLY DIMENSIONS ARE NOMINAL	

SC, TB, DA, HS, RH, PR, 2600
SIZE D
ILC14021301RPR
REV C

2

3

4

SHEET 1 OF 1