

1

2

3

4

D

D

C

C

B

B

A

A

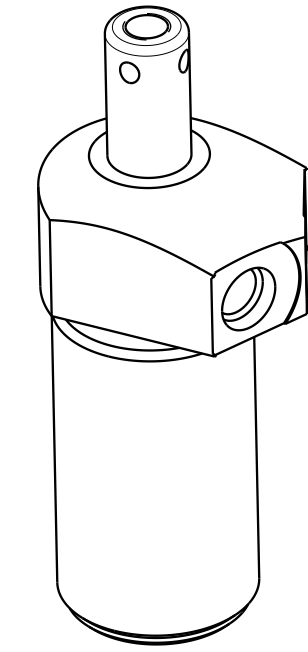
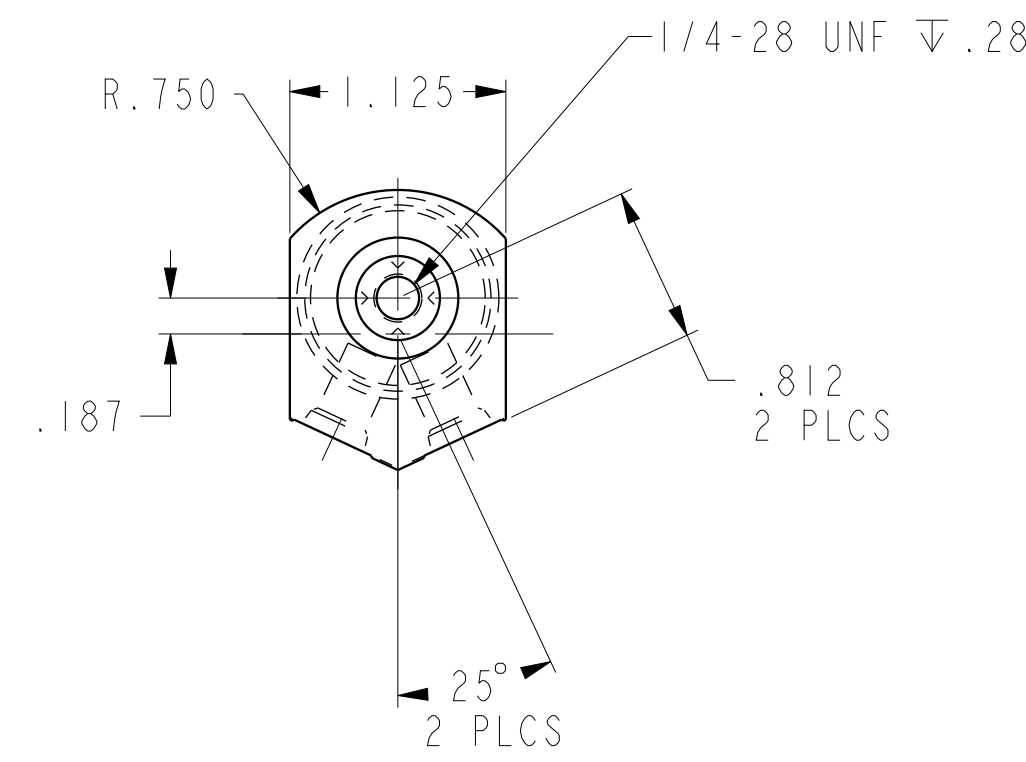

ILC15020503S REV A ECN 4609

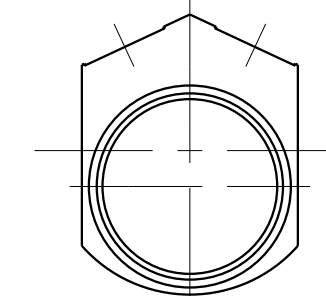
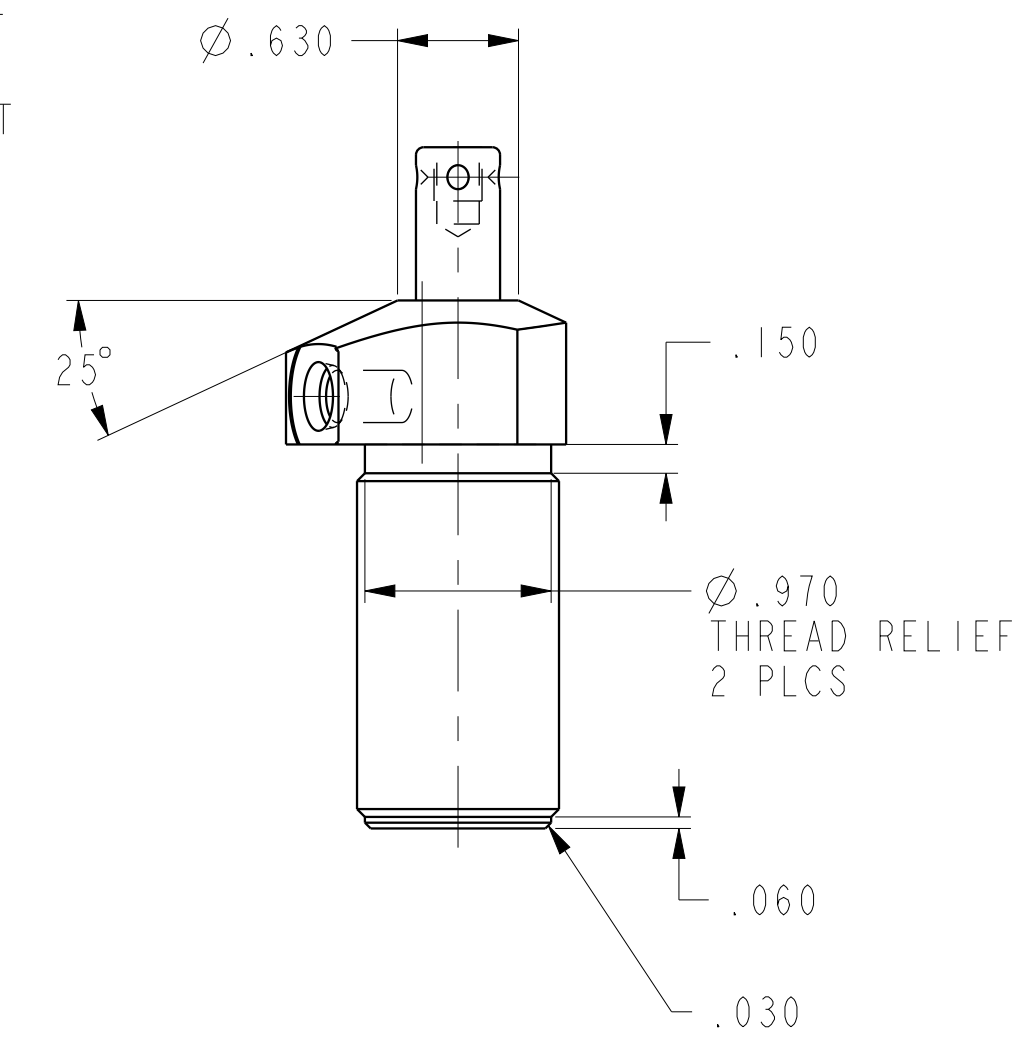
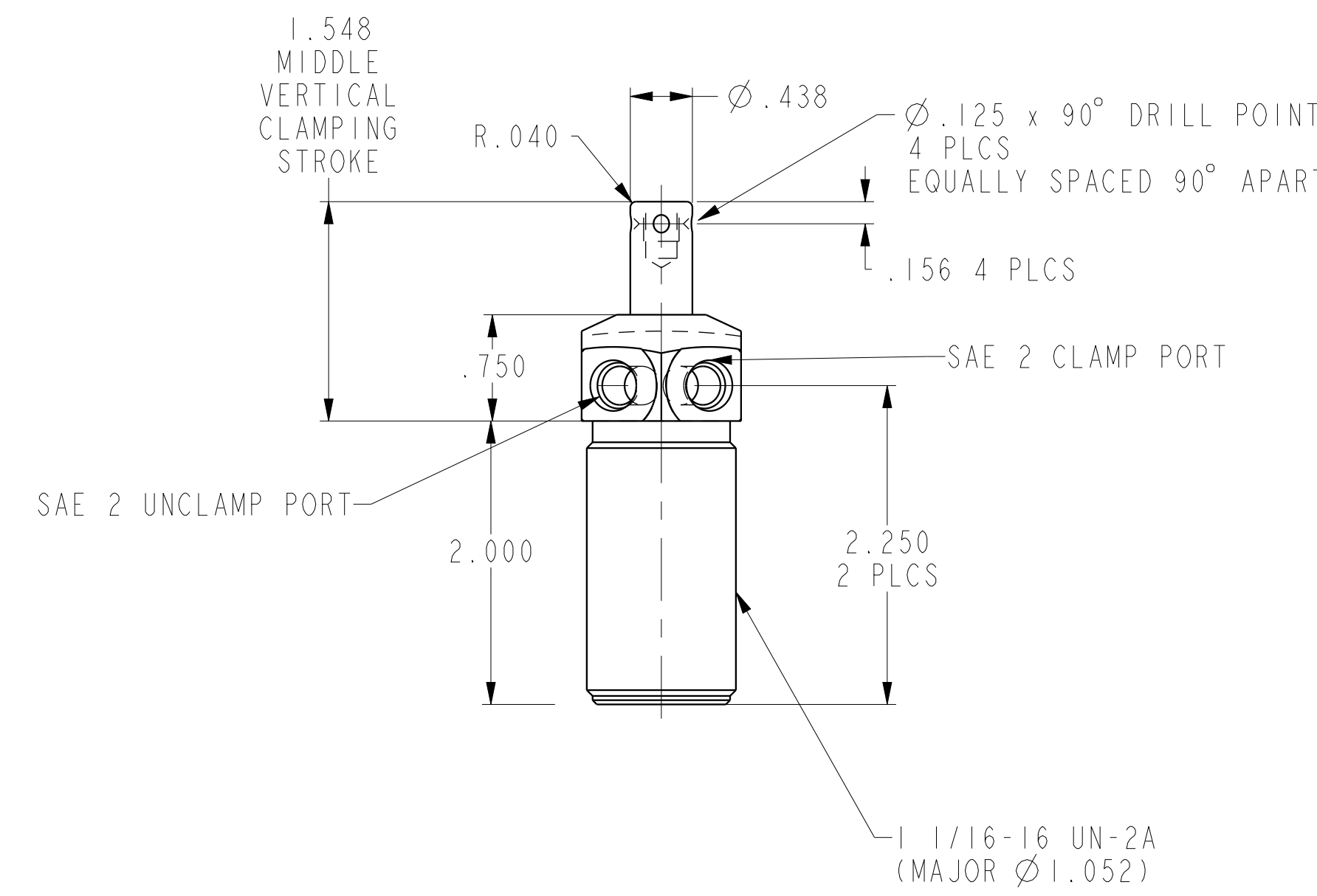

CAD CONTROL DRAWING



|         |                        |  |            |         |
|---------|------------------------|--|------------|---------|
| A       | 4609                   | RELEASE                                      | RLK        | 1/20/22 |
| REV     | IN ACCORDANCE WITH ECN | EFFECTIVE DATE                               | REVISED BY | DATE    |
| DRW BY: | RLK                    | DRAWING STATUS: Released                     |            |         |
| DATE:   | 1/20/22                | PRODUCTION APPROVED FOR RELEASED STATUS ONLY |            |         |

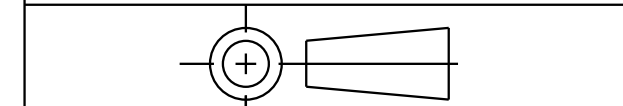

|  |         |
|--|---------|
| 15020503S                                      | A       |
| REFERENCE MODEL                                | REF REV |
| TOLERANCES DO NOT APPLY DIMENSIONS ARE NOMINAL |         |

|                      |
|----------------------|
| SC, TB, 450, DA, STR |
| SIZE D               |
| ILC15020503S         |
| REV A                |