

PORT #	TYPE	DESCRIPTION
A PORTS	SAE 6	A1 IS HYDRAULIC INPUT CONNECTOR TO CHECKED OUTPUT PORTS A2 AND A3.
B PORTS	SAE 6	B PORT IS PILOT FOR "A" PORT CHECK VALVE WHEN PRESSURIZED B PORTS OPEN CHECK ALLOWING FOR "A" PORTS DEPRESSURIZATION DURING UNCOUPLING PROCEDURE. B1 IS HYDRAULIC INPUT CONNECTOR TO OUTPUT PORTS B2 AND B3.
C PORTS	SAE 6	C1 IS HYDRAULIC INPUT CONNECTOR TO CHECKED OUTPUT PORTS C2 AND C3.
D PORTS	SAE 6	D PORT IS PILOT FOR C PORT CHECK VALVE. WHEN PRESSURIZED D PORTS OPEN CHECK ALLOWING FOR C PORTS DEPRESSURIZATION DURING UNCOUPLING PROCEDURE. D1 IS HYDRAULIC INPUT CONNECTOR TO OUTPUT PORTS D2 AND D3.
P PORTS	1/4 NPT	P1 DISCONNECT IS PNEUMATIC INPUT CONNECTOR TO BOTH P1 OUTPUT PORTS. P2 DISCONNECT IS PNEUMATIC INPUT CONNECTOR TO BOTH P2 OUTPUT PORTS. (NOTE: PNEUMATIC PORT DESIGNATIONS FOR REFERENCE ONLY, NOT LABELED ON PART)

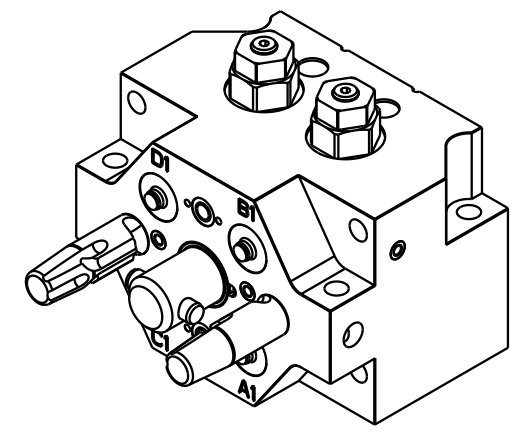

ILC56001000 REV B ECN 5863

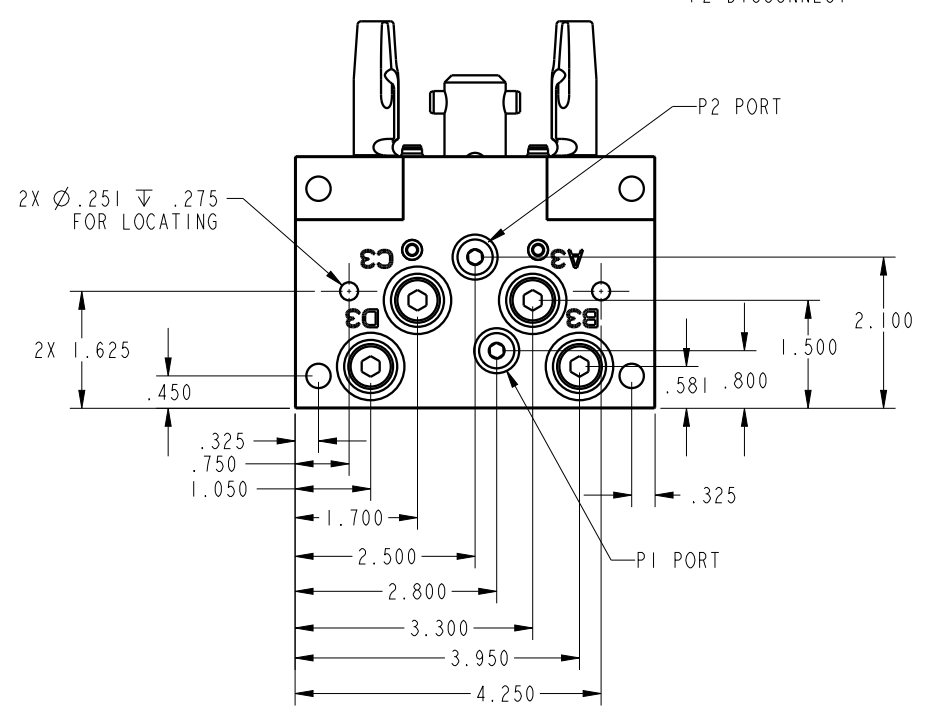
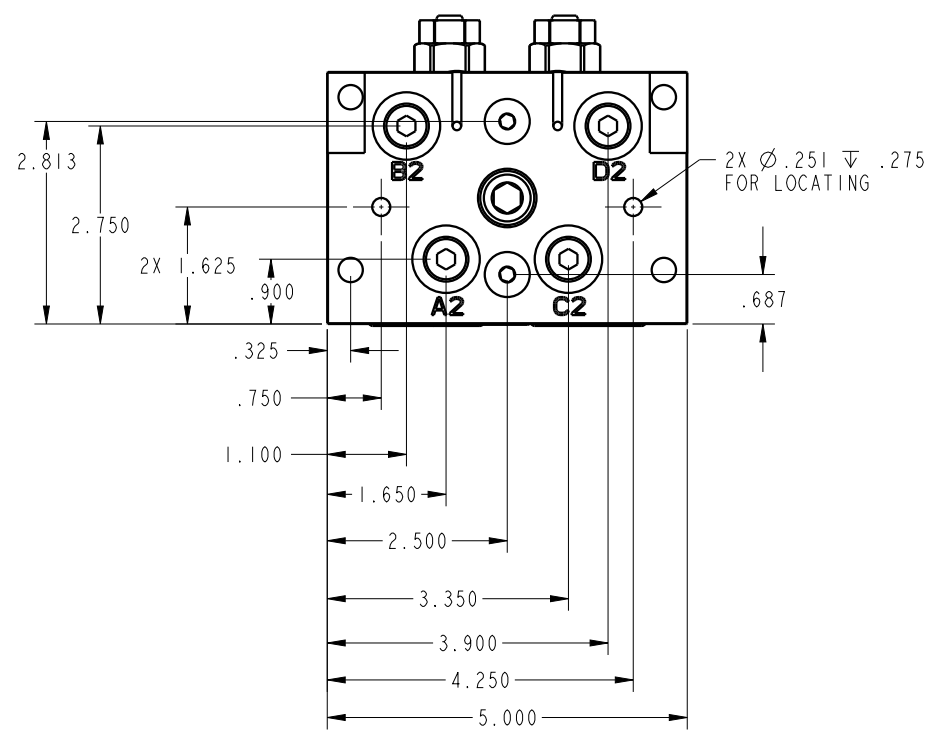
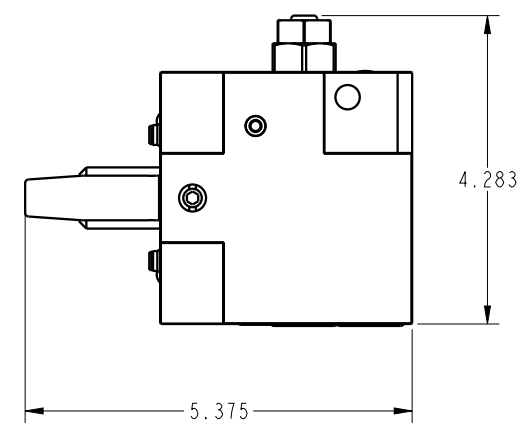
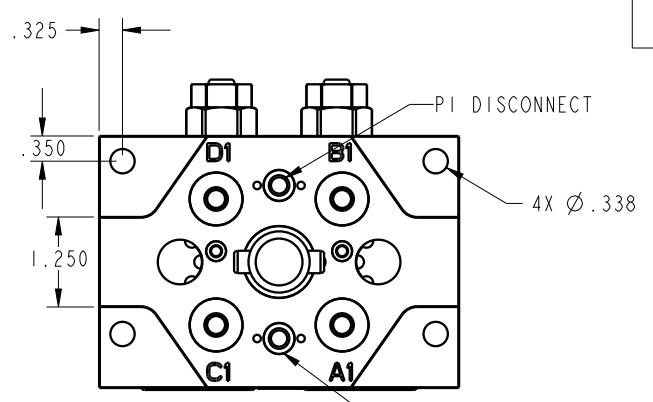
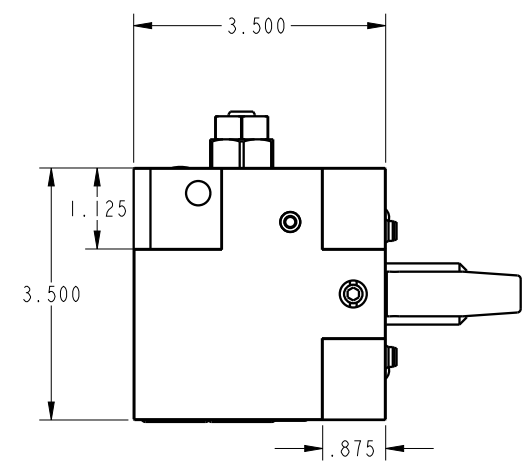

CAD CONTROL DRAWING		VEKTEK, INC. 1334 E. SIXTH AVE. P.O. BOX 625 EMPORIA, KS. 66801 U.S.A.

B	5863	RELEASE	NPETERS	2/4/26	ILC56001000	D	ILC, ASSY, AC, PALLET RECEIVER
REV	IN ACCORDANCE WITH ECN	EFFECTIVE DATE	REVISED BY	DATE	REFERENCE MODEL	REF REV	
DRW BY:	BDC	DRAWING STATUS: Released			TOLERANCES DO NOT APPLY DIMENSIONS ARE NOMINAL		SIZE B
DATE:	6/20/2023	PRODUCTION APPROVED FOR RELEASED STATUS ONLY					ILC56001000 REV B