

| MANIFOLD MOUNT O-RINGS | |
|------------------------|-------------------|
| CLOSE/OPEN | PURGE/LUBRICATION |
| Ø6x1.5 | Ø5x1.5 |

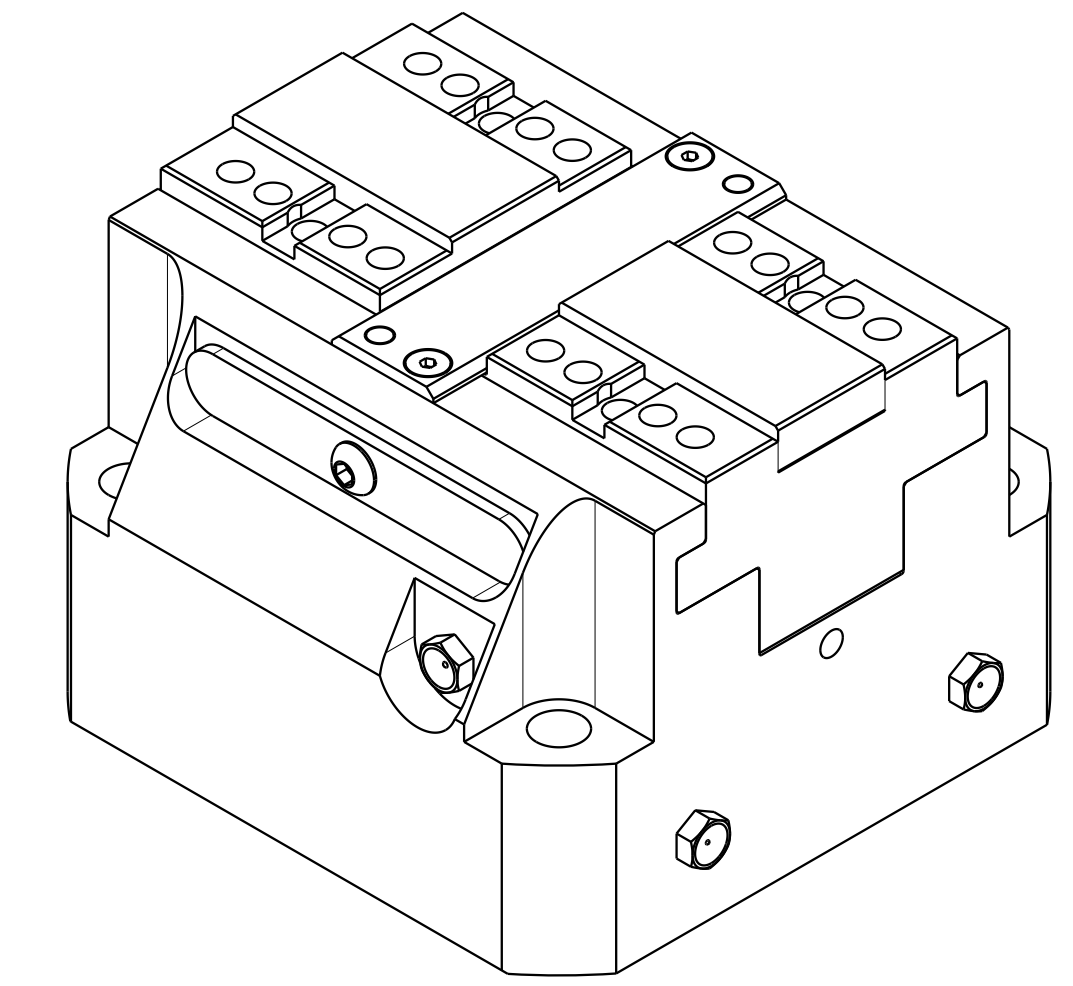

ILCM-VFB-100-C2-ID REV A ECN5231

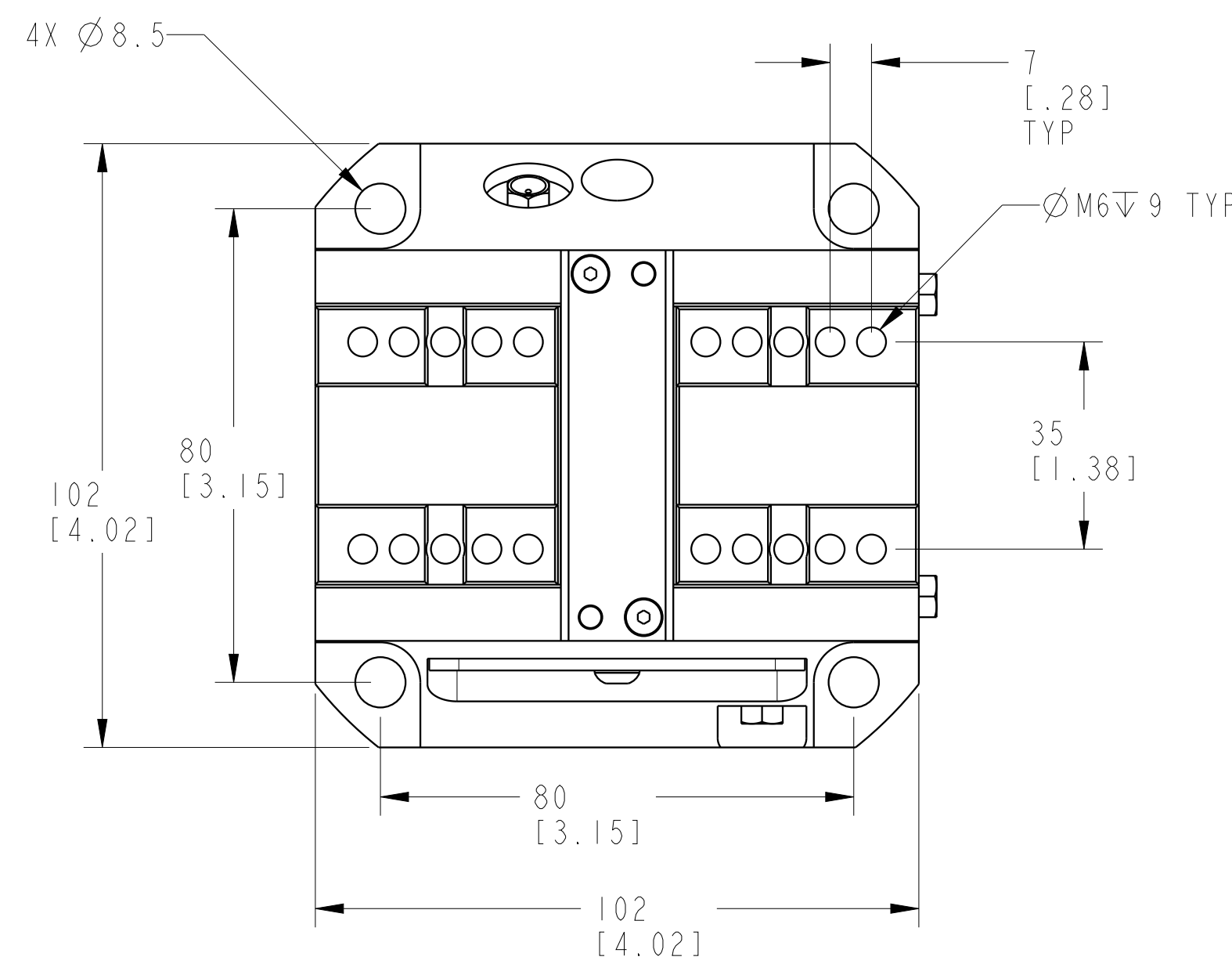
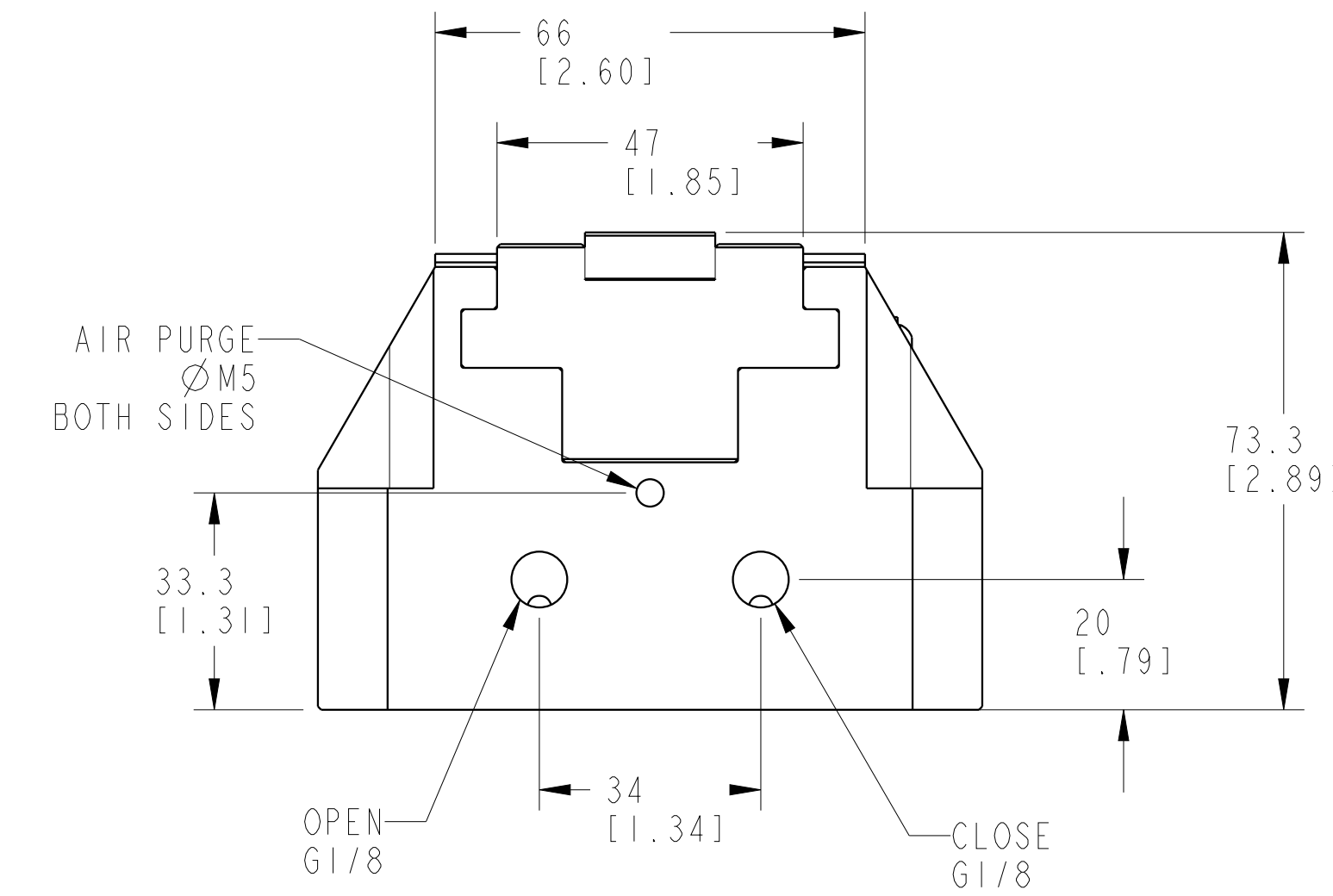
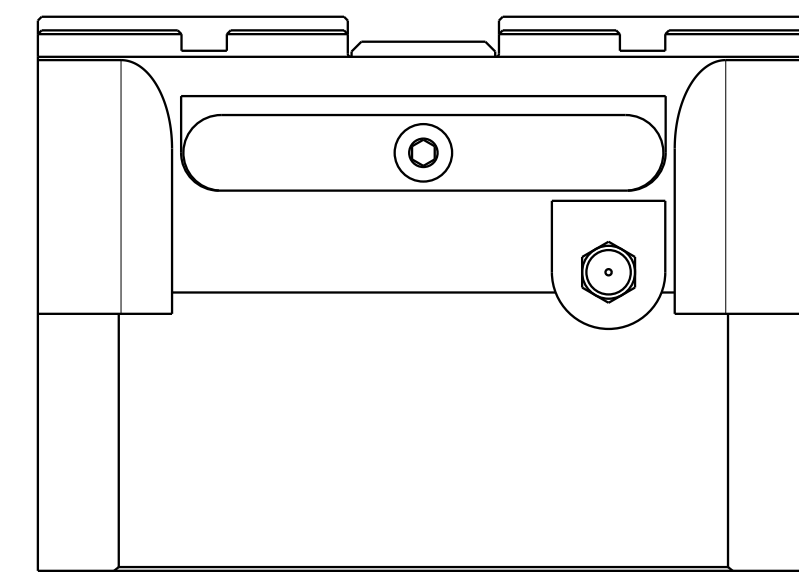

**CAD CONTROL
DRAWING**

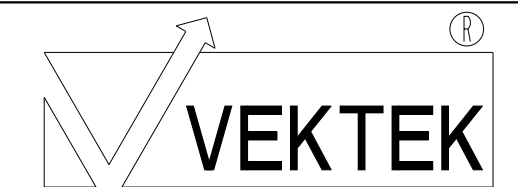

VEKTEK, INC.
1334 E. SIXTH AVE. P.O. BOX 625
EMPORIA, KS. 66801 U.S.A.

| | | | | | | | |
|---------|------------------------|--|------------|--------|-------------------------|-----------|----------------------------|
| A | 5231 | RELEASE | AJT | 2/6/24 | VFB-100-C2-ID | A | WISE, CENTER, 100, HF, HYD |
| REV | IN ACCORDANCE WITH ECN | EFFECTIVE DATE | REVISED BY | DATE | REFERENCE MODEL | REF REV | |
| DRW BY: | AJT | DRAWING STATUS: Released | | | TOLERANCES DO NOT APPLY | UNITS | SIZE |
| DATE: | 2/6/24 | PRODUCTION APPROVED FOR RELEASED STATUS ONLY | | | DIMENSIONS ARE NOMINAL | mm (inch) | D |
| | | | | | ILCM-VFB-100-C2-ID | REV | A |