

MANIFOLD MOUNT O-RINGS	
CLOSE/OPEN	PURGE/LUBRICATION
Ø6x1.5	Ø5x1.5

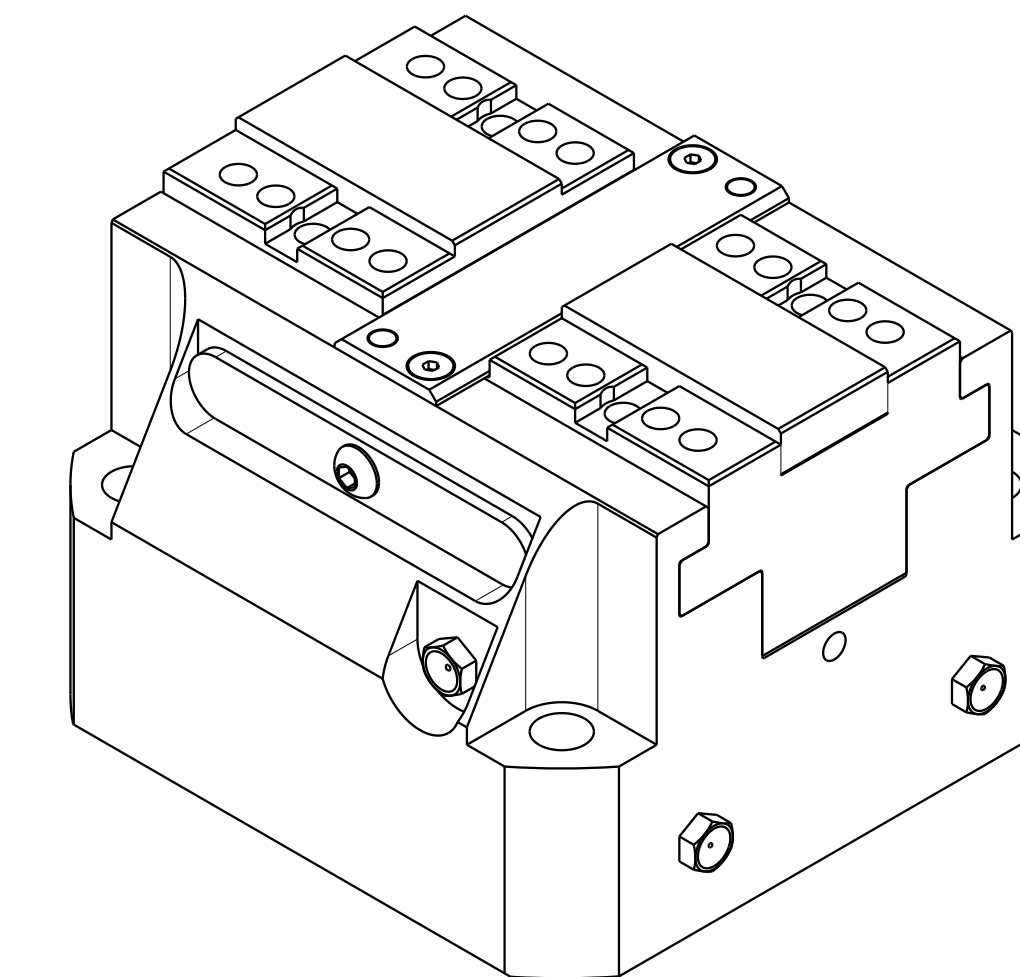

ILCM-VFB-100-C2-PN REV A ECN5231

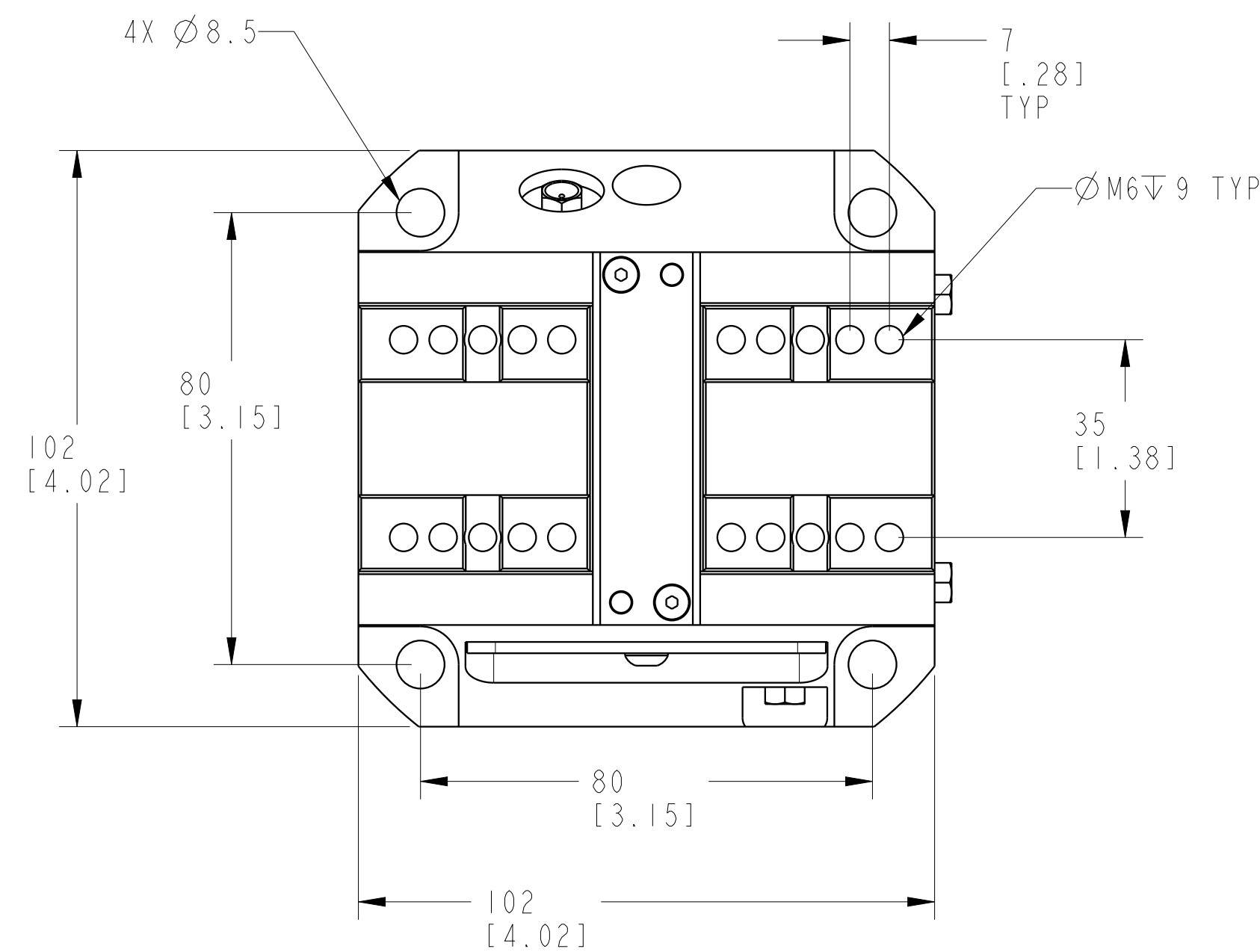
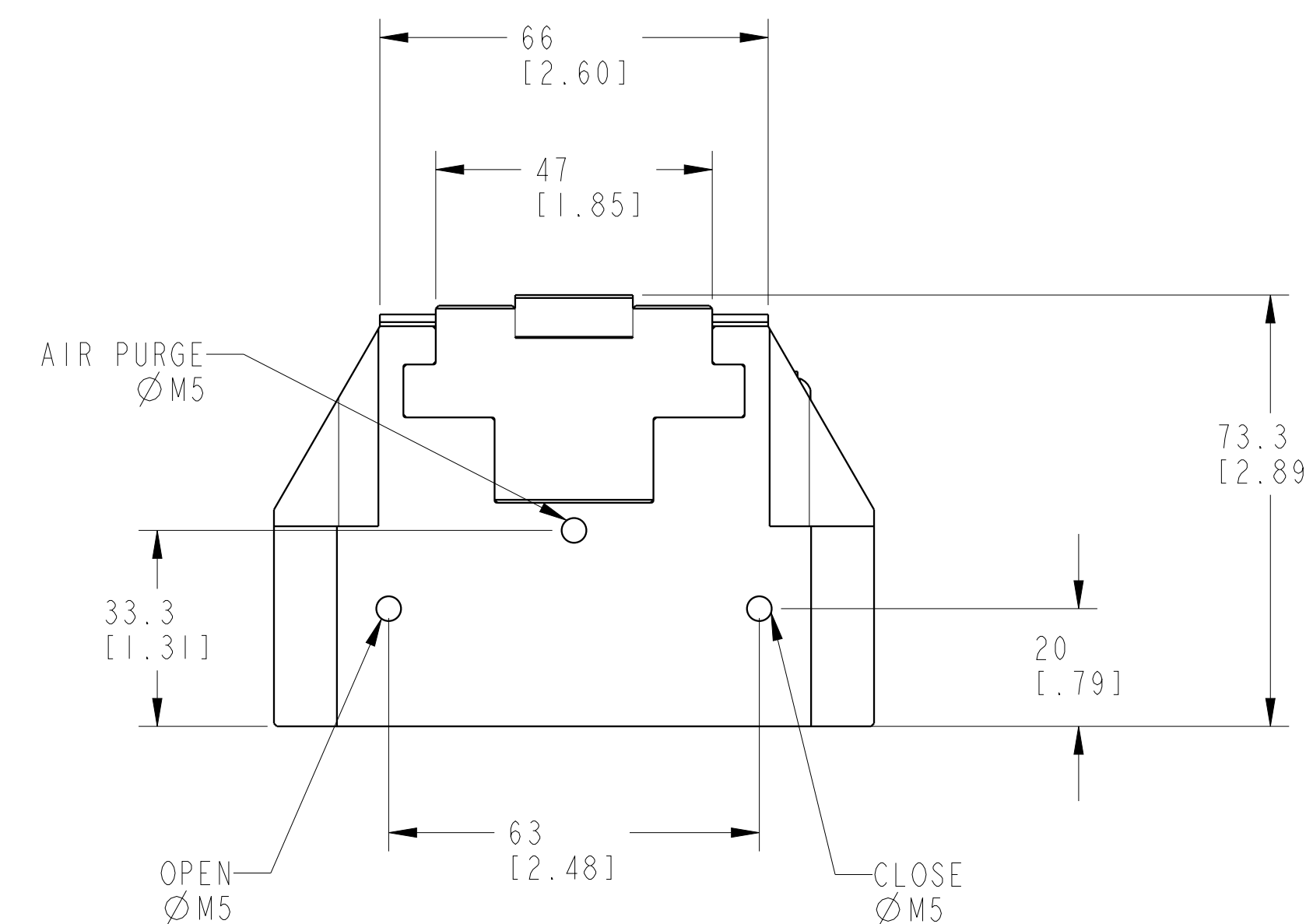
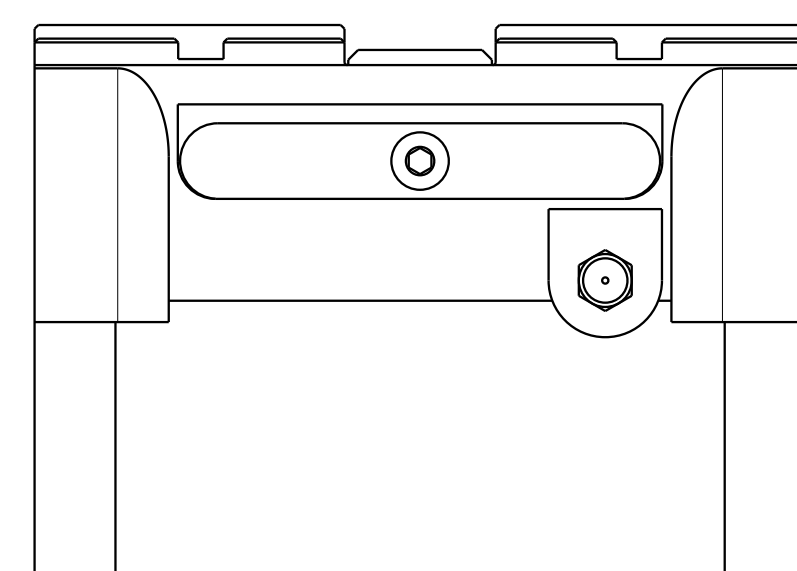

CAD CONTROL
DRAWING

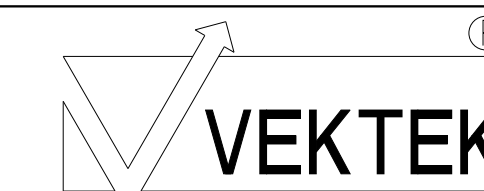

VEKTEK, INC.
1334 E. SIXTH AVE. P.O. BOX 625
EMPORIA, KS. 66801 U.S.A.

A	5231	RELEASE	AJT	2/6/24	VFB-100-C2-PN	A	WISE, CENTER, 100, HF, PNEU
REV	IN ACCORDANCE WITH ECN	EFFECTIVE DATE	REVISED BY	DATE	REFERENCE MODEL	REF REV	
DRW BY:	AJT	DRAWING STATUS: Released			TOLERANCES DO NOT APPLY	UNITS	SIZE
DATE:	2/5/24	PRODUCTION APPROVED FOR RELEASED STATUS ONLY			DIMENSIONS ARE NOMINAL	mm (inch)	D
					ILCM-VFB-100-C2-PN	REV	A