

ILCM-VGP-40-C1 REV A ECN5231

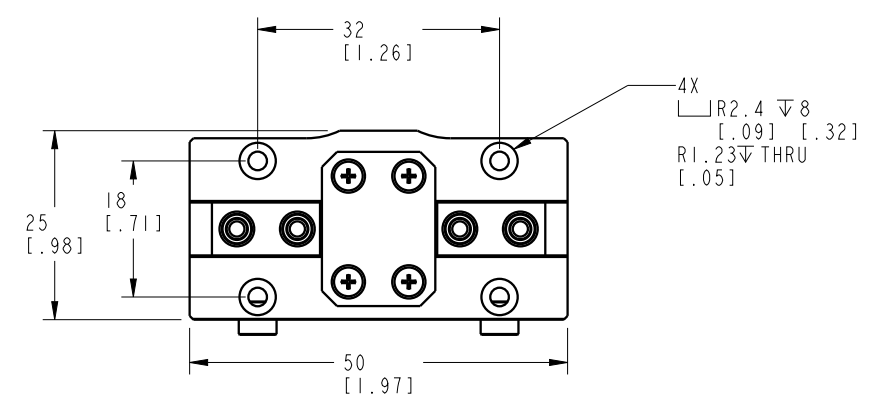

**CAD CONTROL  
DRAWING**

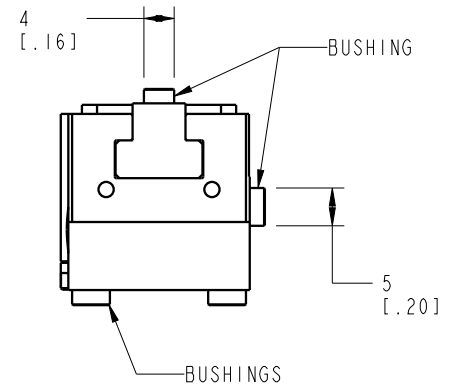
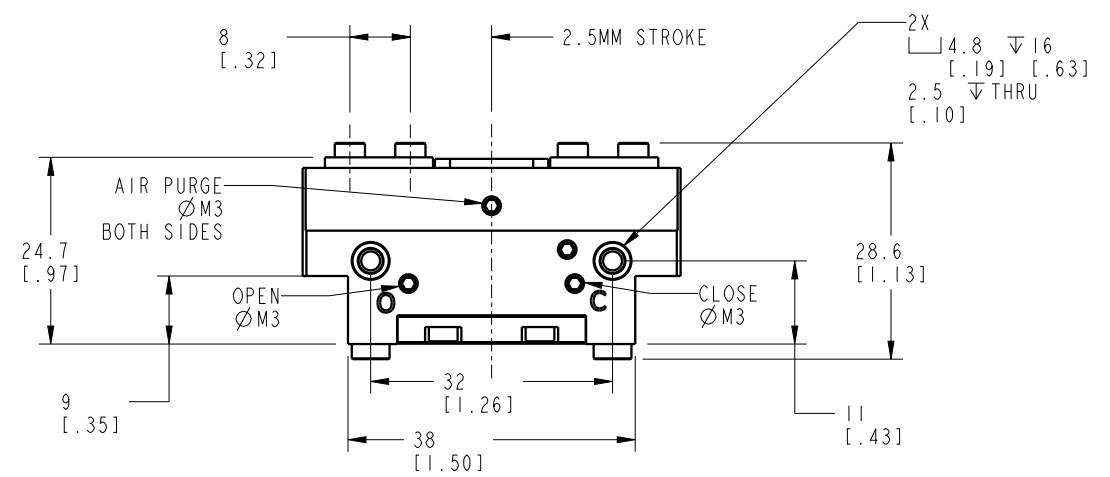

A	5231	RELEASE	AJT	2/6/24	VGP-40-C1	A	GRIPPER, 2-JAW, PL, 40, PNEU
REV	IN ACCORDANCE WITH ECN	EFFECTIVE DATE	REVISED BY	DATE	REFERENCE MODEL	REF REV	
DRW BY:	AJT	<b>DRAWING STATUS: Released</b>			TOLERANCES DO NOT APPLY	UNITS	SIZE
DATE:	1/31/24	PRODUCTION APPROVED FOR RELEASED STATUS ONLY			DIMENSIONS ARE NOMINAL	mm [inch]	B

SIZE	B	ILCM-VGP-40-C1	REV	A
------	---	----------------	-----	---

FORM FEG036, Rev. C