

ILCM-VGP-50-C2 REV A ECN5231

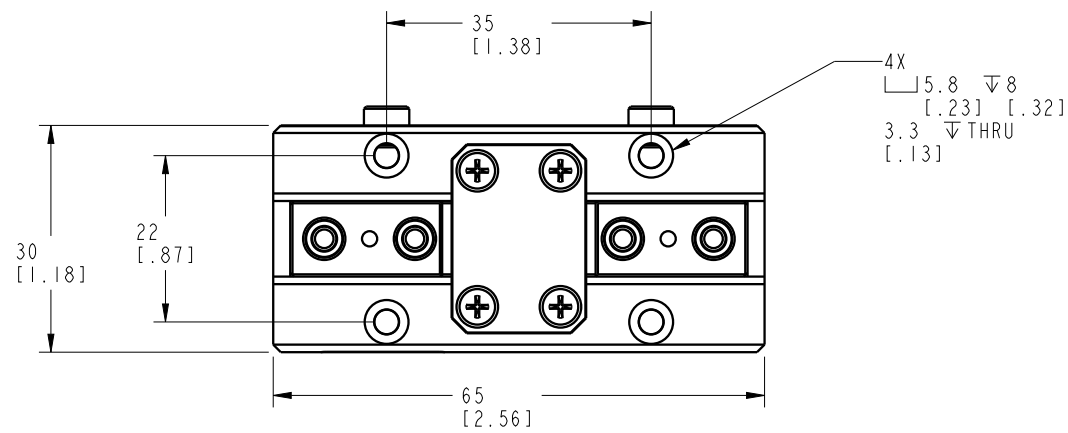

CAD CONTROL DRAWING

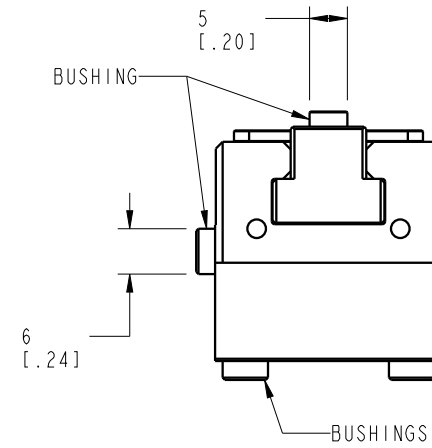
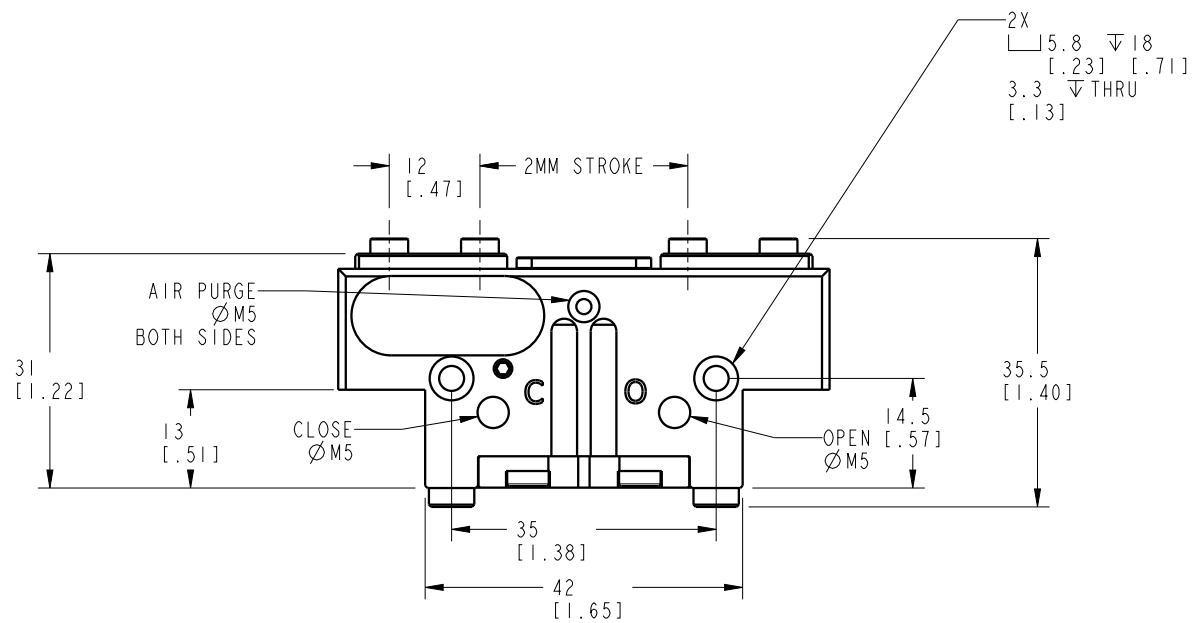
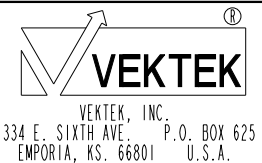

A	5231	RELEASE	AJT	2/6/24	VGP-50-C2	A	GRIPPER, 2-JAW, PL, 50, PNEU, HF
REV	IN ACCORDANCE WITH ECN	EFFECTIVE DATE	REVISED BY	DATE	REFERENCE MODEL	REF REV	
DRW BY:	AJT	DRAWING STATUS: Released			TOLERANCES DO NOT APPLY	UNITS	SIZE
DATE:	1/31/24	PRODUCTION APPROVED FOR RELEASED STATUS ONLY			DIMENSIONS ARE NOMINAL	mm [inch]	B
							ILCM-VGP-50-C2
							REV A

FORM FEG036, Rev. C

SHEET 1 OF 1