

ILCM-VMP-04 REV A ECN 5364

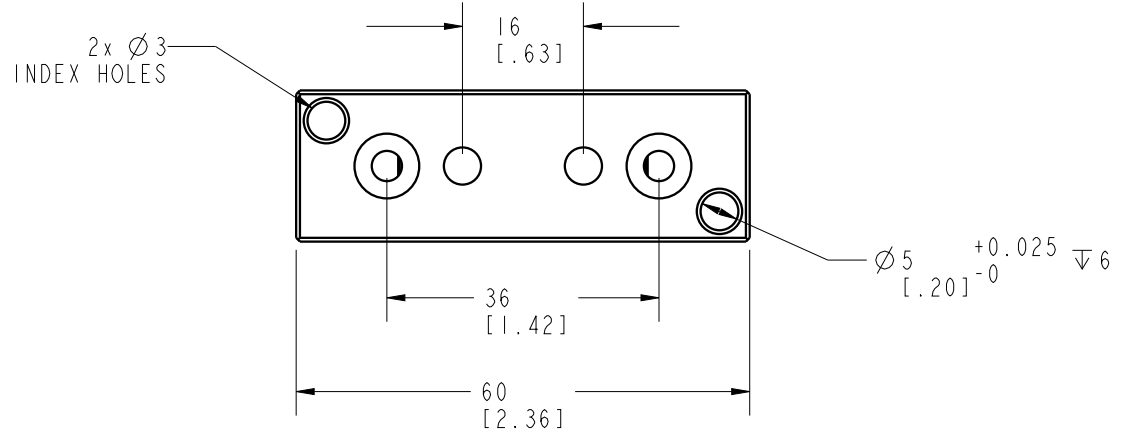

**CAD CONTROL DRAWING**



A	5364	RELEASE	AJT	7/10/24	VMP-04	A	OMIL, GRIPPER, VMP
REV	IN ACCORDANCE WITH ECN	EFFECTIVE DATE	REVISED BY	DATE	REFERENCE MODEL	REF REV	
DRW BY:	AJT	<b>DRAWING STATUS: Released</b>			TOLERANCES DO NOT APPLY	UNITS	SIZE
DATE:	7/10/24	PRODUCTION APPROVED FOR RELEASED STATUS ONLY			DIMENSIONS ARE NOMINAL	mm [inch]	B

ILCM-VMP-04 REV A

FORM FEG036, Rev. C