

I LCM-VZO-50-C2 REV A ECN 5359

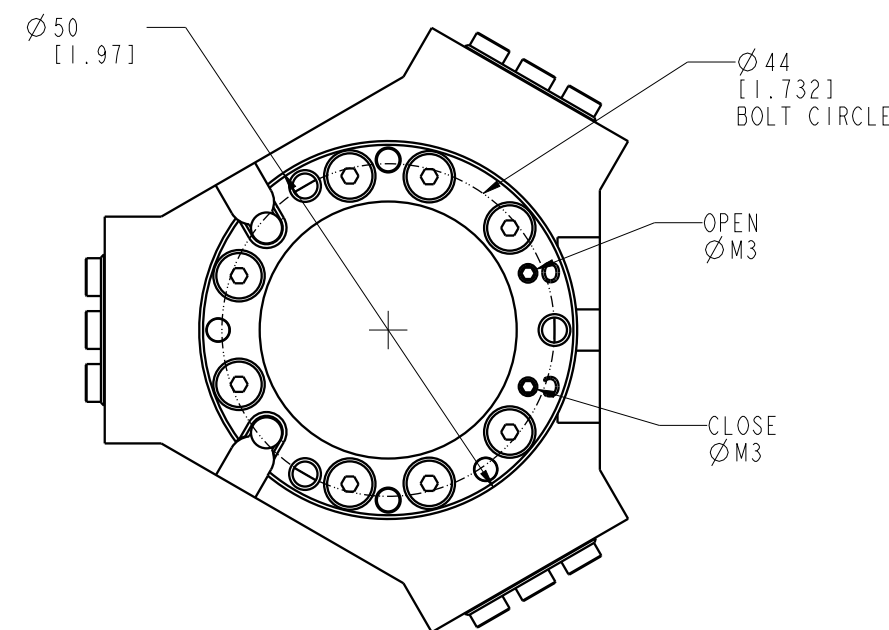

CAD CONTROL
DRAWING

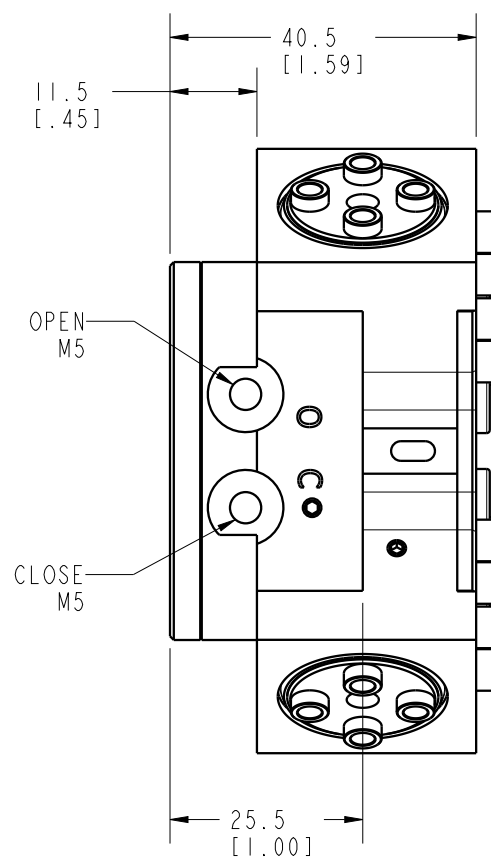
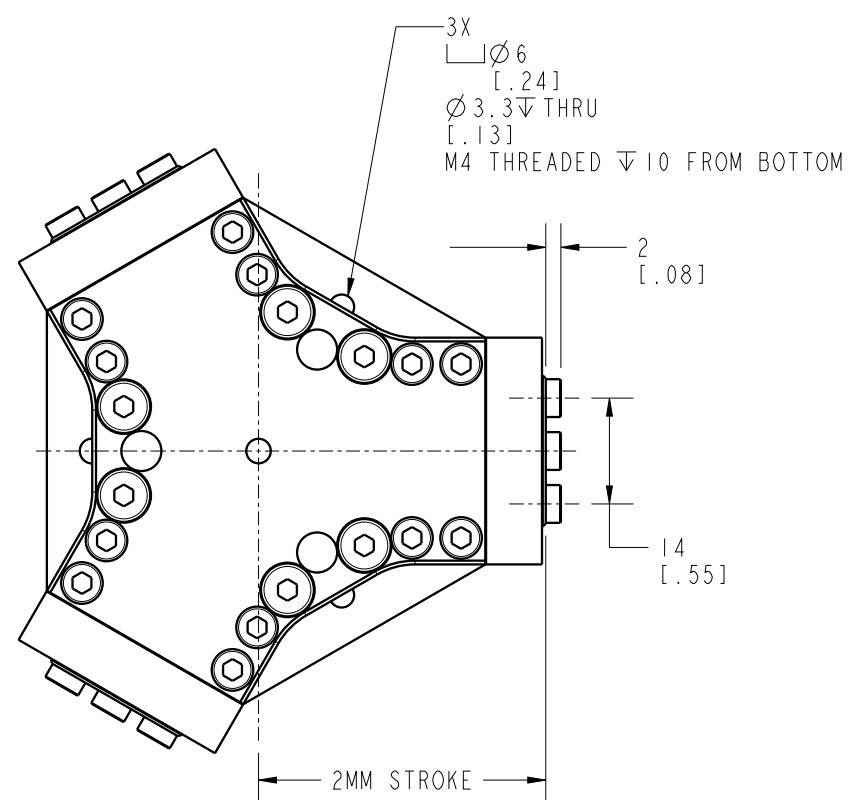

VEKTEK, INC.
1334 E. SIXTH AVE. P.O. BOX 625
EMPORIA, KS. 66801 U.S.A.

A	5359	RELEASE	AJT	6/25/24	VZO-50-C2	A	GRIPPER, 3-JAW, PL, 50, PNEU, IP67, HF	
REV	IN ACCORDANCE WITH ECN	EFFECTIVE DATE	REVISED BY	DATE	REFERENCE MODEL	REF REV		
DRW BY:	AJT	DRAWING STATUS: Released			TOLERANCES DO NOT APPLY	UNITS	SIZE	
DATE:	6/25/24	PRODUCTION APPROVED FOR RELEASED STATUS ONLY			DIMENSIONS ARE NOMINAL	mm [inch]	B	
							I LCM-VZO-50-C2	REV A

FORM FEG036, Rev. C

SHEET 1 OF 1