

I LCMVAP61025034 REV A ECN 5752

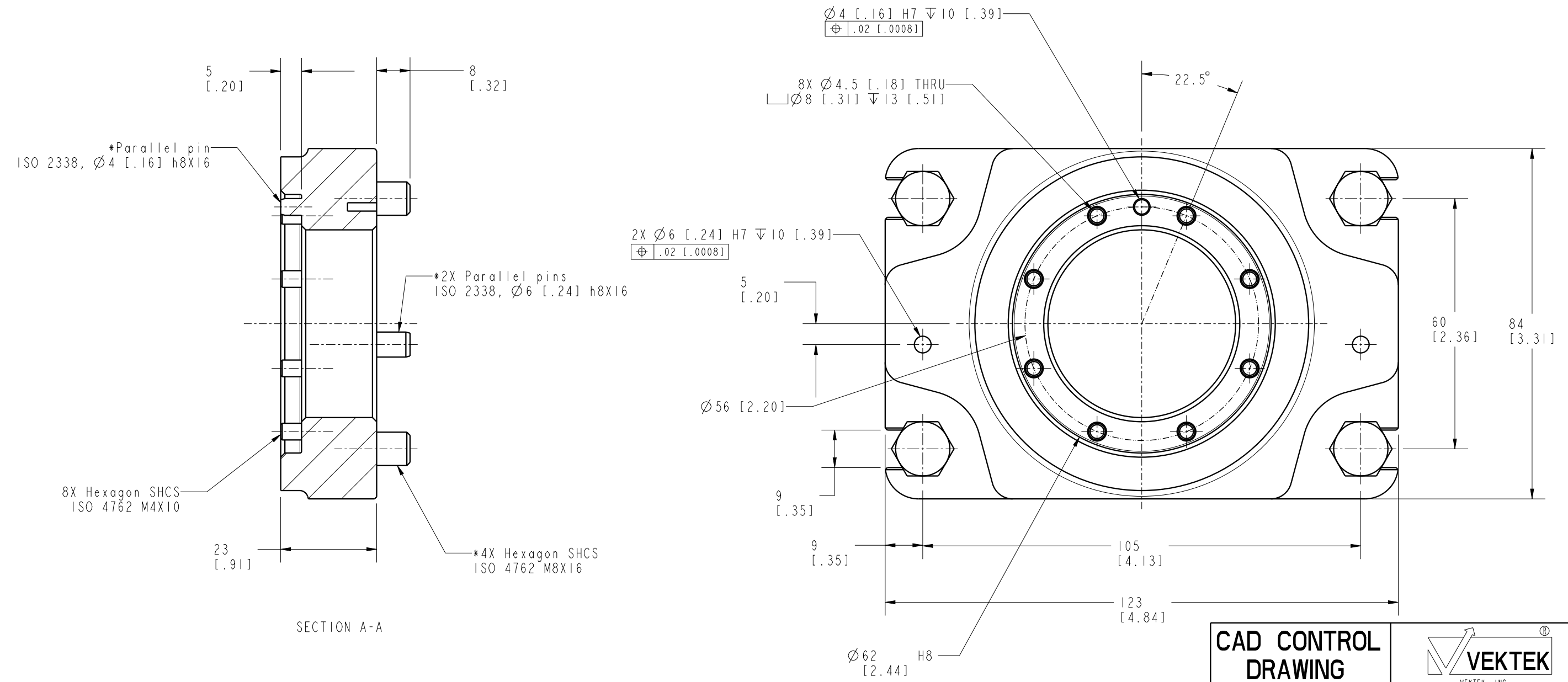

NOTES:  
1. \*Items are included

|                            |  |   |  |
|----------------------------|--|---|--|
| <b>CAD CONTROL DRAWING</b> |  |   |  |
|                            |  | VEKTEK, INC.<br>1334 E. SIXTH AVE., P.O. BOX 625<br>EMPORIA, KS. 66801 U.S.A. |  |

|         |                        |  |            |          |                         |           |                        |
|---------|------------------------|--|------------|----------|-------------------------|-----------|------------------------|
| A       | 5752                   | RELEASE                                      | ALS        | 10/22/25 | VAP61025034             | A         | IMPACT, RC, P09020, 56 |
| REV     | IN ACCORDANCE WITH ECN | EFFECTIVE DATE                               | REVISED BY | DATE     | REFERENCE MODEL         | REF REV   |                        |
| DRW BY: | ALS                    | <b>DRAWING STATUS: Released</b>              |            |          | TOLERANCES DO NOT APPLY | UNITS     | SIZE                   |
| DATE:   | 7/3/25                 | PRODUCTION APPROVED FOR RELEASED STATUS ONLY |            |          | DIMENSIONS ARE NOMINAL  | mm [inch] | B                      |
|         |                        |  |            |          | I LCMVAP61025034        |           | REV A                  |

FORM FEG036, Rev. C