

NO	QTY	PART NO	DESCRIPTION	SEAL KIT
1	1	21510004	NUT, JAM, HEX, M18-1.50	
2	3	23350087	SPRING, COMPRESSION	X
3	3	23650011	BALL, TUNGSTEN-CARBIDE, 8mm	X
4	2	39051080	O-RING, (10mm X 1)	X
5	1	39051085	O-RING, (63mm X 2)	X
6	2	39051088	O-RING, (8mm X 3)	X
7	1	39053046	SEAL, WIPER, SNAP IN, WED, 36, 94A, AU	X
8	1	39056006	SEAL, STEP, ROD, 36	X
9	1	39056025	SEAL, CAP, PISTON, 63, 90A, AU GRPHT FLD	X
10	2	43068006	PLUG, PORT, HOLLOW HEX, G1/4	
11	1	81400135	PLUNGER, SC, 7MPα, 63B, LH	
12	1	81400155	CAP, LC/SC, 7MPα, 63B	
13	2	81400201	PLUG, MANIFOLD, 7MPα, M10	
14	3	81400204	PIN, STOP, BALL, METRIC, 8mm BALL	X
N/A	N/A	L6014630	KIT, SEAL, SC, 7MPα, 63B	NOTED

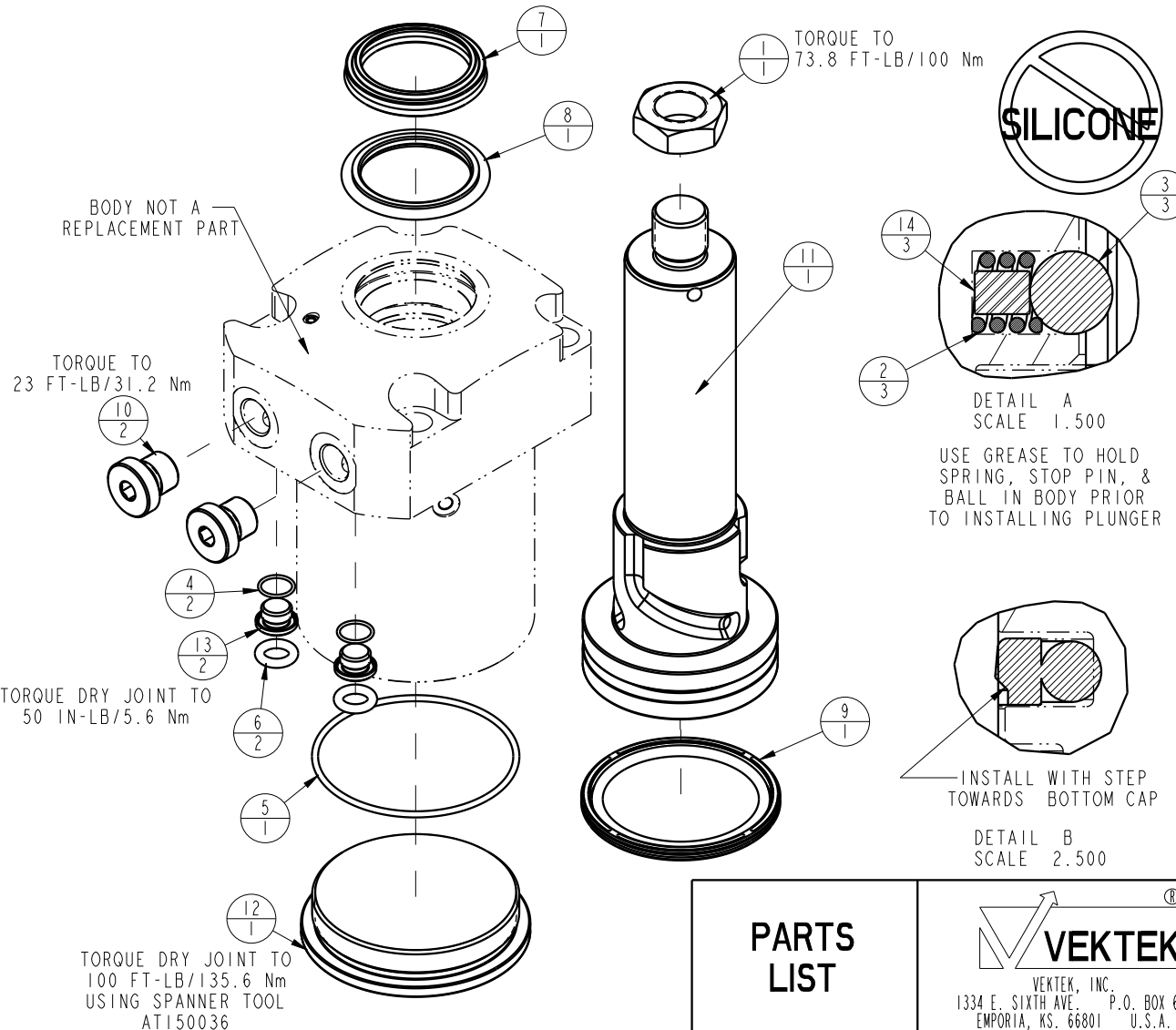

PARTS LIST	 VEKTEK VEKTEK, INC. 1334 E. SIXTH AVE. P.O. BOX 625 EMPORIA, KS. 66801 U.S.A.
	ASSEMBLIES AFFECTED L1406300L
PARTS LIST, ASSY, SC, TF, 7MPα, 63B, LH *****	SIZE A LPL1408
REV B	SHEET 1 OF 1

B	3273	RELEASE	JDW	08/15/18
REV	IN ACCORDANCE WITH ECN	EFFECTIVE DATE	REVISED BY	DATE
DRW BY:	OMITCHELL	DRAWING STATUS: Released		
DATE:	7-17-13	PRODUCTION APPROVED FOR RELEASED STATUS ONLY		