

NO	QTY	PART NO	DESCRIPTION	SEAL KIT
1	1	21510002	NUT, JAM, HEX, M12-1.50	
2	3	23350086	SPRING, COMPRESSION	X
3	3	23650010	BALL, TUNGSTEN-CARBIDE, 6mm	X
4	2	39051079	O-RING, (6mm X 1)	X
5	1	39051083	O-RING, (41mm X 2)	X
6	2	39051087	O-RING, (4mm X 3)	X
7	1	39053043	SEAL, WIPER, SNAP IN, WED, 22, 94A, AU	X
8	1	39056003	SEAL, STEP, ROD, 22	X
9	1	39056023	SEAL, CAP, PISTON, 40, 90A, AU GRPHT FLD	X
10	2	43068004	PLUG, SOCH, G1/8	
11	1	81400123	PLUNGER, SC, 7MPa, 40B, STR	
12	1	81400153	CAP, LC/SC, 7MPa, 40B	
13	2	81400200	PLUG, MANIFOLD, 7MPa, M6	
14	3	81400203	PIN, STOP, BALL, METRIC, 6mm BALL	X
N/A	N/A	L6014400	KIT, SEAL, SC, 7MPa, 40B	NOTED

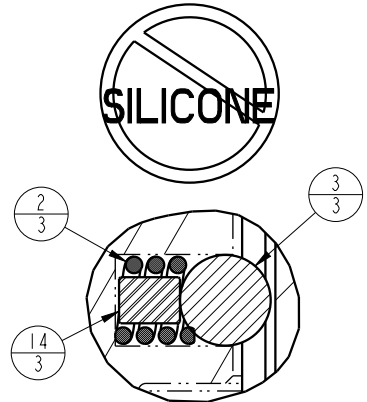

DETAIL A  
SCALE 2.000  
USE GREASE TO HOLD SPRING, STOP PIN, & BALL IN BODY PRIOR TO INSTALLING PLUNGER

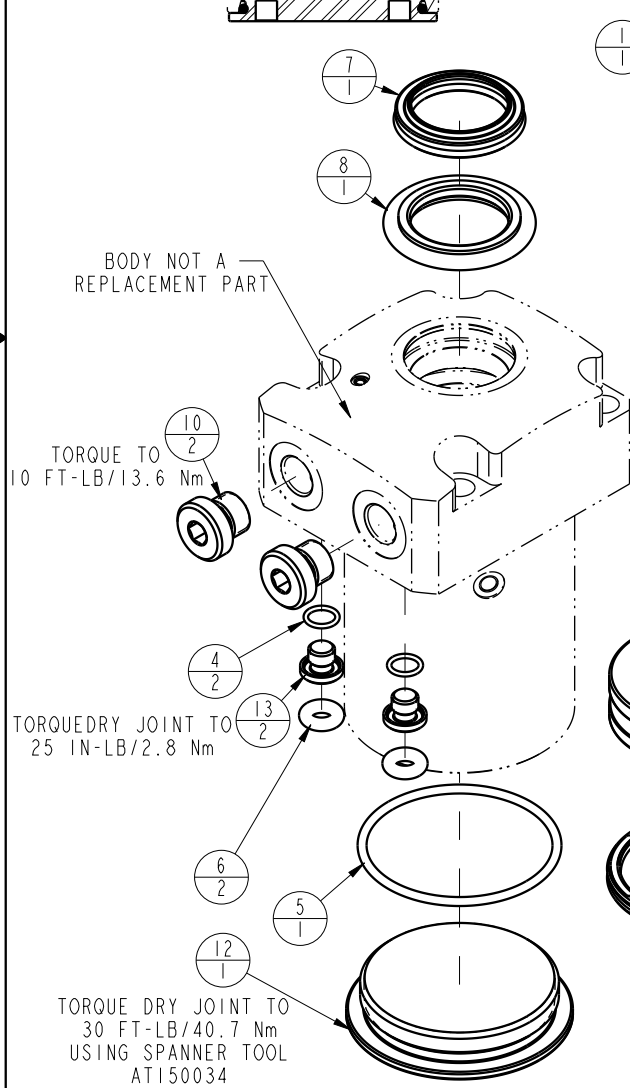
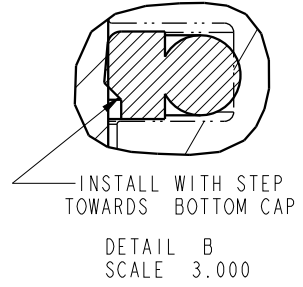

PARTS LIST		
	VEKTEK, INC. 1334 E. SIXTH AVE. P.O. BOX 625 EMPORIA, KS. 66801 U.S.A.	
ASSEMBLIES AFFECTED L1404000S	PARTS LIST, ASSY, SC, TF, 7MPa, 40B, STR	
SIZE A	LPL1450	REV B

B	3273	RELEASE	JDW	08/15/18
REV	IN ACCORDANCE WITH ECN	EFFECTIVE DATE	REVISED BY	DATE
DRW BY:	TWA	<b>DRAWING STATUS: Released</b>		
DATE:	9-15-16	PRODUCTION APPROVED FOR RELEASED STATUS ONLY		