

NO	QTY	PART NO	DESCRIPTION	STD SEAL KIT	FKM SEAL KIT	SPRING KIT
1	1	21500008	SCREW, CAP, BTNH, M6 X 10, ALY			
2	2	21500018	SCREW, CAP, SOCH, M3 X 5, ALY			
3	2	21500200	WASHER			
4	1	23310008	SPRING, COMPRESSION			X
5	1	23311017	SPRING, COMPRESSION			X
6	4	23600014	BALL, STEEL, ALLOY, .156	X	X	X
7	1	39010036	SEAL, BEVEL, 3/8 x 3/32 x 9/16	X	39052010	
8	1	39010038	SEAL, BEVEL, 7/16 x 3/32 x 5/8	X	39052014	
9	2	39050042	O-RING, (-011)	X	39051025	X
10	1	39053004	WIPER, SNAP-IN, (7/16)	X	X	
11	1	43068004	PLUG, SOCH, G1/8			
12	1	47510503	PLUNGER, SC, HS, 2KN, LH			
13	1	49001904	BREATHER, 1/8 BSPP			
14	1	81400028	RETAINER, SC, HS, 450			
15	1	81590501	ROD, SUPPORT, SPRING, SC, 450			X
16	3	90199956	ASSY, BALLSEAT, SC, 450	X	X	
17	1	39F54000	BU RING, (-111)	X	X	
18	1	39V00036	O-RING, (-908)	X	X	X
N/A	N/A	60414301	KIT, SEAL, STANDARD			
N/A	N/A	6V414301	KIT, SEAL, FKM			
N/A	N/A	61414001	KIT, SPRING			

B

B

A

A

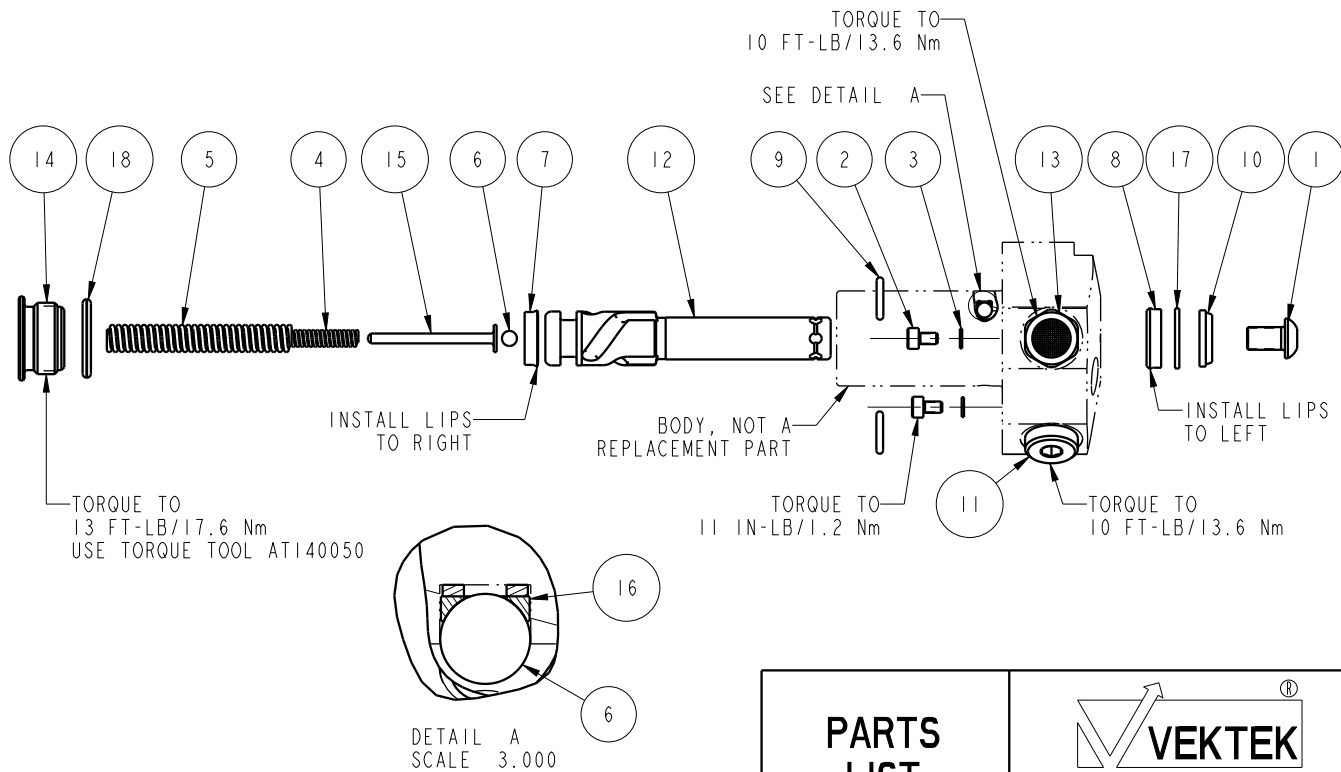

<b>PARTS LIST</b>	 <b>VEKTEK</b> VEKTEK, INC. 1334 E. SIXTH AVE. P.O. BOX 625 EMPORIA, KS. 66801 U.S.A.
	ASSEMBLIES AFFECTED 41460212
SIZE A	<b>MPL1402</b>
REV C	FORM FEG035_PL_ASIZE, REV. B

C	5279	RELEASE	ALS	4/25/24
REV	IN ACCORDANCE WITH ECN	EFFECTIVE DATE	REVISED BY	DATE
DRW BY:	JDW	<b>DRAWING STATUS: Released</b> PRODUCTION APPROVED FOR RELEASED STATUS ONLY		
DATE:	03/13/13			

1

2

SHEET 1 OF 1