

SECTION A-A

NO	QTY	PART NO	DESCRIPTION	STD SEAL KIT
1	2	21500051	SCREW, CAP, BTNH, M3 X 4, SSTL	
2	2	21500319	SCREW, SET, CUP PT, M6 X 1 X 12	
3	4	23050034	RING, RTNG, EXT, 0.312	X
4	8	23050035	RING, RTNG, EXT, 0.354	X
5	2	39051088	O-RING, (8mm X 3)	X
6	1	39051151	O-RING, (28mm X 2)	X
7	1	39052061	SEAL, ROD, RSD, 18, 85A, AU	X
8	1	39053042	SEAL, WIPER, SNAP IN, WED, 18, 94A, AU	X
9	1	39056033	SEAL, CAP, PISTON, 22.5, 94A, AU	X
10	2	43061122	PLUG, SOCH, METRIC, M8	
11	2	43068004	PLUG, SOCH, G1/8	
12	4	81600147	LINK, LC, 7MPa, 40B	
13	4	81600152	PIN, LINK, LC, 7MPa, 40B	
14	2	81600157	PIN, PLUNGER, LC, 7MPa, 40B	
15	1	81600273	CAP, LC, TL360, 2400/10.4kN	
16	1	81600282	PIVOT, TL360-TWIN, 2600 LB	
17	2	81600285	COVER, PIVOT, TL360-TWIN, 2600 LB	
18	1	81600294	PLUNGER, TL360-TWIN, 2600 LB	
N/A	N/A	60160508	KIT, SEAL,	NOTED

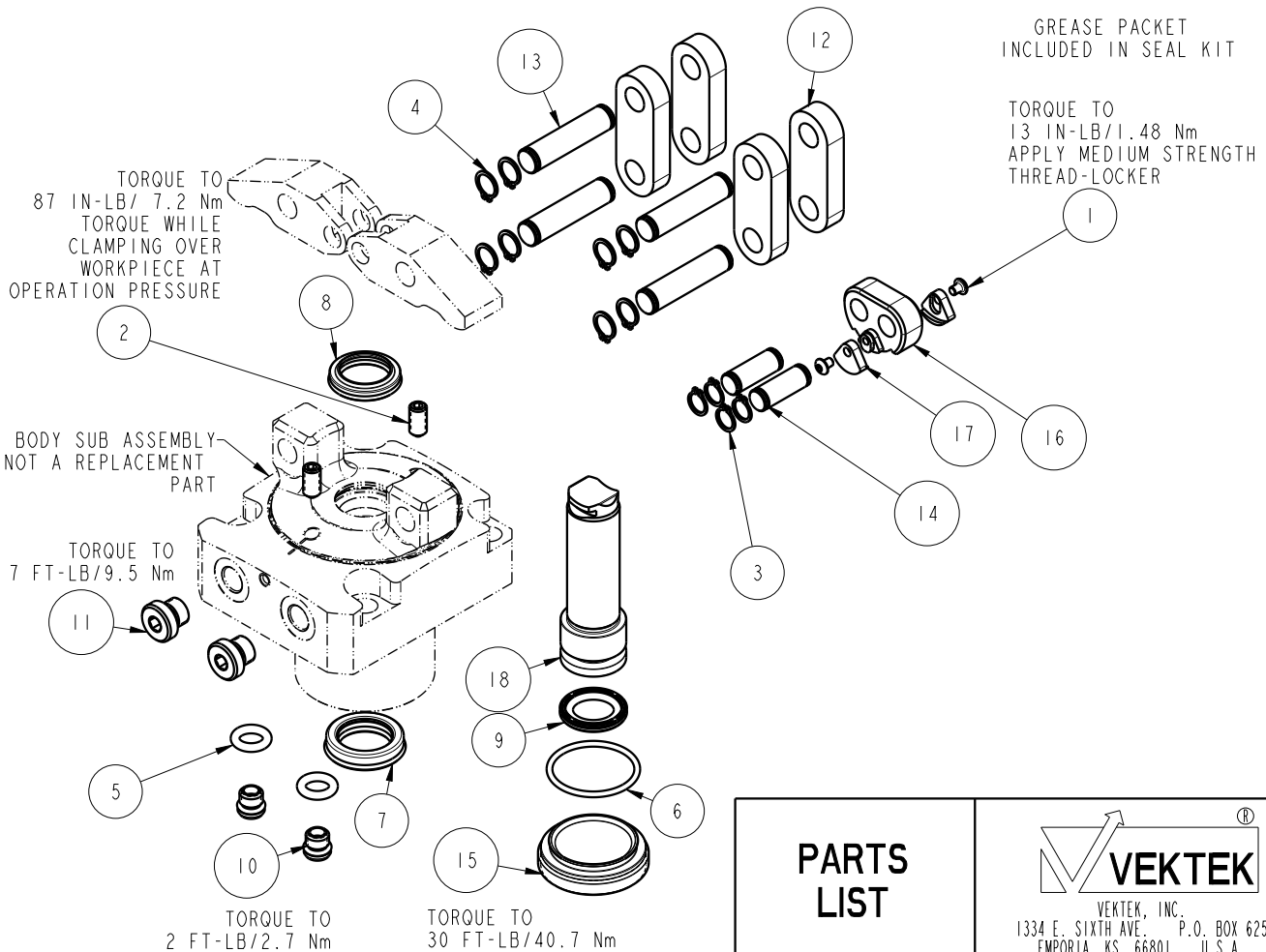

PARTS LIST



VEKTEK, INC.
1334 E. SIXTH AVE. P.O. BOX 625
EMPORIA, KS. 66801 U.S.A.

ASSEMBLIES AFFECTED
41622220

PARTS LIST, ASSY, LC, TL360-TWIN, DA, 11.57 LN

SIZE
A MPL1627

REV
A

A	4723	RELEASE	BDC	7/19/2022
REV	IN ACCORDANCE WITH ECN	EFFECTIVE DATE	REVISED BY	DATE
DRW BY:	BDC	DRAWING STATUS: Released		
DATE:	07/20/22	PRODUCTION APPROVED FOR RELEASED STATUS ONLY		