



The Productivity Devices Company



AIR HYDRAULIC PUMP #45-5820-02 / 45-5820-01

**VEKTEK, INC.
1334 EAST SIXTH AVENUE
EMPORIA, KS 66801
1-913-365-1045**



NOTICE

FAILURE TO HEED THE FOLLOWING INFORMATION WILL VOID WARRANTY

Most malfunctions in new equipment are the result of improper operation and/or improper set-up and assembly. Please read the following information.

- Remove pump from shipping container...but DO NOT remove any plugs or valves until the unit is ready to be fully assembled to prevent dirt or foreign matter from contaminating system or oil.
- Visually inspect all components for shipping damage. If any damage is found, notify carrier immediately and contact the factory.
- Use only cylinders, hoses and equipment rated for 350 BAR operating pressure. Use of cylinders or other components rated for less than 350 BAR may result in system failure, which may result in bodily injury or property damage.

Safety Data Sheet

According to OSHA HCS 2012 (29 CFR 1910.1200)



SECTION 1: Identification

Product Identifier **Megaflow® AW Hydraulic Oil**

Other means of identification Phillips 66 Megaflow® AW Hydraulic Oil 22
Phillips 66 Megaflow® AW Hydraulic Oil 32
Phillips 66 Megaflow® AW Hydraulic Oil 46
Phillips 66 Megaflow® AW Hydraulic Oil 68
Phillips 66 Megaflow® AW Hydraulic Oil 100
Phillips 66 Megaflow® AW Hydraulic Oil 150
Phillips 66 Megaflow® AW Hydraulic Oil 220
Phillips 66 Megaflow® AW Hydraulic Oil 320

SDS Number **LBPH814637**

Relevant identified uses Hydraulic Fluid

Uses advised against All others

24 Hour Emergency Phone Number CHEMTREC 1-800-424-9300
CHEMTREC Mexico 01-800-681-9531

Manufacturer/Supplier Phillips 66 Lubricants P.O. Box 4428 Houston, TX 77210	SDS Information Phone: 800-762-0942 Email: SDS@P66.com URL:www.Phillips66.com	Customer Service U.S.: 800-368-7128 or International: 1-832-765-2500 Technical Information 1-877-445-9198
--	---	--

SECTION 2: Hazard identification

Classified Hazards	Hazards Not Otherwise Classified (HNOC)
This material is not hazardous under the criteria of the Federal OSHA Hazard Communication Standard 29CFR 1910.1200.	PHNOC: None known HHNOC: None known

Label Elements
No classified hazards

SECTION 3: Composition/information on ingredients

Chemical Name	CASRN	Concentration ¹
Distillates, petroleum, hydrotreated heavy paraffinic	64742-54-7	>99

¹ All concentrations are percent by weight unless ingredient is a gas. Gas concentrations are in percent by volume.

SECTION 4: First aid measures

Eye Contact: If irritation or redness develops from exposure, flush eyes with clean water. If symptoms persist, seek medical attention.

Skin Contact: First aid is not normally required. However, it is good practice to wash any chemical from the skin. If product is injected into or under the skin, or into any part of the body, regardless of the appearance of the wound or its size, the individual should be evaluated immediately by a physician. (see Note to Physician)

Inhalation: First aid is not normally required. If breathing difficulties develop, move victim away from source of exposure and into fresh air in a position comfortable for breathing. Seek immediate medical attention.

Ingestion: First aid is not normally required; however, if swallowed and symptoms develop, seek medical attention.

Most important symptoms and effects, both acute and delayed: Inhalation of oil mists or vapors generated at elevated temperatures may cause respiratory irritation. Accidental ingestion can result in minor irritation of the digestive tract, nausea and diarrhea.

Notes to Physician: Acute aspirations of large amounts of oil-laden material may produce a serious aspiration pneumonia. Patients who aspirate these oils should be followed for the development of long-term sequelae. Inhalation exposure to oil mists below current workplace exposure limits is unlikely to cause pulmonary abnormalities. When using high-pressure equipment, injection of product under the skin can occur. In this case, the casualty should be sent immediately to the hospital. Do not wait for symptoms to develop. High-pressure hydrocarbon injection injuries may produce substantial necrosis of underlying tissue despite an innocuous appearing external wound. These injuries often require extensive emergency surgical debridement and all injuries should be evaluated by a specialist in order to assess the extent of injury. Early surgical treatment within the first few hours may significantly reduce the ultimate extent of injury.

SECTION 5: Firefighting measures

NFPA 704 Hazard Class

Health: 0 Flammability: 1 Instability: 0



0 (Minimal)
1 (Slight)
2 (Moderate)
3 (Serious)
4 (Severe)

Extinguishing Media: Dry chemical, carbon dioxide, foam, or water spray is recommended. Water or foam may cause frothing of materials heated above 212°F / 100°C. Carbon dioxide can displace oxygen. Use caution when applying carbon dioxide in confined spaces. Simultaneous use of foam and water on the same surface is to be avoided as water destroys the foam.

Specific hazards arising from the chemical

Unusual Fire & Explosion Hazards: This material may burn, but will not ignite readily. If container is not properly cooled, it can rupture in the heat of a fire.

Hazardous Combustion Products: Combustion may yield smoke, carbon monoxide, and other products of incomplete combustion. Oxides of sulfur, nitrogen or phosphorus may also be formed.

Special protective actions for firefighters: For fires beyond the initial stage, emergency responders in the immediate hazard area should wear protective clothing. When the potential chemical hazard is unknown, in enclosed or confined spaces, a self contained breathing apparatus should be worn. In addition, wear other appropriate protective equipment as conditions warrant (see Section 8).

Isolate the hazard area and deny entry to unnecessary and unprotected personnel Stop spill/release if it can be done safely. Move undamaged containers from immediate hazard area if it can be done safely Water spray may be useful in minimizing or dispersing vapors and to protect personnel. Cool equipment exposed to fire with water, if it can be done safely. Avoid spreading burning liquid with water used for cooling purposes.

See Section 9 for Flammable Properties including Flash Point and Flammable (Explosive) Limits

SECTION 6: Accidental release measures

Personal precautions, protective equipment and emergency procedures: This material may burn, but will not ignite readily. Keep all sources of ignition away from spill/release. Stay upwind and away from spill/release. Avoid direct contact with material. For large spillages, notify persons down wind of the spill/release, isolate immediate hazard area and keep unauthorized personnel out. Wear appropriate protective equipment, including respiratory protection, as conditions warrant (see Section 8). See Sections 2 and 7 for additional information on hazards and precautionary measures.

Environmental Precautions: Stop and contain spill/release if it can be done safely. Prevent spilled material from entering sewers, storm drains, other unauthorized drainage systems, and natural waterways. Use water sparingly to minimize environmental contamination and reduce disposal requirements. If spill occurs on water notify appropriate authorities and advise shipping of any hazard. Spills into or upon navigable waters, the contiguous zone, or adjoining shorelines that cause a sheen or discoloration on the surface of the water, may require notification of the National Response Center (phone number 800-424-8802).

Methods and material for containment and cleaning up: Notify relevant authorities in accordance with all applicable regulations. Immediate cleanup of any spill is recommended. Dike far ahead of spill for later recovery or disposal. Absorb spill with inert material such as sand or vermiculite, and place in suitable container for disposal. If spilled on water remove with appropriate methods (e.g. skimming, booms or absorbents). In case of soil contamination, remove contaminated soil for remediation or disposal, in accordance with local regulations.

Recommended measures are based on the most likely spillage scenarios for this material; however local conditions and regulations may influence or limit the choice of appropriate actions to be taken. See Section 13 for information on appropriate disposal.

SECTION 7: Handling and storage

Precautions for safe handling: Keep away from flames and hot surfaces. Wash thoroughly after handling. Use good personal hygiene practices and wear appropriate personal protective equipment (see section 8). Spills will produce very slippery surfaces. High pressure injection of hydrocarbon fuels, hydraulic oils or greases under the skin may have serious consequences even though no symptoms or injury may be apparent. This can happen accidentally when using high pressure equipment such as high pressure grease guns, fuel injection apparatus or from pinhole leaks in tubing of high pressure hydraulic oil equipment.

Do not enter confined spaces such as tanks or pits without following proper entry procedures such as ASTM D-4276 and 29CFR 1910.146. Do not wear contaminated clothing or shoes.

Conditions for safe storage: Keep container(s) tightly closed and properly labeled. Use and store this material in cool, dry, well-ventilated area away from heat and all sources of ignition. Store only in approved containers. Keep away from any incompatible material (see Section 10). Protect container(s) against physical damage.

"Empty" containers retain residue and may be dangerous. Do not pressurize, cut, weld, braze, solder, drill, grind, or expose such containers to heat, flame, sparks, or other sources of ignition. They may explode and cause injury or death. "Empty" drums should be completely drained, properly bunged, and promptly shipped to the supplier or a drum reconditioner. All containers should be disposed of in an environmentally safe manner and in accordance with governmental regulations. Before working on or in tanks which contain or have contained this material, refer to OSHA regulations, ANSI Z49.1, and other references pertaining to cleaning, repairing, welding, or other contemplated operations.

SECTION 8: Exposure controls/personal protection

Chemical Name	ACGIH	OSHA	Phillips 66
Distillates, petroleum, hydrotreated heavy paraffinic	---	---	TWA: 5 mg/m ³ STEL: 10 mg/m ³ as Oil Mist, if Generated

Note: State, local or other agencies or advisory groups may have established more stringent limits. Consult an industrial hygienist or similar professional, or your local agencies, for further information.

Engineering controls: If current ventilation practices are not adequate to maintain airborne concentrations below the established exposure limits, additional engineering controls may be required.

Eye/Face Protection: The use of eye/face protection is not normally required; however, good industrial hygiene practice suggests the use of eye protection that meets or exceeds ANSI Z.87.1 whenever working with chemicals.

Skin/Hand Protection: The use of skin protection is not normally required; however, good industrial hygiene practice suggests the use of gloves or other appropriate skin protection whenever working with chemicals. Suggested protective materials: Nitrile

Respiratory Protection: Where there is potential for airborne exposure above the exposure limit a NIOSH certified air purifying respirator equipped with R or P95 filters may be used.

A respiratory protection program that meets or is equivalent to OSHA 29 CFR 1910.134 and ANSI Z88.2 should be followed whenever workplace conditions warrant a respirator's use. Air purifying respirators provide limited protection and cannot be used in atmospheres that exceed the maximum use concentration (as directed by regulation or the manufacturer's instructions), in oxygen deficient (less than 19.5 percent oxygen) situations, or under conditions that are immediately dangerous to life and health (IDLH).

Suggestions provided in this section for exposure control and specific types of protective equipment are based on readily available information. Users should consult with the specific manufacturer to confirm the performance of their protective equipment. Specific situations may require consultation with industrial hygiene, safety, or engineering professionals.

SECTION 9: Physical and chemical properties

Note: Unless otherwise stated, values are determined at 20°C (68°F) and 760 mm Hg (1 atm). Data represent typical values and are not intended to be specifications.

Appearance: Amber, Transparent

Physical Form: Liquid
1010

Odor: Petroleum

Odor Threshold: No data

pH: Not applicable

Vapor Density (air=1): >1

Upper Explosive Limits (vol % in air): No data

Lower Explosive Limits (vol % in air): No data

Temperature: No data

Evaporation Rate (nBuAc=1): No data

Particle Size: Not applicable

Percent Volatile: No data

Flammability (solid, gas): Not applicable

Solubility in Water: Negligible

Flash Point: > 302 °F / > 150 °C (ASTMD93)

Test Method: Pensky-Martens Closed Cup (PMCC), ASTM D93, EPA

Initial Boiling Point/Range: No data

Vapor Pressure: <1 mm Hg

Partition Coefficient (n-octanol/water) (Kow): No data

Melting/Freezing Point: No data

Auto-ignition Temperature: No

Decomposition

Specific Gravity (water=1): 0.85-0.89 @ 60°F (15.6°C)

Bulk Density: No data

Viscosity: 4.0 - 25 cSt @ 100°C; 21 - 345 cSt @ 40°C

Pour Point: < 10 °F / < -12 °C

SECTION 10: Stability and reactivity

Reactivity: Not chemically reactive.

Chemical stability: Stable under normal ambient and anticipated conditions of use.

Possibility of hazardous reactions: Hazardous reactions not anticipated.

Conditions to avoid: Extended exposure to high temperatures can cause decomposition. Avoid all possible sources of ignition.

Incompatible materials: Avoid contact with strong oxidizing agents and strong reducing agents.

Hazardous decomposition products: Not anticipated under normal conditions of use.

SECTION 11: Toxicological information

Information on Toxicological Effects

Substance / Mixture

Acute Toxicity	Hazard	Additional Information	LC50/LD50 Data
Inhalation	Unlikely to be harmful		>5 mg/L (mist, estimated)
Dermal	Unlikely to be harmful		> 2 g/kg (estimated)
Oral	Unlikely to be harmful		> 5 g/kg (estimated)

Aspiration Hazard: Not expected to be an aspiration hazard.

Skin Corrosion/Irritation: Not expected to be irritating.

Serious Eye Damage/Irritation: Not expected to be irritating.

Skin Sensitization: No information available on the mixture, however none of the components have been classified for skin sensitization (or are below the concentration threshold for classification).

Respiratory Sensitization: No information available.

Specific Target Organ Toxicity (Single Exposure): No information available on the mixture, however none of the components have been classified for target organ toxicity (or are below the concentration threshold for classification).

Specific Target Organ Toxicity (Repeated Exposure): No information available on the mixture, however none of the components have been classified for target organ toxicity (or are below the concentration threshold for classification).

Carcinogenicity: No information available on the mixture, however none of the components have been classified for carcinogenicity (or are below the concentration threshold for classification).

Germ Cell Mutagenicity: No information available on the mixture, however none of the components have been classified for germ cell mutagenicity (or are below the concentration threshold for classification).

Reproductive Toxicity: No information available on the mixture, however none of the components have been classified for reproductive toxicity (or are below the concentration threshold for classification).

Information on Toxicological Effects of Components

Distillates, petroleum, hydrotreated heavy paraffinic

Carcinogenicity: This oil has been highly refined by a variety of processes to reduce aromatics and improve performance characteristics. It meets the IP-346 criteria of less than 3 percent PAH's and is not considered a carcinogen by the International Agency for Research on Cancer.

SECTION 12: Ecological information

GHS Classification: No classified hazards

Toxicity: All acute aquatic toxicity studies on samples of lubricant base oils show acute toxicity values greater than 100 mg/L for invertebrates, algae and fish. These tests were carried out on water accommodated fractions and the results are consistent with the predicted aquatic toxicity of these substances based on their hydrocarbon compositions.

Persistence and Degradability: The hydrocarbons in this material are not readily biodegradable, but since they can be degraded by microorganisms, they are regarded as inherently biodegradable.

Bioaccumulative Potential: Log Kow values measured for the hydrocarbon components of this material are greater than 5.3, and therefore regarded as having the potential to bioaccumulate. In practice, metabolic processes may reduce bioconcentration.

Mobility in Soil: Volatilization to air is not expected to be a significant fate process due to the low vapor pressure of this material. In water, base oils will float and spread over the surface at a rate dependent upon viscosity. There will be significant removal of hydrocarbons from the water by sediment adsorption. In soil and sediment, hydrocarbon components will show low mobility with adsorption to sediments being the predominant physical process. The main fate process is expected to be slow biodegradation of the hydrocarbon constituents in soil and sediment.

Other adverse effects: None anticipated.

SECTION 13: Disposal considerations

The generator of a waste is always responsible for making proper hazardous waste determinations and needs to consider state and local requirements in addition to federal regulations. This material, if discarded as produced, would not be a federally regulated RCRA "listed" hazardous waste and is not believed to exhibit characteristics of hazardous waste. See Sections 7 and 8 for information on handling, storage and personal protection and Section 9 for physical/chemical properties. It is possible that the material as produced contains constituents which are not required to be listed in the SDS but could affect the hazardous waste determination. Additionally, use which results in chemical or physical change of this material could subject it to regulation as a hazardous waste. This material under most intended uses would become "Used Oil" due to contamination by physical or chemical impurities. Whenever possible, Recycle used oil in accordance with applicable federal and state or local regulations. Container contents should be completely used and containers should be emptied prior to discard.

SECTION 14: Transport information

U.S. Department of Transportation

(DOT) UN Number: Not regulated

UN proper shipping name: None

Transport hazard class(es): None

Packing Group: None

Environmental Hazards: This product does not meet the DOT/UN/IMDG/IMO criteria of a marine pollutant

Special precautions for user: If shipped by land in a packaging having a capacity of 3,500 gallons or more, the provisions of

49 CFR, Part 130 apply. (Contains oil)

Transport in bulk according to Annex II of MARPOL 73/78 and the IBC Code: Not applicable

SECTION 15: Regulatory information

CERCLA/SARA - Section 302 Extremely Hazardous Substances and TPQs (in pounds):

This material does not contain any chemicals subject to the reporting requirements of SARA 302 and 40 CFR 372.

CERCLA/SARA - Section 311/312 (Title III Hazard

Categories) Acute Health Hazard: No
Chronic Health Hazard: No
Fire Hazard: No
Pressure Hazard: No
Reactive Hazard: No

CERCLA/SARA - Section 313 and 40 CFR 372:

This material does not contain any chemicals subject to the reporting requirements of SARA 313 and 40 CFR 372.

EPA (CERCLA) Reportable Quantity (in pounds):

This material does not contain any chemicals with CERCLA Reportable Quantities.

California Proposition 65:

This material does not contain any chemicals which are known to the State of California to cause cancer, birth defects or other reproductive harm at concentrations that trigger the warning requirements of California Proposition 65.

International Hazard Classification

Canada:

This product has been classified in accordance with the hazard criteria of the Hazardous Products Regulations (SOR/2015-17) and the SDS contains all the information required by the Regulations.

International Inventories

All components are either listed on the US TSCA Inventory, or are not regulated under TSCA. All components are either on the DSL, or are exempt from DSL listing requirements.

U.S. Export Control Classification Number: EAR99

SECTION 16: Other information

Issue Date:	Previous Issue Date:	SDS Number	Status:
28-Jun-2016	23-Jun-2016	LBPH814637	FINAL

Revised Sections or Basis for Revision: New SDS

Guide to Abbreviations:

ACGIH = American Conference of Governmental Industrial Hygienists; CASRN = Chemical Abstracts Service Registry Number; CEILING = Ceiling Limit (15 minutes); CERCLA = The Comprehensive Environmental Response, Compensation, and Liability Act; EPA = Environmental Protection Agency; GHS = Globally Harmonized System; IARC = International Agency for Research on Cancer; INSHT = National Institute for Health and Safety at Work; IOPC = International Oil Pollution Compensation; LEL = Lower Explosive Limit; NE = Not Established; NFPA = National Fire Protection Association; NTP = National Toxicology Program; OSHA = Occupational Safety and Health Administration; PEL = Permissible Exposure Limit (OSHA); SARA = Superfund Amendments and Reauthorization Act; STEL = Short Term Exposure Limit (15 minutes); TLV = Threshold Limit Value (ACGIH); TWA = Time Weighted Average (8 hours); UEL = Upper Explosive Limit; WHMIS = Worker Hazardous Materials Information System (Canada)

Disclaimer of Expressed and implied Warranties:

The information presented in this Safety Data Sheet is based on data believed to be accurate as of the date this Safety Data Sheet was prepared. HOWEVER, NO WARRANTY OF MERCHANTABILITY, FITNESS FOR ANY PARTICULAR PURPOSE, OR ANY OTHER WARRANTY IS EXPRESSED OR IS TO BE IMPLIED REGARDING THE ACCURACY OR COMPLETENESS OF THE INFORMATION PROVIDED ABOVE, THE RESULTS TO BE OBTAINED FROM THE USE OF THIS INFORMATION OR THE PRODUCT, THE SAFETY OF THIS PRODUCT, OR THE HAZARDS RELATED TO ITS USE. No responsibility is assumed for any damage or injury resulting from abnormal use or from any failure to adhere to recommended practices. The information provided above, and the product, are furnished on the condition that the person receiving them shall make their own determination as to the suitability of the product for their particular purpose and on the condition that they assume the risk of their use. In addition, no authorization is given nor implied to practice any patented invention without a license.

TABLE OF CONTENTS

	PAGE
SPECIFICATIONS & OPERATING DESCRIPTION	10
OPERATION DIAGRAM.....	12
<u>SECTION I</u> PRELIMINARY INFORMATION	14
<u>SECTION II</u> SAFETY.....	15
<u>SECTION III</u> HYDRAULIC FLUID.....	16
<u>SECTION IV</u> PUMP SET-UP	17
<u>SECTION V</u> OPERATION	20
<u>SECTION VI</u> BLEEDING AIR FROM YOUR SYSTEM.....	22
<u>SECTION VII</u> MAINTENANCE.....	23
<u>SECTION VIII</u> TROUBLESHOOTING.....	24
<u>SECTION IX</u> PARTS BREAKDOWN AND DIAGRAMS.....	25

Air Over Oil Pump Specifications and Operating Description

Air Over Oil Pump	
Maximum working pressure	350 BAR
Maximum air pressure	5.8 BAR
Air connection	¼" NPT
Oil connection	1/4 BSPP PORT
Maximum weight without oil	4.65 kg
Reservoir capacity / usable capacity in horizontal position	2.4 / 2.1 liter
Reservoir capacity / usable capacity in vertical position	2.2 / 1.5 liter
Noise level	75 dB (A)

The device supplied is an air-powered pump that converts a compressed air supply into a pressurized hydraulic flow. Model 45-5820-01 utilizes a D03 subplate for use with double acting hydraulic actuators. Model 45-5820-02 uses a foot treadle for single acting hydraulic actuators.

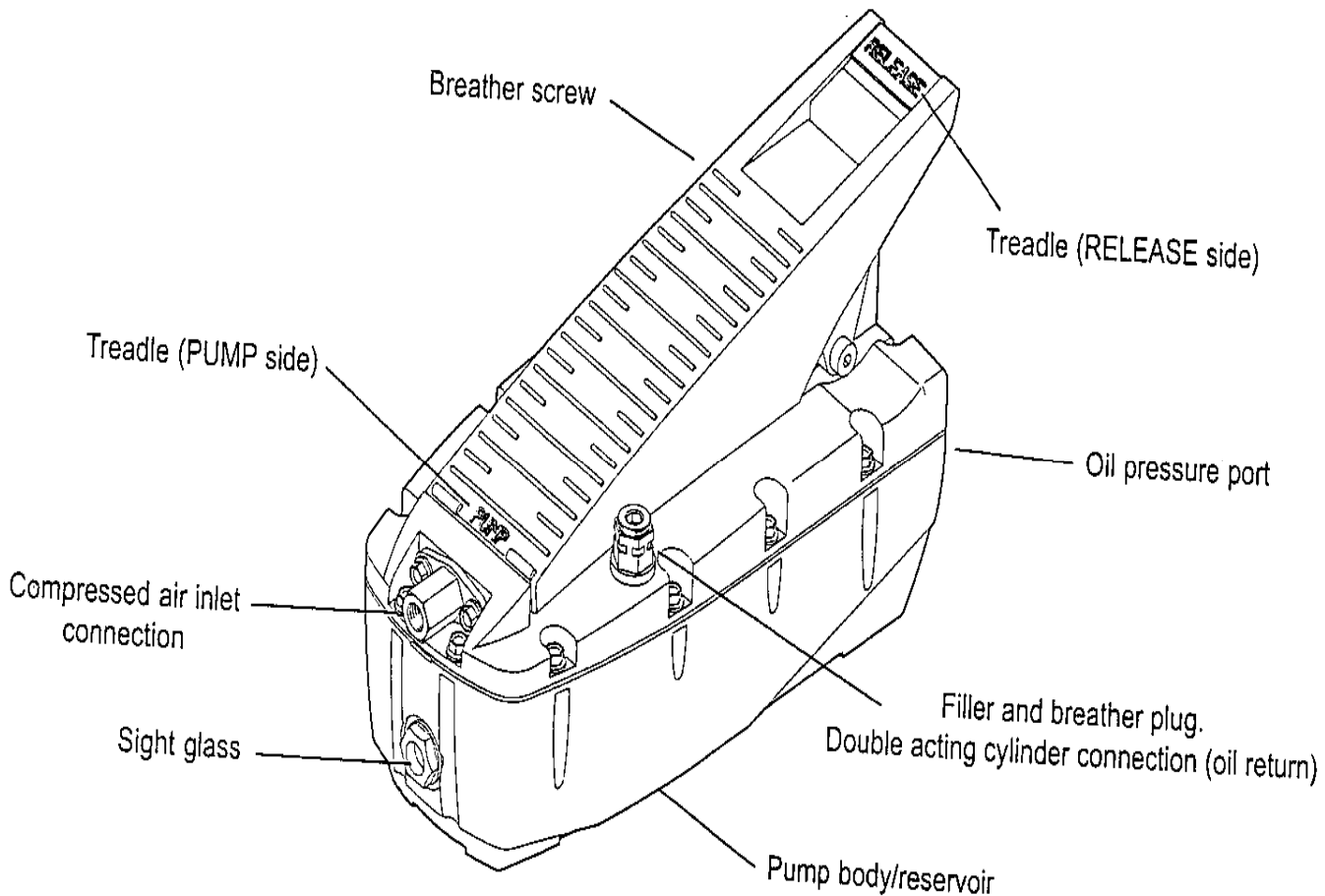

Pump 45-5820-02

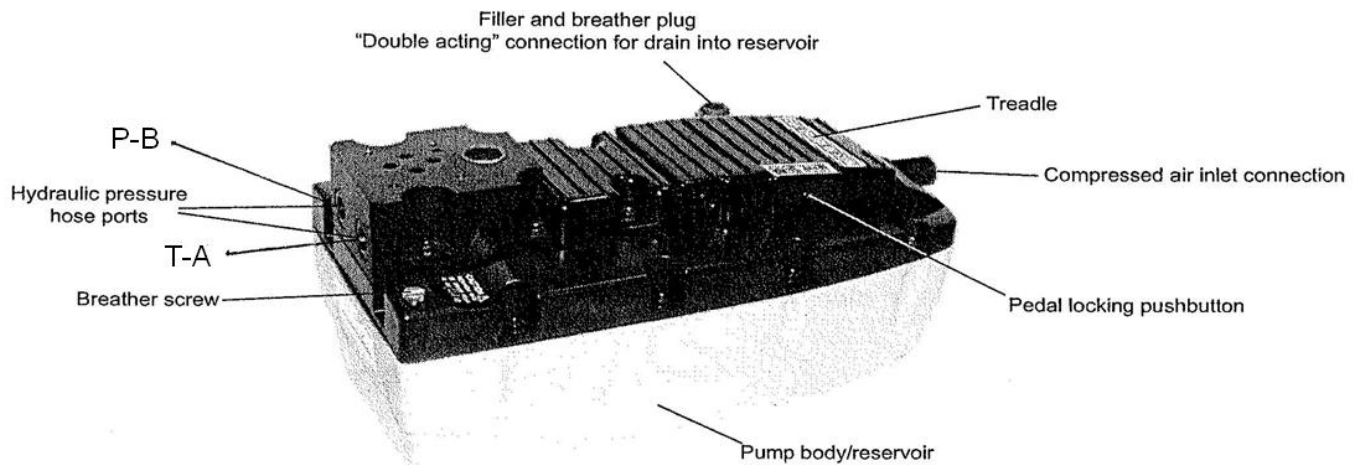

SAE 4 "P" Port as shipped with cross-over plate or "B" port with pump mounted valve.
 SAE 4 "T" Port as shipped with cross-over plate or "A" port with pump mounted valve.

Figure 1

Pump 45-5820-01

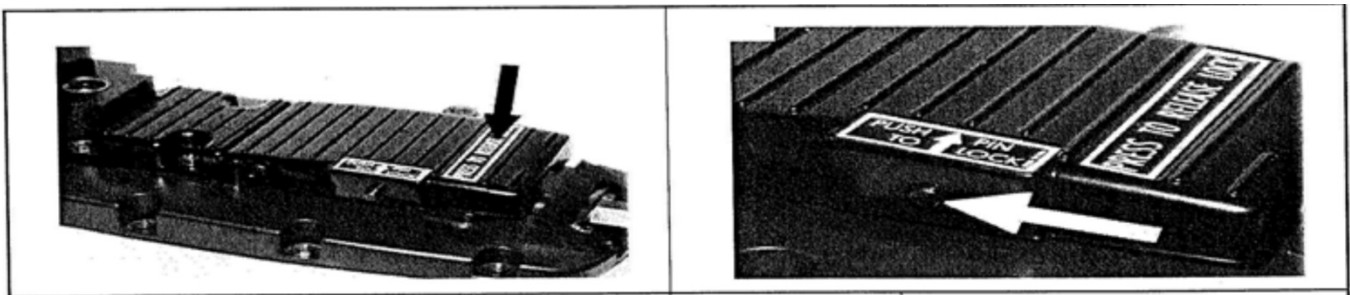

Figure 2

Figure 3

Pump 45-5820-01

OPERATION DIAGRAM

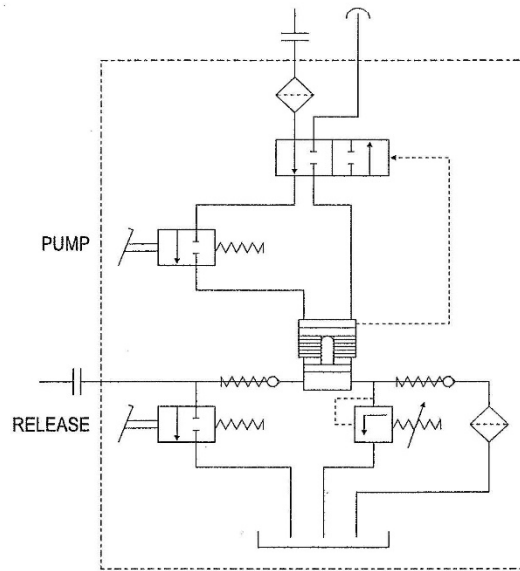

Figure 4

Pump 45-5820-02

OPERATION DIAGRAM

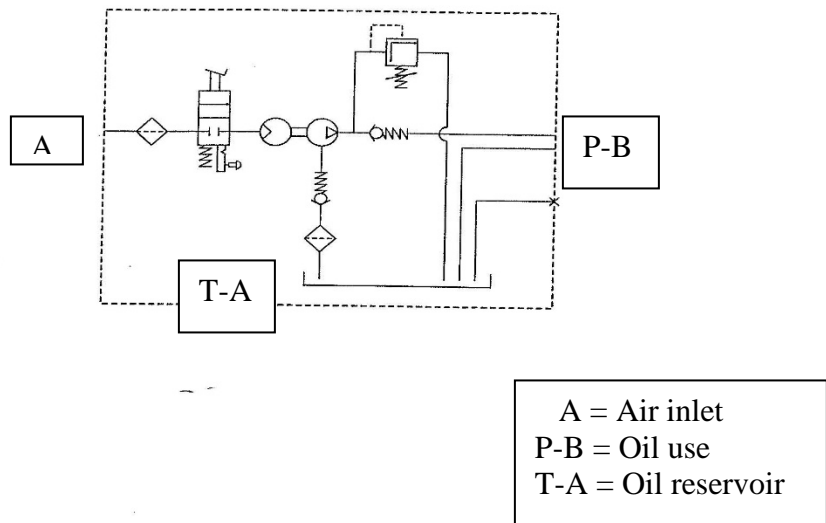

Figure 5

Pump 45-5820-01

SECTION I

PRELIMINARY INFORMATION

Most malfunctions in new equipment are the result of improper operation and/or improper set-up and assembly. Please read the following information.

Remove pump from shipping container...but DO NOT remove any plugs or valves until the unit is ready to be fully assembled to prevent dirt or foreign matter from contaminating system or oil.

Visually inspect all components for shipping damage. If any damage is found, notify carrier immediately and contact the factory.

Use only cylinders, hoses and equipment rated for 350 BAR operating pressure. Use of cylinders or other components rated for less than 350 BAR may result in system failure, which may result in bodily injury or property damage.

If the pump is set aside to be used some time after purchasing, it must be stored in a place adequately protected against weather conditions at a temperature between 10° and 49°C.

Do not stack more than four single boxes containing pumps. If the pumps are delivered packed on pallets, they should be left in their original packing and unpacked immediately prior to use.

SPARE PARTS

When ordering spare parts, always provide the following:

- 1) Part number
- 2) Part description
- 3) Pump type
- 4) Serial number

... ..

SECTION II

SAFETY

WORKING PRESSURE

 **Warning:** The pump's maximum working pressure is 350 BAR. Make sure that all hydraulic equipment used with this pump, such as cylinders, hoses, and fittings, are rated at 350 BAR operating pressure. Use of cylinders or other components rated for less than 350 BAR may result in system failure which may result in bodily injury or property damage.

HYDRAULIC CONNECTIONS

When making connections with quick disconnect couplings, make certain the couplings are fully engaged. Never disconnect or connect any hydraulic hoses or fittings without first turning off the pump, then shifting or opening all hydraulic controls several times to ensure that the system has been completely depressurized. Check gauge to verify that pressure has been released. Threaded connections such as fittings, gauges, etc., must be securely tightened and leak free. Loose or improperly threaded fittings can be potentially dangerous if pressurized. Never grab, touch, or in any way come into contact with a hydraulic pressure leak.

 **WARNING: FAILURE TO FOLLOW THIS WARNING MAY RESULT IN ESCAPING OIL PENETRATING THE SKIN AND CAUSE SERIOUS INJURY.**

OPERATING SAFELY

Keep your operators thinking. With pump installed and in production, set and enforce work rules that help avoid human injury and damage to equipment. Make certain every operator is properly trained in all phases of equipment operation and develops good work habits. Always ensure valves are in the correct position before starting a hydraulic pump.

Keep the pump well clear of heat sources, open flames and sparks. Maximum operating temperature of the pump is 49°C. The pump must be set into operation exclusively using feet. It is potentially dangerous to operate the pump with any other part of the body. Do not attempt to operate the pump by standing on the treadle, use only light foot pressure to operate the pump mechanism.

If the pump is set aside to be used some time after purchasing, it must be stored in a place adequately protected against weather conditions at a temperature between 10° and 49°C. Do not stack more than four single boxes containing pumps. If the pumps are delivered packed on pallets, they should be left in their original packing and unpacked immediately prior to use.

SECTION III

HYDRAULIC FLUID

VektorFlo · hydraulic oil, p/n 65-0010-01 3.8 liter (1 gallon), is recommended for all Vektek pumps operating in ambient temperatures above -15°C (5°F).

VektorFlo · hydraulic oil is a premium grade petroleum based fluid with detergent and antiwear additives. VektorFlo · hydraulic oil also includes additives to inhibit corrosion, rust, oxidation, and foaming.

VektorFlo · Hydraulic Oil Characteristics:

Pour Point.....	< -15°C (5°F)
Flash Point.....	>150°C (302°F).....(PMCC)
Viscosity	22-320 cSt @ 40°C (104°F)
.....	4-24 cSt @ 100°C (212°F)
ISO Viscosity Grade.....	32

You may also substitute other brands of oil rated at ISO grade 32. Vektek recommends completely draining existing oil before any substitution is made.

Use of hydraulic oil with a viscosity grade higher than ISO 32 may cause sluggish return action of single acting devices and should therefore, only be used on double acting systems. ISO grade 46 is compatible with Vektek pumps and may be used if deemed necessary.

MSDS sheet on page 3.

SECTION IV

PUMP SET-UP

This chapter describes the methods of installation of the pump. The method here recommended will give excellent results. The purchaser of the pump, i.e. the manufacturer of the machine on which the pump will be installed, may opt for different types of installation, using brackets or any types of accessories considered to be necessary. **HOWEVER, THE ORIGINAL SHAPE AND ATTACHMENT OF THE PUMP MUST NOT BE MODIFIED, THE PROTECTIONS APPLIED TO THE PUMP MUST NOT BE TAMPERED WITH AND NO ACTION MUST BE TAKEN THAT COULD MAKE THE PUMP POTENTIALLY DANGEROUS.** If these instructions are disregarded, the person who is responsible for the modifications automatically assumes full liability for any accidents that may occur during use of the pump.

Pump models 45-5820-01 and 45-5820-02 can be installed in a horizontal or vertical position.

Figure 6 shows the drilling hole location for designing the pump baseplate. The pump can be anchored to the baseplate using four #8 or M5 thread forming screws.

IMPORTANT: On pump models 45-5820-01 and 45-5820-02, fixing hole depth is 19 mm engaged into pump reservoir. The effective length of the fixing screw threads must not exceed this dimension.

FILLING THE RESERVOIR (IF THE PUMP IS SUPPLIED WITHOUT OIL)

The oil quantities required to fill the pump reservoir in relation to the mounting position are shown on specification page, together with the relative usable capacities.

Use the oil types specified or equivalent products. The use of oil with different characteristics can result in serious damage to the pump and render it unsuitable for use. **THE MANUFACTURER SHALL NOT BE HELD RESPONSIBLE FOR INJURY TO PEOPLE OR DAMAGE TO PROPERTY CAUSED BY THE USE OF UNSUITABLE OR EXHAUST OIL. DAMAGE TO THE PUMP RESULTING FROM THE ABOVE MENTIONED CAUSES IS NOT COVERED BY WARRANTY.**

FILLING THE RESERVOIR

- Use a slotted tip screwdriver to remove the filler plug.
- Pour the correct quantity of oil into the reservoir.
- Clean the edges of the filler opening with a clean cloth and refit the plug, pressing it down fully.

Start-up

- Connect the hydraulic pressure hose. The hose must be fitted with a 1/4 bspp fitting.
- Unscrew the breather screw by one or two turns using an appropriate screwdriver.

SECTION IV

PUMP SET-UP (CONTINUED)

Connecting the oil return line (use with a double acting cylinder)



WARNING: The operations described below must be carried out with the pump in a horizontal position. The pump can be mounted vertically only when the operations are concluded. This will prevent oil leaking from the reservoir.

- If the breather plug is in its extracted position, press it fully into its down position.
- Unscrew the threaded insert from the center of the breather plug and connect a hose with a 1/4" NPT fitting after binding the thread with Teflon tape. Mount the other end of the hose above the reservoir.

Connecting the compressed air line

- Select a quick coupler that is suitable for your air line, bind the thread with Teflon tape, and then screw it into the compressed air inlet connection.

Teflon is a registered trademark of Dupont Dow Elastomers®.

Figure 6

NOTE: Diagram is **NOT** to scale.

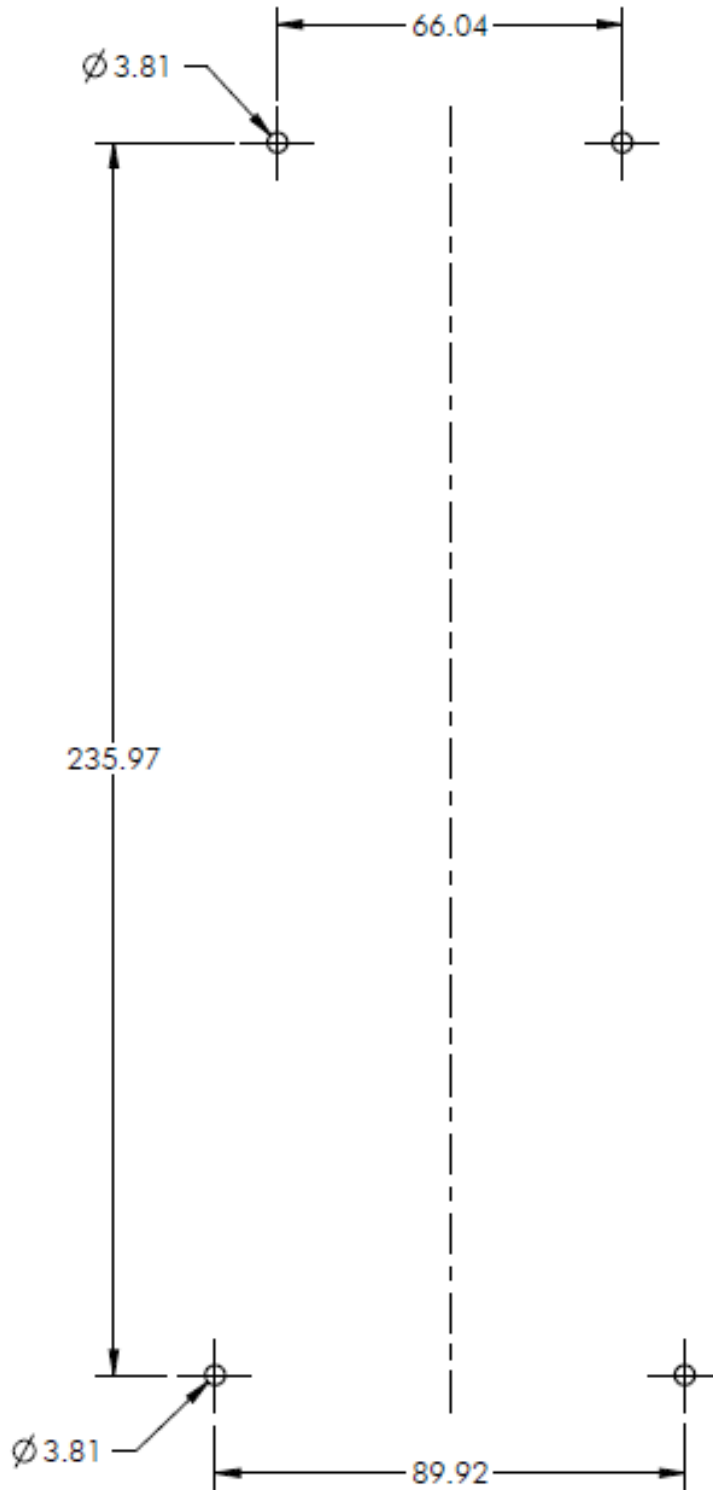

SECTION V

OPERATION

Model 45-5820-02 pump is extremely simple to use:

- To activate the pump, press gently down with your foot on the end of the treadle marked "PUMP". The pump will start to deliver pressurized oil and thereby cause the connected machine to operate.
- When the treadle is released, i.e. when you remove your foot, the pump stops but the pressure is maintained on the oil side so that the connected machine cylinder holds the load in the position it has reached.
- To return the pressure to zero and hence retract the machine cylinder to its starting position, press the treadle in the area marked "RELEASE."

WARNING: Immediately after the pump has been installed the circuit may contain air locks which prevent pressurization. If the pump is unable to pressurize the oil circuit, proceed as described below.

THE FOLLOWING OPERATIONS ARE THE ONLY ACTIONS WHICH CAN BE MADE ON THE PUMP USING THE HANDS. IN NORMAL CIRCUMSTANCES THE PUMP MUST BE OPERATED EXCLUSIVELY WITH THE FEET.

- If the pump is mounted vertically, disassemble it and place it in a horizontal position on the floor.
- Lift the treadle at the "PUMP" side. There is a flat pushbutton beneath the treadle.
- Use one hand to press the "RELEASE" side of the treadle while pressing the pushbutton under the "PUMP" side with your other hand. Maintain the pressure on the "RELEASE" side and the "PUMP" pushbutton for about 15 seconds.

The pump should now work correctly. If you still have problems, repeat the above mentioned procedure.

Model 45-5820-01 utilizes a D03 mounting pattern subplate:

Using the treadle

The pump can be used for either continuous or intermittent duty:

- **Intermittent duty:** press and release the treadle to start and stop the pump (figure 2).
- **Continuous duty:** press the treadle (figure 2) then push in the locking pin (figure 3) to lock the treadle control in the “on” position.

The pump will now start working, the operating mode depending on the type of actuator installed. Press the treadle firmly to release the pin and stop the oil flow.

Using the controls

The 45-5820-01 model can be connected to a 4/3 or 4/2 directional control valve with a D03 mounting pattern connection that can be used to operate a double acting hydraulic cylinder.

- With the **4/3** valve, the pump operates in three positions:
 - Position 1:** the oil is sent to port “T” and returns to the reservoir via port “P” (figure 1).
 - Position 2:** locked position, ports “P” and “T” are closed and the oil flow is returned directly to the reservoir.
 - Position 3:** the oil is sent to port “P” and returns to the reservoir via port “T”
- With the **4/2** valve, the pump operates in two positions:
 - Position 1:** the oil is sent to port “T” and returns to the reservoir via port “P” (figure 1).
 - Position 2:** the oil is sent to port “P” and returns to the reservoir via port “T”

For instructions on connecting the valve with a D03 mounting pattern correctly, refer to the documentation supplied with the valve itself.

NOTE: to use this model with a single acting cylinder, close port “T” with a SAE 4 plug 30-6011-44.

WARNING: immediately after the pump installation, the circuit may contain air locks that prevent pressurization. If the pump is unable to pressurize the oil circuit, proceed as described below. If the pump is mounted vertically, disassemble it and place it in a horizontal position on the floor.

Priming the pump

With the **4/3** directional control valve:

- Press the pump treadle and position the valve, i.e. position two for about 15 seconds.
- Connect to a cylinder and check that the pump is primed. If the cylinder does not move repeat the operation.

With the **4/2** directional control valve:

- Using a suitable pressure hose, connect the pressurized oil delivery port to the drain side and press the treadle for about 15 seconds.
- Connect to a cylinder and check that the pump is primed. Repeat the operation if the cylinder does not move.

SECTION VI

BLEEDING AIR FROM YOUR SYSTEM

Bleeding air from any hydraulic system can be a tedious task. The following suggestions should help expedite the procedure.

Air naturally moves toward the highest point in the system or device. Elevating the pump to a height greater than the fixture devices and cycling the control valve several times will usually evacuate most of the air. The air bubbles will try to seek the highest point in the circuit and be released into the pump reservoir, which is capable of dispersing them.

If a particular system proves difficult to bleed using the above method, turn the pump on, move the valve handle to the advance/clamp position, and carefully “crack” a fitting nut loose at the device. (Usually only ½-¾ full turn of the nut is required to allow air/oil to escape from the connection.) The appearance of “milky” colored oil from this joint indicates that air is being evacuated. While still under pressure, re-tighten the connection before turning off the pump to prevent re-entry of air back into the system. Turn the pump off, re-check and re-tighten the fitting, as required, before proceeding to the next fitting.

Sluggish or “jerky” device action is usually the first sign of air in a hydraulic system. Accordingly, removal of as much air as possible by the methods described above will help your system function smoothly.

SECTION VII

MAINTENANCE

The routine maintenance work described below must be performed exclusively by a skilled technician who has a thorough knowledge of the pump and its operation and who has read this manual completely. Maintenance must be carried out with maximum caution to avoid possible accidents. This chapter describes the only maintenance procedures permitted. **Execution of unauthorized maintenance work will automatically invalidate warranty and free the manufacturer from all liability.**

Checking connections

- Check the hydraulic and pneumatic connections once a week. Ensure that the connections on the pump are screwed down tightly and show no signs of breakage, cracks or other damage. Ensure that the hoses are not damaged in any way (cuts, abrasion, cracks, etc.).

Cleaning the air filter

There is an air filter inside the air inlet connection.

- Use a slotted tip screwdriver of the appropriate size to unscrew the filter from the inlet connection until it is extracted.
- Clean the filter with compressed air and then refit and screw it into position. Do not over-tighten the filter or damage may ensue.
- Reconnect the air line quick coupler after binding the thread with Teflon tape.

If the air filter is excessively contaminated or damaged, it must be renewed. Order a new filter from the manufacturer, referring to the list of spare parts at the end of this manual.

Checking the hydraulic oil

Periodically check that the pump contains the correct quantity of hydraulic oil by checking the level on the sight glass. If the level is below minimum, top off with the specified hydraulic oil.

Hydraulic oil change

Change the oil at intervals of 250 duty hours. This operation must be performed when the cylinder is fully retracted:

- If the pump is mounted vertically, disassemble it and position it horizontally.
- Use a slotted tip screwdriver to remove the filler plug. (Page 1)
- Empty the pump of oil by turning it upside down over a suitable container.
- Allow all the oil to flow into the container and then fill the pump with the quantity and type of new oil specified on page 5.
- Clean the filler opening with a clean cloth and refit the plug, pressing it fully down or in the partially-inserted breather position (depending on the application).

SECTION VIII TROUBLE SHOOTING

The following chart describes the main problems that could occur during operation of the pump, together with an indication of the appropriate corrective action. If the prescribed action fails to solve the problem, ask the manufacturer.

PROBLEM	POSSIBLE CAUSE	CORRECTIVE ACTION
Pump cannot be started	Compressed air line closed	Check compressed air supply to pump
Pump stops working under load	Insufficient air pressure	Check compressed air supply to pump is sufficient to generate 350 bar outlet hydraulic pressure
	Air filter dirty or clogged	Clean or renew
Pump operates but no pressurized oil is delivered	Oil leak in the main hydraulic circuit	Check the circuit for leaks and repair as necessary
	Pump internal leak	Check for leaks and return pump to manufacturer for repair
	Low oil level	Check level and top up as necessary
Pump fails to reach maximum pressure	Insufficient air pressure	Check compressed air supply to pump is sufficient to operate pump
	Internal relief valve incorrectly set	Ask the manufacturer
	Oil leak in the main hydraulic circuit	Check the circuit for leaks and repair as necessary
Pump delivers pressurized oil but load is not lifted	Excess load	Reduce
	Oil circulation fault	Check if pipe lines are obstructed or if cylinder is working correctly
Piston retracts although treadle is not pressed on RELEASE side	Oil leak in the main hydraulic circuit Pump internal fault	Check the circuit for leaks and repair as necessary Check if pipelines are obstructed or if cylinder is working correctly. If pump still malfunctioning, return pump to manufacturer for repair
Piston fails to perform retract stroke (single acting cylinder)	Oil pressure line obstructed or coupling incorrectly connected	Check oil pressure line
	If piston is designed to return under gravity, ensure load is sufficient	Increase load on cylinder
	Cylinder spring broken	Repair
	Cylinder release valve not functioning	Repair cylinder
Piston fails to perform retract stroke (double acting cylinder)	Oil pressure line obstructed or coupling incorrectly connected	Check oil pressure line
	Cylinder release valve not working	Repair cylinder
Pump flow rate insufficient	Insufficient air pressure	Check compressed air supply to pump is sufficient to generate 350 bar outlet hydraulic pressure
	Air filter dirty or clogged	Clean or renew
	Reservoir breather plug or screw not opened	Open breather plug or screw as described in Section V

- - - - -

SECTION IX

PARTS BREAKDOWN AND DIAGRAMS

Figure 4
Pump 45-5820-02

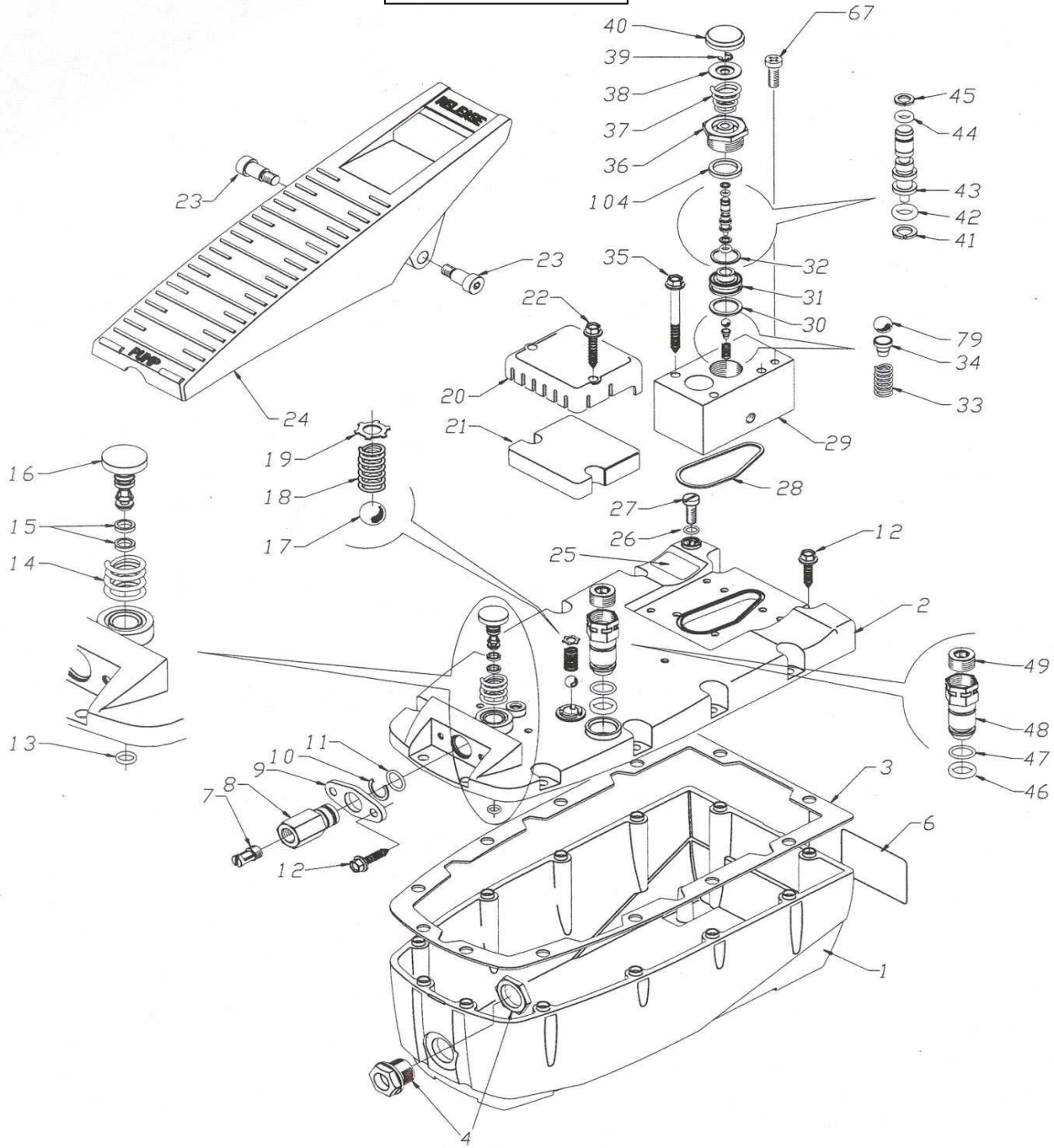

**LIST OF SPARE PARTS
FOR FIGURES 4 AND 5**

KEY DESCRIPTION	Part Number	KEY DESCRIPTION	Part Number
1 Reservoir 45-5820-01, -02	309310030	26 O-ring * & ** (1)	425830011
2 Cover	182840010	27 Screw	426321170
3 Cover Seal * & ** (1)	139220110	28 Cover adjusting block seal * & ** (1)	425830045
4 Oil Level	301100020	29 Drive adjusting block	142100080
6 Model # decal 45-5820-01	67040060	30 Copper washer * & ** (1)	451435045
6 Model # decal 45-5820-02	67040061	31 Release valve seat	172150150
7 Air filter * & ** (1)	139110010	32 Copper washer * & ** (1)	451435038
8 Swivel coupler	128690070	33 Spring	151050330
9 Swivel coupler flange	147010010	34 Ball guide spring	150060060
10 Retaining ring	427270140	35 Thread-forming screw	426446406
11 O-ring * & ** (2)	425830021	36 Release guide	131050080
12 Thread-forming screw	426446355	37 Spring	151100030
13 O-ring * & ** (1)	425831074	38 Spring washer 45-5820-01,-02	141500130
14 Beginning cycle pin spring	151050300	39 Retaining ring	427180050
15 Quad-ring * & ** (2)	425880020	40 Plunger cover	182880020
16 Pin	102130090	41 Back-up ring * & ** (1)	425784018
17 Quad-ball	428630070	42 O-ring * & ** (1)	425830009
18 Relief valve spring	151050320	43 Plunger	102150020
19 Cogged retaining ring	427260040	44 O-ring * & ** (1)	425830007
20 Foam tube cover	182840020	45 Back-up-ring * & ** (1)	425784014
21 Foam tube	139220120	46 O-ring * & ** (1)	425820086
22 Thread-forming screw	426446385	47 O-ring * & ** (1)	425830024
23 Foot pedal attachment screw	196020030	48 Filter plug	128690050
24 Foot pedal 45-5820-02	171000040	49 Taper plug	426620250
25 Reservoir ventilation label	193515053	67 Screw	426310137
		79 Ball	428620042
		104 P.T.F.E. ring	141440010

* INCLUDED IN SEAL KIT 800050090 FOR PUMP 45-5820-01

** INCLUDED IN SEAL KIT 800050140 FOR PUMP 45-5820-02

- - - - -

SECTION IX
PARTS BREAKDOWN AND DIAGRAMS (CONTINUED)
Figure 4 (Continued)

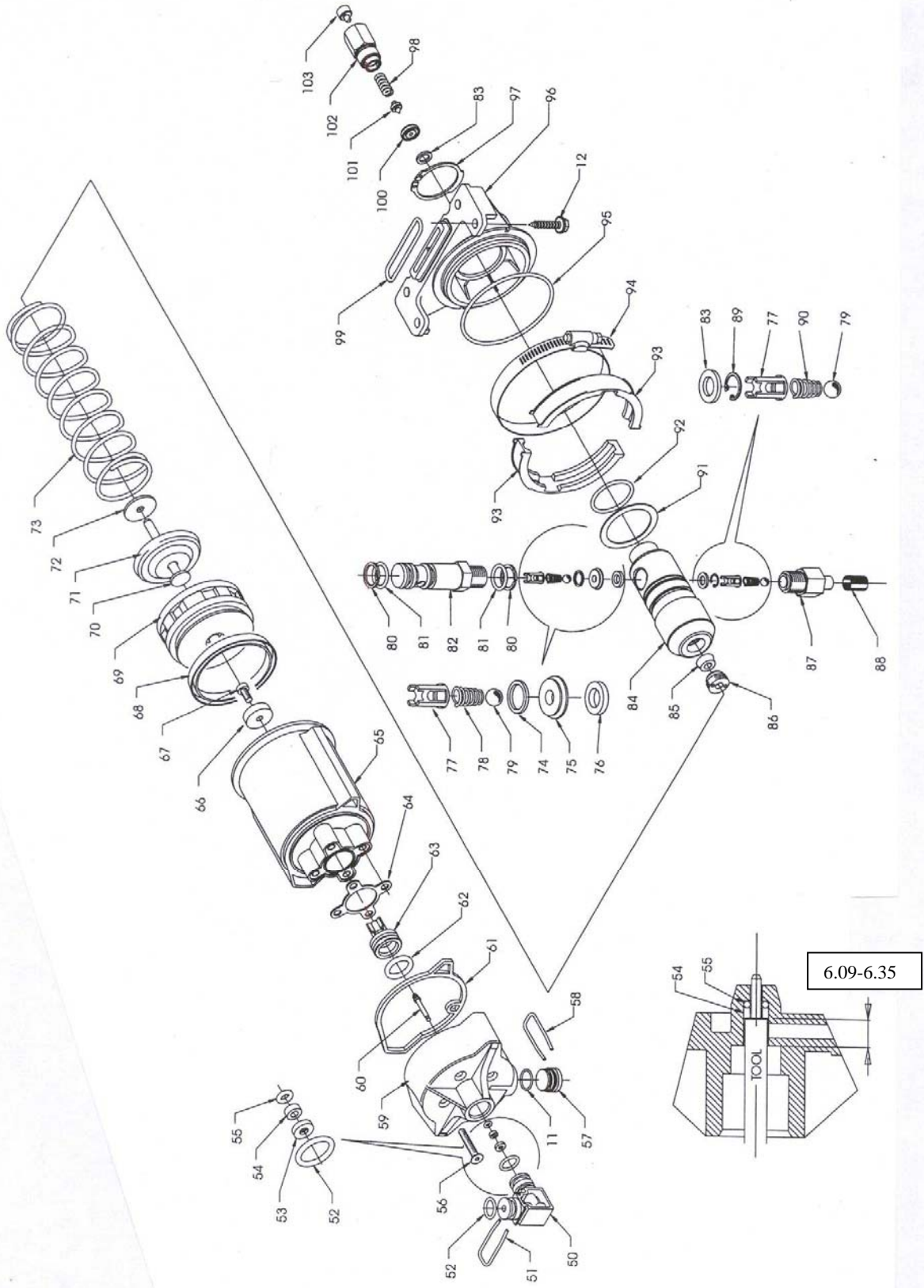

PARTS BREAKDOWN AND DIAGRAMS (CONTINUED)

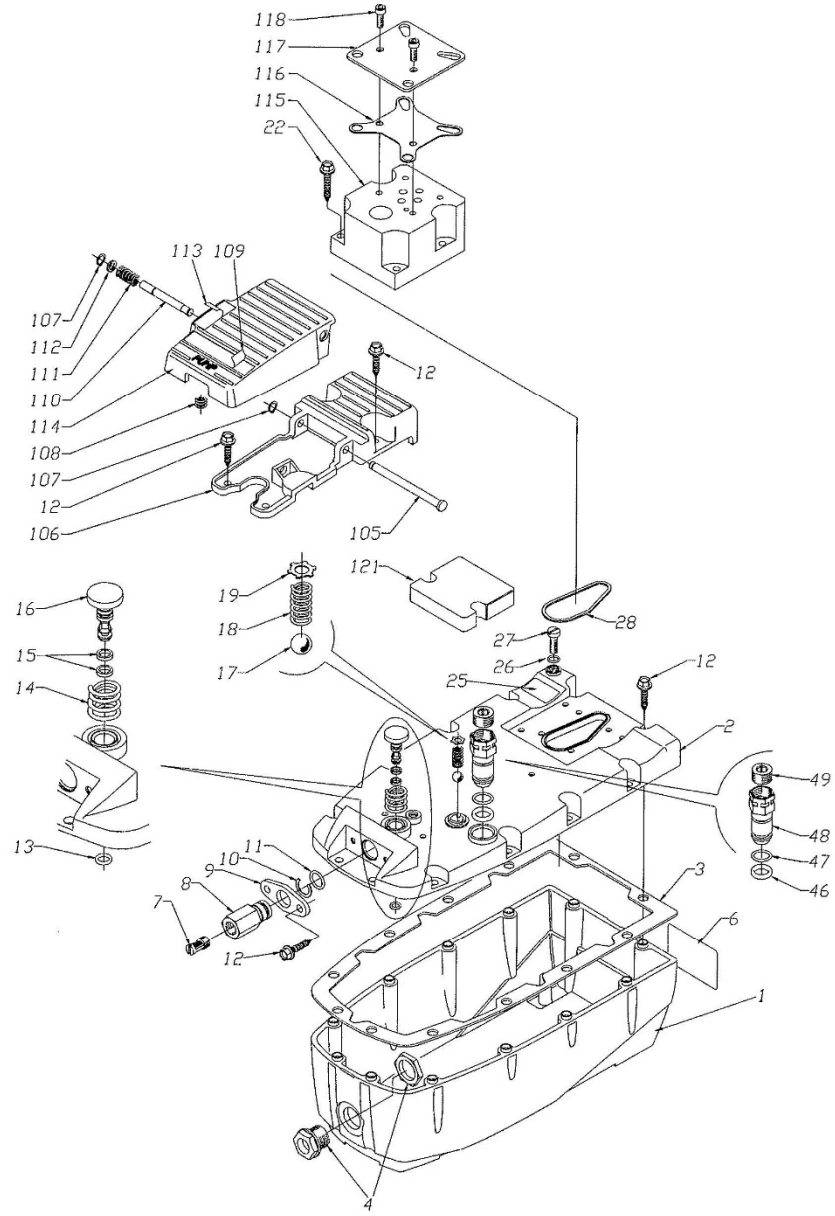

FIGURE 5
Pump 45-5820-01

**LIST OF SPARE PARTS
FOR FIGURE 4 AND 5**

KEY DESCRIPTION	Part Number	KEY DESCRIPTION	Part Number
11 O-ring	425830021	78 Spring	151100090
12 Thread-forming screw	426446355	79 Ball	428620042
50 Cover-head adapter	309040010	80 Back-up ring * & ** (2)	425784034
51 Locking adapter staple	141070010	81 O-ring * & ** (2)	425837022
52 O-ring * & ** (2)	425830084	82 Plunger	102040030
53 Seal * & ** (1)	139200010	83 Copper washer * & ** (2)	451435006
54 Bushing	116010010	84 Body 55-8213-01	131050090
55 O-ring * & ** (1)	425830006	84 Body 55-8213-00	131050100
56 Screw M5x0.8x25	426116057	85 Seal * & ** (1) 55-8213-01	425000021
57 Head plug	182050030	85 Seal 55-8213-00	425000070
58 Locking head staple	141070020	86 Piston guide head 55-8213-01	184000030
59 Head	184000060	86 Piston guide head 55-8213-00	184000050
60 Plunger	102170010	87 Suction filter adapter	128510021
61 Seal * & ** (1)	139200050	88 Oil filter	139000010
62 U Cup * & ** (1)	425121044	89 Retaining ring	427160090
63 Piston	160900020	90 Spring	151100100
64 Seal * & ** (1)	139220090	91 Spring seat washer	141500110
65 Cylinder	309000020	92 O-ring * & ** (1)	425830108
66 Washer seal * & ** (1)	141480030	93 Strap support	177000030
67 Screw	426310137	94 Standard pipe clamp	427102100
68 Seal * & ** (1)	425620210	95 O-ring * & ** (1)	425830136
69 Piston	160900010	96 Cover	147130020
70 Piston 45-5820-02	160900040	97 Retaining ring	427150350
70 Piston 45-5820-01	160900060	98 Peak valve spring	151050030
71 Spring washer 45-5820-02	141500120	99 Seal * & ** (1)	425000110
71 Spring washer 45-5820-01	141500150		
72 Bumper	139220030	100 Valve seat	172150030
73 Spring	151050310	101 Spear valve	182260010
74 Copper washer * & ** (1)	451430007	102 Peak valve adapter	128630040
75 Feed pin seat	172150040	103 Peak valve spring	141400070
76 Copper washer * & ** (1)	451436006	104 P.T.F. ring	141440010
77 Ball guide	150050020		

* INCLUDED IN SEAL KIT 800050090 FOR PUMP 45-5820-01

** INCLUDED IN SEAL KIT 800050140 FOR PUMP 45-5820-02

LIST OF SPARE PARTS

KEY DESCRIPTION		Part Number
105	Connecting pin	141210110
106	Lower treadle	171000050
107	Retaining ring	427270060
108	Treadle spring	151050140
109	Release label	193517055
110	Locking pin	141210100
111	Locking spring	151050350
112	Washer	426826020
113	Locking label	193517054
114	Upper treadle	171000051
115	Block	142100090
116	Seal-upc (NOT USED)	139220130
117	Cross-over plate	93-1989-00
118	Screw M5 X 0.8 X 25	21-5000-20
118A	Screw M5 X 0.8 X 30	21-5000-23
118B	Screw M5 X 0.8 X 45	21-5000-13
118C	Screw M5 X 0.8 X 60	21-5000-30
119	Adapter SAE 6 Female X SAE 4 Male	30-8012-46
120	Pipe nipple	50-6030-01
121	Air regulator	95-0421-01
	Seal kit for 45-5820-01	800050090
	Seal kit for 45-5820-02	800050140

**Items 105 thru 118 are for pump 45-5820-01 only
Items 118A thru 121 not shown**