

APPLY LUBRICANT TO ALL SEALS
PRIOR TO INSTALLATION.
DO NOT USE SILICONE TYPE LUBRICANTS.
FOR PROPER ARM MOUNTING SEE IS1505.

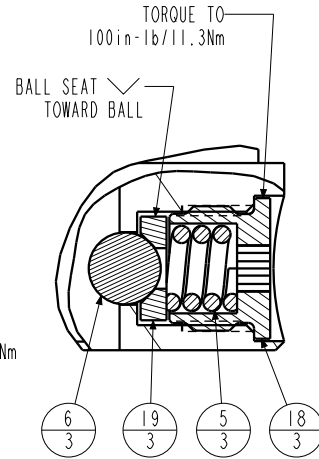

DETAIL A
SCALE 1.500

FOR REPLACEMENT
PLUNGER AND POSITION ROD ASSEMBLY
ORDER 62140127
KIT, SC, LP, TC, BF, PLUNGER & PR, 5000/22KN

No.	QTY	PART No.	DESCRIPTION	Std. Seal Kit	FKM Seal Kit
N/A	N/A	IS1505	INSTRUCTION SHEET, ARM INSTALLATION		
N/A	N/A	6V711048	SEAL KIT, FKM		
N/A	N/A	60711048	SEAL KIT, STANDARD		
22	1	39V10029	WIPER, PRESS-IN, (1-1/4)	X	X
21	1	81591834	CAM, SC, LP, 5000/22KN, STR, TC, PR		
20	1	81541817	BASE, SC, BF, LP, 22KN, PR		
19	3	81532108	SEAT, BALL, SC, LP, TC		
18	3	81532107	RETAINER, SC, LP, TC		
17	1	81500040	RING, LOCATOR, SC, LP, PR		
16	2	43068006	PLUG, 1/4 BSPP MALE		
15	1	39054008	BU RING, (-218)	X	X
14	1	39054007	BU RING, (-030)	X	39054021
13	1	39053005	WIPER, SNAP-IN, (1-1/4)	X	X
12	1	39052043	SEAL, LL, (1/4 X 1/8 X 1/8 X 1/2)	X	39V52043
11	1	39051042	O-RING, (-030)	X	39V01021
10	2	39051041	O-RING, (-006)	X	39V51041
9	2	39050042	O-RING, (-011)	X	39051025
8	1	39011060	SEAL, BEVEL W/HHEEL INSERT, 1-1/4 x 1/8 x 1-1/2	X	39052015
7	1	39011056	SEAL, CROWN, 1-9/16 x 1-3/4 x 5/32	X	39V11056
6	3	23650004	BALL, TUNGSTEN-CARBIDE. 250		
5	3	23350066	SPRING, COMPRESSION		
4	2	21500200	WASHER		
3	3	21500031	SHCS, M5 x 0.8 x 14, ALY		
2	10	21500023	SHCS, M5 X .8-66 X 30MM		
1	2	21500019	SCREW, CAP, BTNH, M3 X 6, ALY		

PARTS LIST



VEKTEK, INC.
1334 E. SIXTH AVE. P.O. BOX 625
EMPORIA, KS. 66801 U.S.A.

ASSEMBLIES AFFECTED

41422225PR

41422225PRF

PARTS LIST, ASSY, SC, LP, TC, BF, 22KN, DA, STR, PR

SIZE
A

MPL7213

REV
C

SHEET 1 OF 1

C	5770	RELEASE	JDW	08/02/25
REV	IN ACCORDANCE WITH ECN	EFFECTIVE DATE	REVISED BY	DATE
DRW BY:	JDW	DRAWING STATUS: Released		
DATE:	10/16/13	PRODUCTION APPROVED FOR RELEASED STATUS ONLY		

