

APPLY LUBRICANT TO ALL SEALS PRIOR TO INSTALLATION. DO NOT USE SILICONE TYPE LUBRICANTS. FOR PROPER ARM MOUNTING SEE IS1505.

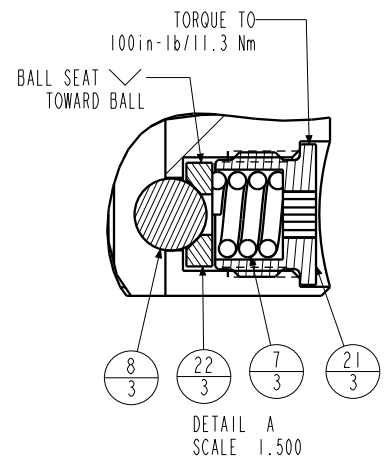

9 1 FOR REPLACEMENT PLUNGER AND POSITION ROD ASSEMBLY ORDER 62140122 KIT, SC, LP, TC, TF, PLUNGER & PR, 5000/22KN, LS

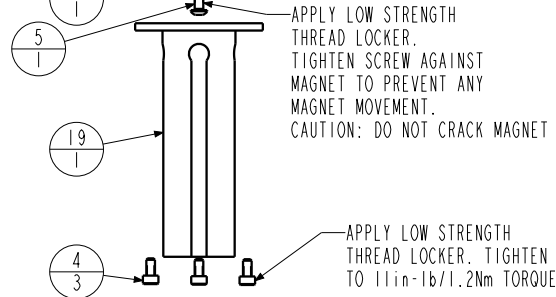
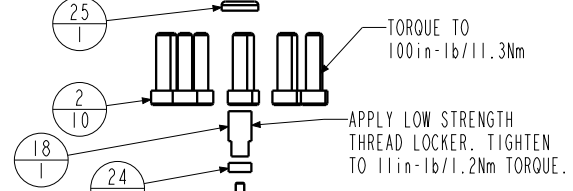
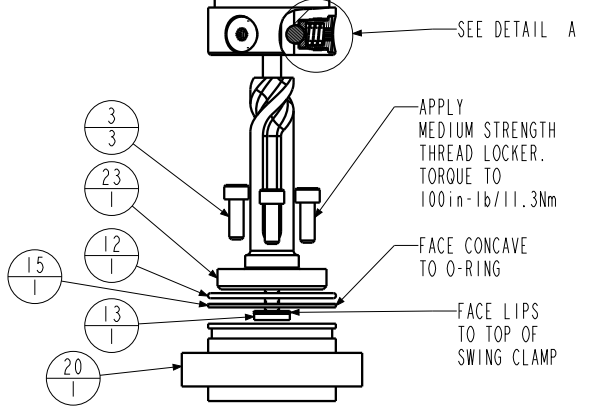

No.	QTY	PART No.	DESCRIPTION	Std. Seal Kit	FKM Seal Kit
N/A	N/A	IS1505	INSTRUCTION SHEET, ARM INSTALLATION		
N/A	N/A	6V711052	SEAL KIT, FKM		
N/A	N/A	60711052	SEAL KIT, STANDARD		
25	1	39V10029	WIPER, PRESS-IN, (1/4)	X	X
24	1	91100001	MAGNET, .130 x .312, PS		
23	1	81591837	CAM, SC, LP, 22KN, RH, LS, TC, PR		
22	3	81532108	SEAT, BALL, SC, LP, TC		
21	3	81532107	RETAINER, SC, LP, TC		
20	1	81531819	CAP, END, SC, LP, 22KN/5000, PR		
19	1	81500062	HOUSING, PS, MAG, SC, LP, LS		
18	1	81500060	ADAPTOR, PS, MAG, SC, LP		
17	2	43068006	PLUG, 1/4 BSPP MALE		
16	1	39054008	BU RING, (-218)	X	X
15	1	39054007	BU RING, (-030)	X	39054021
14	1	39053005	WIPER, SNAP-IN, (1-1/4)	X	X
13	1	39052043	SEAL, LL, (1/4 x 1/8 x 1/8 x 1/2)	X	39V52043
12	1	39051042	O-RING, (-030)	X	39V01021
11	2	39050042	O-RING, (-011)	X	39051025
10	1	39011060	SEAL, BEVEL WHEEL INSERT, 1-1/4 x 1/8 x 1-1/2	X	39052015
9	1	39011056	SEAL, CROWN, 1-9/16 x 1-3/4 x 5/32	X	39V11056
8	3	23650004	BALL, TUNGSTEN-CARBIDE .250		
7	3	23350066	SPRING, COMPRESSION		
6	2	21500200	WASHER		
5	1	21500044	SCREW, CAP, BTNH, M3-0.5 x 6, SSTL		
4	3	21500043	SHCS, M3-0.5 x 6 ALY		
3	3	21500031	SHCS, M5 x 0.8 x 14, ALY		
2	10	21500022	SHCS, M5 x .8-6G x 20, ALY		
1	2	21500019	SCREW, CAP, BTNH, M3 x 6, ALY		

## PARTS LIST

VEKTEK, INC.  
1334 E. SIXTH AVE. P.O. BOX 625  
EMPORIA, KS. 66801 U.S.A.

ASSEMBLIES AFFECTED	PARTS LIST, ASSY, SC, LP, TC, TF, 22KN, DA, RH, LS, PS
41462223PS	
41462223PSF	
SIZE A	MPL7220
	REV C

C	5770	RELEASE	JDW	08/02/25
REV	IN ACCORDANCE WITH ECN	EFFECTIVE DATE	REVISED BY	DATE
DRW BY:	JDW	DRAWING STATUS: <b>Released</b>		
DATE:	10/16/13	PRODUCTION APPROVED FOR RELEASED STATUS ONLY		

