

APPLY LUBRICANT TO ALL SEALS PRIOR TO INSTALLATION. DO NOT USE SILICONE TYPE LUBRICANTS. FOR PROPER ARM MOUNTING SEE 1S1505.

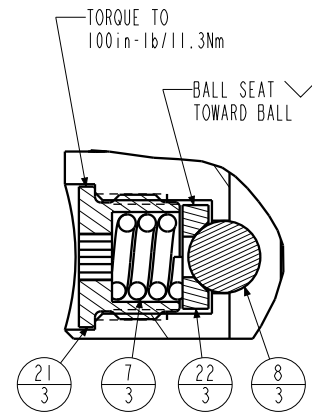

DETAIL A
SCALE 1.500

No.	QTY	PART No.	DESCRIPTION	Std Seal Kit	FKM Seal Kit
N/A	N/A	1S1505	INSTRUCTION SHEET, ARM INSTALLATION		
N/A	N/A	6V711048	SEAL KIT, FKM		
N/A	N/A	60711048	SEAL KIT, STANDARD		
26	1	39V10029	WIPER, PRESS-IN, (1/4)	X	X
25	1	91100001	MAGNET, .130 x .312, PS		
24	1	81591833	CAM, SC, LP, 5000/22KN, LH, TC, PR		
23	1	81541817	BASE, SC, BF, LP, 22KN, PR		
22	3	81532108	SEAT, BALL, SC, LP, TC		
21	3	81532107	RETAINER, SC, LP, TC		
20	1	81500061	HOUSING, PS, MAG, SC, LP		
19	1	81500060	ADAPTOR, PS, MAG, SC, LP		
18	2	43068006	PLUG, 1/4 BSPP MALE		
17	1	39054008	BU RING, (-218)	X	X
16	1	39054007	BU RING, (-030)	X	39054021
15	1	39053005	WIPER, SNAP-IN, (1-1/4)	X	X
14	1	39052043	SEAL, LL, (1/4 X 1/8 X 1/8 X 1/2)	X	39V52043
13	1	39051042	O-RING, (-030)	X	39V01021
12	2	39051041	O-RING, (-006)	X	39V51041
11	2	39050042	O-RING, (-011)	X	39051025
10	1	39011060	SEAL, BEVEL W/HEEL INSERT, 1-1/4 x 1/8 x 1-1/2	X	39052015
9	1	39011056	SEAL, CROWN, 1-9/16x1-3/4x5/32	X	39V11056
8	3	23650004	BALL, TUNGSTEN-CARBIDE .250		
7	3	23350066	SPRING, COMPRESSION		
6	2	21500200	WASHER		
5	1	21500044	SCREW, CAP, BTNH, M3-0.5 X 6, SSTL		
4	3	21500043	SHCS, M3-0.5 X 6 ALY		
3	3	21500031	SHCS, M5 X 0.8 X 14, ALY		
2	10	21500023	SHCS, M5 X .8-66 X 30MM		
1	2	21500019	SCREW, CAP, BTNH, M3 X 6, ALY		

PARTS LIST



VEKTEK, INC.
1334 E. SIXTH AVE. P.O. BOX 625
EMPORIA, KS. 66801 U.S.A.

ASSEMBLIES AFFECTED

4142222PS

4142222PSF

PARTS LIST, ASSY, SC, LP, TC, BF, 22KN, DA, LH, PS

SIZE
A

MPL7228

REV
C

SHEET 1 OF 1

C	5770	RELEASE	JDW	08/02/25
REV	IN ACCORDANCE WITH ECN	EFFECTIVE DATE	REVISED BY	DATE
DRW BY:	JDW	DRAWING STATUS: Released		
DATE:	10/16/13	PRODUCTION APPROVED FOR RELEASED STATUS ONLY		

READ ALL INSTRUCTIONS BEFORE INSTALLING ARMS FAILURE TO FOLLOW INSTALLATION INSTRUCTIONS WILL VOID PRODUCT WARRANTY !

–Installing or Positioning of Low Profile Swing Clamp Arms–

NOTE: If the arm is already installed on the plunger, loosen the cap screw.

CAUTION: Never attempt to rotate the arm before loosening the cap screw. This can damage the plunger rotating mechanism.

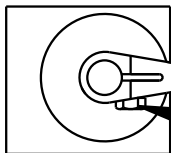

1. Rotate the arm to the desired radial position.
2. Tighten to the torque specification listed below.

MODEL	TORQUE ft-lb	TORQUE N-m
50001b & 22Kn	115 ft-lb	156 N-m
75001b & 33Kn	225 ft-lb	305 N-m

IT IS RECOMMEND THE CROSS BOLT
BE REPLACED IF THE ARM NEEDS
REMOVED AFTER IT HAS BEEN IN SERVICE.

CROSS BOLT	CROSS BOLT	CROSS BOLT	CROSS BOLT
5000 & 22KN	5000 & 22KN	7500 & 33KN	7500 & 33KN
SHORT LONG DOUBLE	UPREACH	SHORT LONG DOUBLE	UPREACH
21-5000-24	21-5000-25	21-5000-28	21-5000-25

Instruction Sheet



VEKTEK, INC.
1334 E. SIXTH AVE. P.O. BOX 625
EMPORIA, KS. 66801 U.S.A.

Arm Installation Instruction Sheet

Low Profile Swing Clamps

SIZE A 1S1505 REV C

FORM FEG041-1S.AS1Z, REV. B

C	2799	RELEASE	JDW	01/29/15
REV	IN ACCORDANCE WITH ECN	EFFECTIVE DATE	REVISED BY	DATE
DRW BY:	MES	DRAWING STATUS: Released		
DATE:	08/01/05	PRODUCTION APPROVED FOR RELEASED STATUS ONLY		

SHEET 1 OF 1