

APPLY LUBRICANT TO ALL SEALS PRIOR TO INSTALLATION. DO NOT USE SILICONE TYPE LUBRICANTS. FOR PROPER ARM MOUNTING SEE 1S1505.

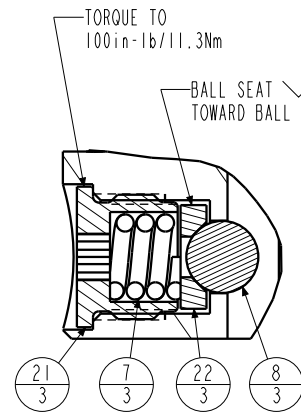

DETAIL A
SCALE 1.500

N/A	N/A	1S1505	INSTRUCTION SHEET, ARM INSTALLATION		
N/A	N/A	6V711048	SEAL KIT, FKM		
N/A	N/A	60711048	SEAL KIT, STANDARD		
26	1	39V10029	WIPER, PRESS-IN, (1/4)	X	X
25	1	91100001	MAGNET, -130 x .312, PS		
24	1	81591838	CAM, SC, LP, 22KN, LH, LS, TC, PR		
23	1	81541817	BASE, SC, BF, LP, 22KN, PR		
22	3	81532108	SEAT, BALL, SC, LP, TC		
21	3	81532107	RETAINER, SC, LP, TC		
20	1	81500062	HOUSING, PS, MAG, SC, LP, LS		
19	1	81500060	ADAPTOR, PS, MAG, SC, LP		
18	2	43068006	PLUG, 1/4 BSPP MALE		
17	1	39054008	BU RING, (-218)	X	X
16	1	39054007	BU RING, (-030)	X	39054021
15	1	39053005	WIPER, SNAP-IN, (1-1/4)	X	X
14	1	39052043	SEAL, LL, (1/4 X 1/8 X 1/8 X 1/2)	X	39V52043
13	1	39051042	O-RING, (-030)	X	39V01021
12	2	39051041	O-RING, (-006)	X	39V51041
11	2	39050042	O-RING, (-011)	X	39051025
10	1	39011060	SEAL, BEVEL W/HEEL INSERT, 1-1/4 x 1/8 x 1-1/2	X	39052015
9	1	39011056	SEAL, CROWN, 1-9/16 x 1-3/4 x 5/32	X	39V11056
8	3	23650004	BALL, TUNGSTEN-CARBIDE .250		
7	3	23350066	SPRING, COMPRESSION		
6	2	21500200	WASHER		
5	1	21500044	SCREW, CAP, BTNH, M3-0.5 X 6, SSTL		
4	3	21500043	SHCS, M3-0.5 X 6 ALY		
3	3	21500031	SHCS, M5 X 0.8 X 14, ALY		
2	10	21500023	SHCS, M5 X .8-66 X 30MM		
1	2	21500019	SCREW, CAP, BTNH, M3 X 6, ALY		
No.	QTY	PART No.	DESCRIPTION	Std. Seal Kit	FKM Seal Kit

PARTS LIST



VEKTEK, INC.
1334 E. SIXTH AVE. P.O. BOX 625
EMPORIA, KS. 66801 U.S.A.

ASSEMBLIES AFFECTED

41422227PS

41422227PSF

SIZE
A

MPLV7252

REV
C

SHEET 1 OF 1

FORM FEG035_PL_ASIZE, REV. B

C	5770	RELEASE	JDW	08/02/25
REV	IN ACCORDANCE WITH ECN	EFFECTIVE DATE	REVISED BY	DATE
DRW BY:	JDW	DRAWING STATUS: Released		
DATE:	03/04/19	PRODUCTION APPROVED FOR RELEASED STATUS ONLY		

