

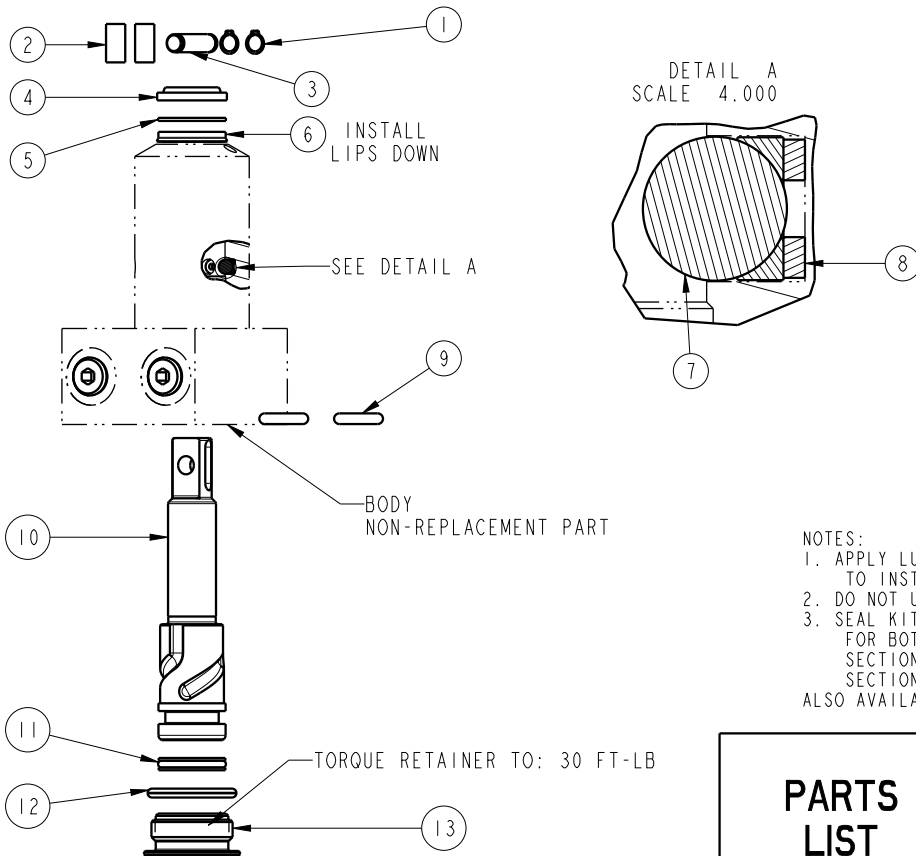

Prefix-000048-Suffix

NO.	QTY.	DESCRIPTION	MODEL NUMBER			STANDARD SEAL KIT	FLUOROCARBON SEAL KIT
			14-2209-2X-X	14-2213-2X-X	14-2218-20-X		
1	2	RING, RETAINING, EXT	23-0500-32	23-0500-36	23-0500-38	NO	NO
2	2	STOCK, CORD, NBR	23-3400-01	23-3400-03	23-3400-04	NO	NO
3	1	PIN, ROCKER, SC	81-4002-71	81-4002-73	81-4002-74	NO	NO
4	1	WIPER, ROD (FLUOROCARBON)	39-0530-01	39-0530-00	39-0530-05	YES	YES
5	1	BACK-UP RING, ROD (FLUOROCARBON)	39-F540-01	39-F540-02	39-0540-08	YES	YES
6	1	SEAL, ROD (STANDARD)	39-0100-20	39-0110-46	39-0110-60	YES	NO
		SEAL, ROD (FLUOROCARBON)	39-V100-20	39-V110-46	39-0520-15	NO	YES
7	3	BALL, STEEL ALLOY	23-6000-11	23-6000-02	23-6000-13	YES	YES
8	3	BALL SEAT ASSEMBLY	90-1999-57	90-1999-58	90-1999-59	YES	YES
9	2	O-RING, MANIFOLD (STANDARD)	39-0000-50	39-0000-50	39-0000-50	YES	NO
		O-RING, MANIFOLD (FLUOROCARBON)	39-0510-22	39-0510-22	39-0510-22	NO	YES
10	1	PLUNGER, RIGHT HAND (SHOWN)	81-4109-00	81-4113-00	81-4118-00	NO	NO
		PLUNGER, LEFT HAND	81-4109-01	81-4113-01	81-4118-01	NO	NO
		PLUNGER, RIGHT HAND, LS	81-4109-02	81-4113-02	N/A	NO	NO
		PLUNGER, LEFT HAND, LS	81-4109-03	81-4113-03	N/A	NO	NO
11	1	SEAL, PLUNGER (STANDARD)	39-H100-18	39-H110-30	39-H110-56	YES	NO
		SEAL, PLUNGER (FLUOROCARBON)	39-V100-18	39-V110-30	39-V110-56	NO	YES
12	1	O-RING, RETAINER (FLUOROCARBON)	39-0510-31	39-V510-43	N/A	YES	YES
		GASKET	N/A	N/A	39-T550-04	YES	YES
13	1	RETAINER	81-4000-29	81-4000-30	81-5318-00	NO	NO
N/A	N/A	SEAL KIT (STANDARD)	60-1400-26	60-1400-20	60-1400-36	INCLUDED IN KIT	
N/A	N/A	SEAL KIT (FLUOROCARBON)	6V-1400-26	6V-1400-20	6V-1400-36		



NOTES:
 1. APPLY LUBRICANT TO ALL SEALS PRIOR TO INSTALLATION.
 2. DO NOT USE SILICONE TYPE LUBRICANTS.
 3. SEAL KITS CONTAIN MANIFOLD MOUNT O-RINGS FOR BOTH BOTTOM FLANGE, (LARGE CROSS-SECTION), AND TOP FLANGE, (SMALL CROSS-SECTION), MODELS.
 ALSO AVAILABLE: IS-1500 INSTRUCTION SHEET

PARTS LIST	 VEKTEK, INC. 1334 E. SIXTH AVE. P.O. BOX 625 EMPORIA, KS. 66801 U.S.A.
ASSEMBLIES AFFECTED 14-2209-20-L, 14-2209-20-R 14-2209-21-L, 14-2209-21-R 14-2213-20-L, 14-2213-20-R 14-2213-21-L, 14-2213-21-R 14-2218-20-L, 14-2218-20-R	PARTS LIST, SC, BF, CLEVIS, DA
SIZE A	PL1461
REV A	SHEET 1 OF 1

A	5867	RELEASE	NPETERS	12/11/25
REV	IN ACCORDANCE WITH ECN	EFFECTIVE DATE	REVISED BY	DATE
DRW BY:	NPETERS	DRAWING STATUS: Released		
DATE:	12/3/25	PRODUCTION APPROVED FOR RELEASED STATUS ONLY		

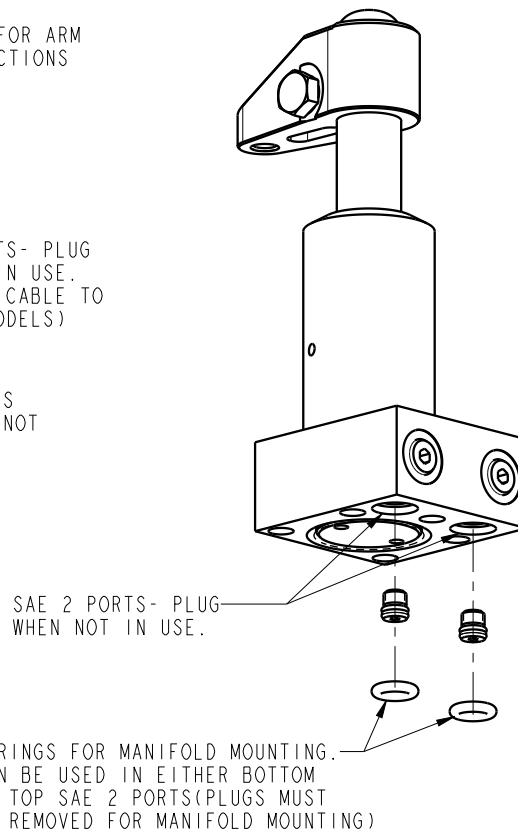
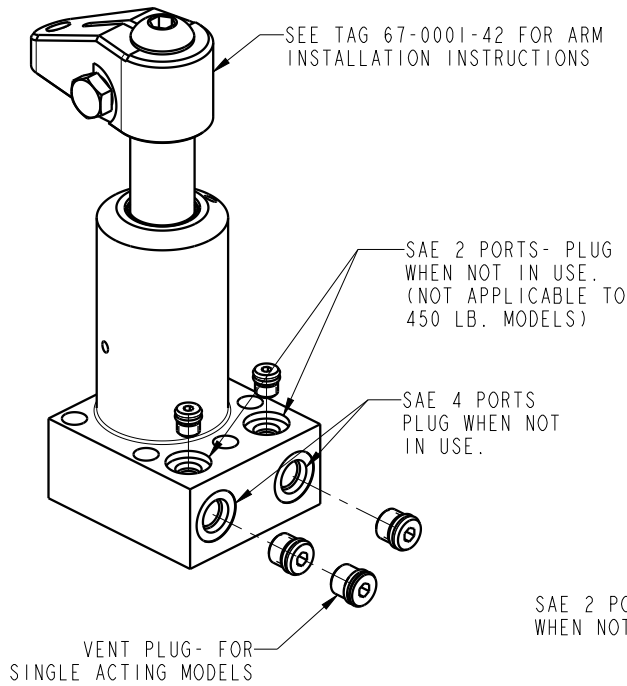

ALL SWING CLAMPS ARE SHIPPED WITH PLUGS OR VENTS INSTALLED IN EACH PORT.

REMOVE PLUGS AS NECESSARY TO CONNECT THE SWING CLAMP TO THE HYDRAULIC CIRCUIT. KEEP THESE PLUGS FOR POSSIBLE USE AT A LATER TIME.

ALL MATING SURFACES MUST BE FLAT WITHIN .003 INCHES WITH A SURFACE ROUGHNESS NOT EXCEED $63\mu\text{IN } R_A$

WHEN MANIFOLD MOUNTING, THE HYDRAULIC FLUID FEEDER HOLES SHOULD BE .09-.15 INCHES IN DIAMETER AND CONCENTRIC TO THE O-RING PORT WITHIN .030 INCHES.

INSTALLATION INSTRUCTIONS



VEKTEK, INC.
1334 E. SIXTH AVE. P.O. BOX 625
EMPORIA, KS. 66801 U.S.A.

ASSEMBLIES AFFECTED
Bottom Flange
Swing Clamps

SIZE
A

IS-1500

REV
F

F	4258	RELEASE	JDW	08/18/20
REV	IN ACCORDANCE WITH ECN	EFFECTIVE DATE	REVISED BY	DATE
DRW BY:	DRAWING STATUS: Released			
DATE:	PRODUCTION APPROVED FOR RELEASED STATUS ONLY			

FORM FEG041-IS-ASIZE, REV. B

SHEET 1 OF 1