

Prefix-000043-Suffix

APPLY LUBRICANT TO ALL SEALS
PRIOR TO INSTALLATION. DO NOT
USE SILICONE TYPE LUBRICANTS.

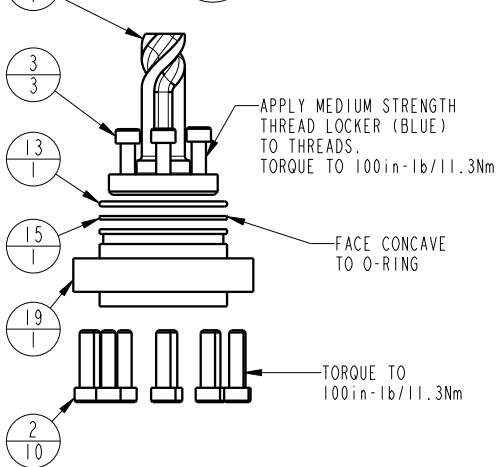
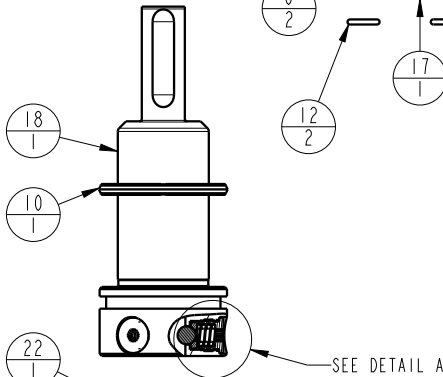
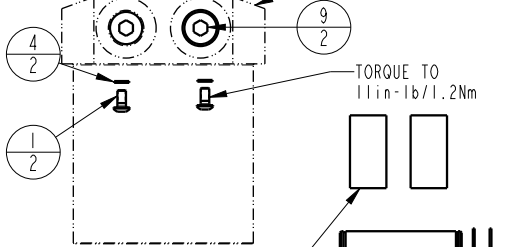
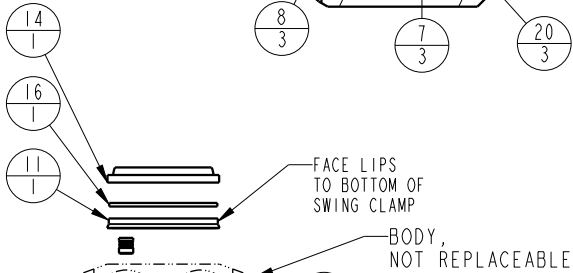
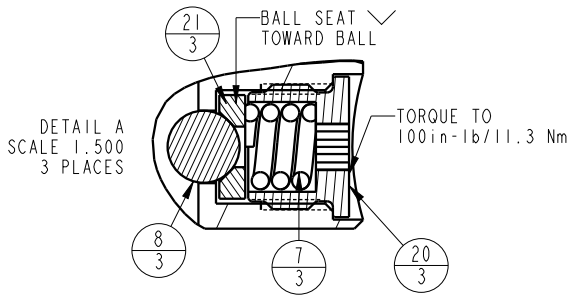

No.	QTY	PART No.	DESCRIPTION	STANDARD SEAL KIT	FKM SEAL KIT
N/A	N/A	6V711032	SEAL KIT (FKM)	INCLUDED IN KIT	
N/A	N/A	60711032	SEAL KIT (STANDARD)		
22	1	81591822	CAM, RIGHT HAND		
		81591823	CAM, LEFT HAND		
		81591824	CAM, STRAIGHT		
		81591827	CAM, RIGHT HAND, LONG STROKE		
		81591828	CAM, LEFT HAND, LONG STROKE		
		81591829	CAM, STRAIGHT, LONG STROKE		
21	3	81532108	SEAT, BALL, SC, LP, TC		
20	3	81532107	RETAINER, SC, LP, TC		
19	1	81531809	CAP, END, SC, LP, 22kN/5000		
18	1	81511813	PLUNGER, SC, LP, 5000&22KN, DA, CLEVIS		
		81511814	PLUNGER, SC, LP, 5000&22KN, DA, CLEVIS, LS		
17	1	81400274	PIN, ROCKER, SC, 7MPa, 50B		
16	1	39054008	BU RING, (-218)	X	X
15	1	39054007	BU RING, (-030)	X	39054021
14	1	39053005	WIPER, SNAP-IN, (1-1/4)	X	X
13	1	39051042	O-RING, (-030)	X	39V11056
12	2	39050042	O-RING, (-011)	X	39051025
11	1	39011060	SEAL, BEVEL W/HEEL INSERT	X	39052015
10	1	39011056	SEAL, CROWN, 1-9/16x1-3/4x5/32	X	39V11056
9	2	30601144	PLUG, SOCH, SAE 4		
8	3	23650004	BALL, TUNGSTEN-CARBIDE .250		
7	3	23350066	SPRING, COMPRESSION		
6	2	23340004	STOCK, CORD, .50 X 1.00, 50, NBR		
5	2	23050038	RING, RTNG, EXT, 0.469		
4	2	21500200	WASHER		
3	3	21500031	SHCS, M5 x 0.8 x 14, ALY		
2	10	21500022	SHCS, M5 x .8-6G x 20, ALY		
1	2	21500019	SCREW, CAP, BTNH, M3 X 6, ALY		

PARTS LIST



VEKTEK, INC.
1334 E. SIXTH AVE. P.O. BOX 625
EMPORIA, KS. 66801 U.S.A.

PARTS LIST, SC, LP, TC, TF, 5600, DA, CLEVIS

SIZE
A **PL1464**

REV
A

FORM FEG035_PL_ASIZE, REV. B

A	5867	RELEASE	NPETERS	12/11/25
REV	IN ACCORDANCE WITH ECN	EFFECTIVE DATE	REVISED BY	DATE
DRW BY:	NPETERS	DRAWING STATUS: Released		
DATE:	12/3/25	PRODUCTION APPROVED FOR RELEASED STATUS ONLY		

ASSEMBLIES AFFECTED
14061820, 14061821
14061822, 14061823
14061824, 14061825

SHEET 1 OF 1