

Lubricate all seals with clean hydraulic fluid prior to assembly.  
Do Not Use Silicone Based Lubricants.

ALSO AVAILABLE: ISI503, INSTALLATION SHEET

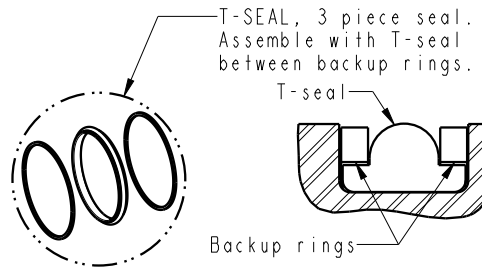
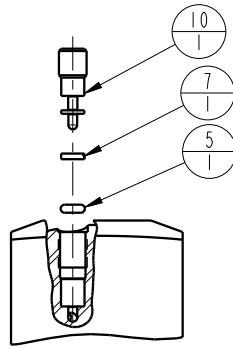
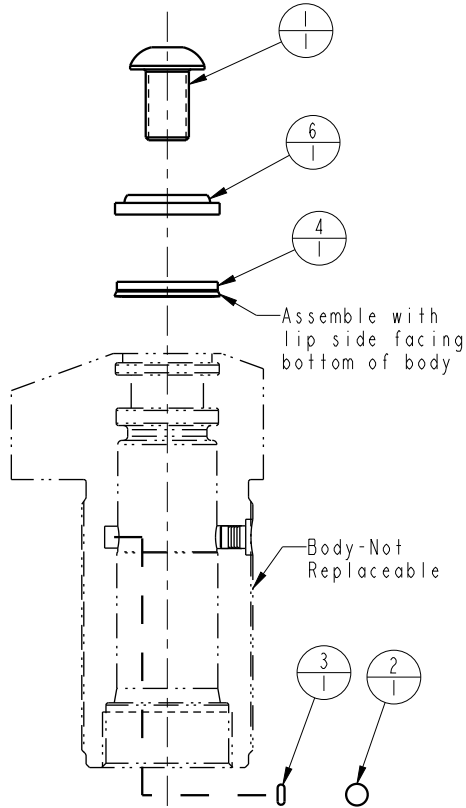

60-1502-08 Standard Seal Kit	6V-1502-08 Fluorocarbon Seal Kit
39-T550-02	39-T550-02
39-H100-18	39-V100-18
39-0100-20	39-V100-20
39-0530-01	39-0530-01
39-0540-29	39-0540-29
39-0500-00	39-V500-00
23-6000-11	23-6000-11
39-0000-19	39-0510-06

No.	QTY	PART No.	DESCRIPTION
12	1	39T55002	GASKET, (-021)
11	1	39H10018	SEAL, T, (11/16 X 5/32 X 7/8)
10	1	91500900	ASSY, STEM, SC, FC, 1100
9	1	81530901	RETAINER, SC, 1100
8	1	81510901	PLUNGER, SC, 1100#
7	1	39054029	BU RING, (-004)
6	1	39053001	WIPER, SNAP-IN, (5/8)
5	1	39050000	O-RING, (-004)
4	1	39010020	SEAL, BEVEL W/HEEL INSERT, 5/8 x 1/8 x 7/8
3	1	39000019	O-RING, (-003)
2	1	23600011	BALL, STEEL, ALLOY, .187
1	1	21410009	BHCS, 3/8-24 x 5/8, ALY

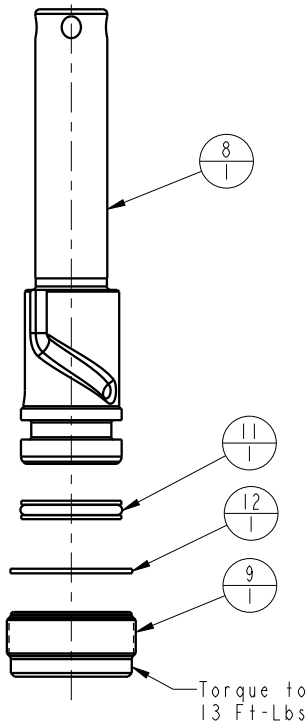

WEIGHT 1.87 LBS

### PARTS LIST



VEKTEK, INC.  
1334 E. SIXTH AVE. P.O. BOX 625  
EMPORIA, KS. 66801 U.S.A.

PARTS LIST, ASSY, SC TB, 1100, FC, DA

P	5756	RELEASE	JDW	07/10/25
REV	IN ACCORDANCE WITH ECN	EFFECTIVE DATE	REVISED BY	DATE
DRW BY:	JACOB	DRAWING STATUS: <b>Released</b>		
DATE:	4-24-96	PRODUCTION APPROVED FOR RELEASED STATUS ONLY		

ASSEMBLIES AFFECTED  
15020909L, 15020909R, 15020909S  
15020909LF, 15020909RF, 15020909SF

SIZE  
A PL-1500

REV  
P

FORM FEG035\_PL\_ASIZE, REV. B

SHEET 1 OF 1