

Prefix-000038-Suffix

Lubricate all seals with clean hydraulic fluid prior to assembly.
Do Not Use Silicone Based Lubricants.

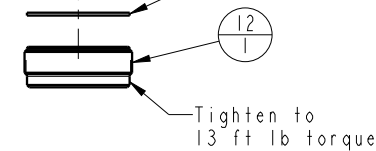
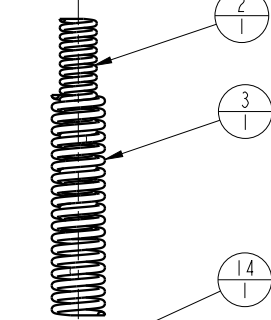
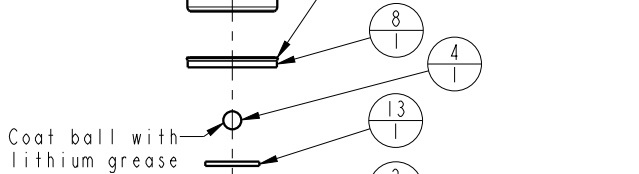
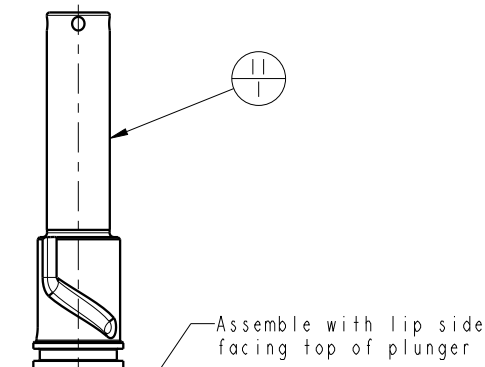
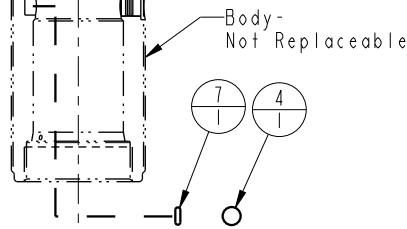
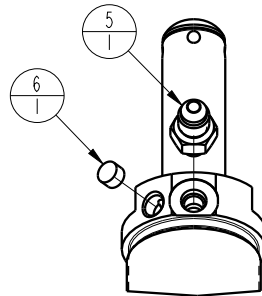
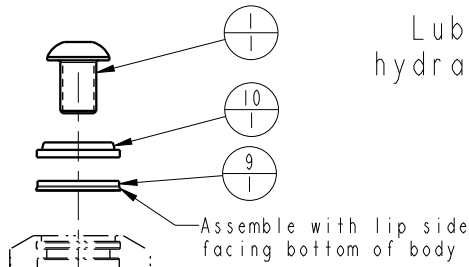

60-1501-13 Standard Seal Kit	6V-1501-13 Fluorocarbon Seal Kit	6I-1501-13 Spring Kit
39-T550-03	39-T550-03	39-T550-03
39-0110-27	39-0520-12	23-3130-09
39-0110-46	39-V110-46	23-3130-10
39-0530-00	39-0530-00	81-5913-01
23-6000-02(2 EA)	23-6000-02(2 EA)	23-6000-02(2 EA)
39-0000-20	39-0510-07	39-0000-20

No.	QTY	PART No.	DESCRIPTION
14	1	39T55003	GASKET, (-124)
13	1	81591301	DISK, PIVOT, BALL, SC, 2600, SA
12	1	81531301	RETAINER, SC, 2600
11	1	81511301	PLUNGER, SC, 2600#
10	1	39053000	WIPER, SNAP-IN, (7/8)
9	1	39011046	SEAL, BEVEL W/HEEL INSERT, 7/8 x 1/8 x 1 1/8
8	1	39011027	SEAL, BEVEL, 1-1/16 x 3/32 x 1-1/4
7	1	39000020	O-RING, (-005)
6	1	31091004	FILTER, BRONZE, SINTERED, .313, GR 46
5	1	30001542	CONNECTOR, 1/4 FLRD TBG - SAE 2
4	2	23600002	BALL, STEEL, ALLOY, .250
3	1	23313010	SPRING, COMPRESSION
2	1	23313009	SPRING, COMPRESSION
1	1	21410039	BHCS, 1/2-20 x 3/4, ALY

PARTS LIST



VEKTEK, INC.
1334 E. SIXTH AVE. P.O. BOX 625
EMPORIA, KS. 66801 U.S.A.

WEIGHT 3.26 LBS

Q	5877	RELEASE	JDW	01/20/26
REV	IN ACCORDANCE WITH ECN	EFFECTIVE DATE	REVISED BY	DATE
DRW BY:	VANDALSEM	DRAWING STATUS: Released		
DATE:	03/21/88	PRODUCTION APPROVED FOR RELEASED STATUS ONLY		

ASSEMBLIES AFFECTED
15011312L, 15011312LF
15011312R, 15011312RF
15011312S, 15011312SF

PARTS LIST, ASSY, SC, TB, 2600, SA, ADAPTER	
SIZE A	PL-1512
REV 0	

FORM FEG035_PL_ASIZE, REV. B

SHEET 1 OF 1