

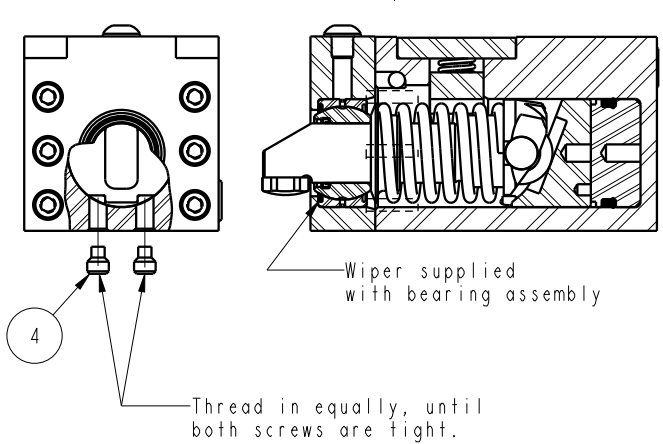

NO	QTY	PART NO	DESCRIPTION	STD SEAL KIT	FKM SEAL KIT	SPRING KIT
1	1	21410045	BHCS, 1/4-28 x 1/4, ALY			
2	4	21410049	SCREW, CAP, SOCH, 8-32 X 3/8, ALY			
3	6	21411035	SCREW, CAP, SOCH, 10-32 X 5/8, ALY			
4	2	21440018	SHSS, DOG POINT, 1/4-20x.31			
5	4	23350018	SPRING, COMPRESSION			X
6	1	23350023	SPRING, COMPRESSION			X
7	4	23350026	SPRING, COMPRESSION			X
8	1	30601122	PLUG, SOCH, SAE 2			
9	2	30601144	PLUG, SOCH, SAE 4			
10	2	31091006	FILTER, BRONZE, SINTERED, .250, 150µ			
11	1	39000050	O-RING, (-204)	X	39051022	
12	1	39011027	SEAL, BEVEL, 1-1/16 x 3/32 x 1-1/4	X	39051012	
13	1	39050061	SEAL, ROD	X	X	
14	1	64211001	END EFFECTOR, RETR CLAMP, 1700			
15	1	81511703	PISTON, FRONT, RETR CLAMP, 1700			
16	1	81511704	PISTON, REAR, RETR CLAMP, 1700			
17	1	81581301	MOUNT, CLAMP, RETRACT, 1700			
18	1	81592011	SPRING GUIDE			
19	1	81592012	SEAT, SPRING, CLAMP, RETRACT, 1700			
20	1	81592013	COVER, CLAMP, RETRACT, 1700			
21	2	90199924	PIN, DOWEL, 1/8 X 3/8, STD, STL, HDN			
22	1	91511301	ASSY, ARM, CLAMP, RETRACT, 1700			
23	1	91592009	ASSY, BEARING, RETR CLAMP, 1700			
N/A	N/A	60156100	KIT, SEAL	NOTED	N/A	N/A
N/A	N/A	6V156100	KIT, SEAL, FKM	N/A	NOTED	N/A
N/A	N/A	46100038	KIT, SPRING	N/A	N/A	NOTED



PARTS LIST	 VEKTEK VEKTEK, INC. 1334 E. SIXTH AVE. P.O. BOX 625 EMPORIA, KS. 66801 U.S.A.			
	ASSEMBLIES AFFECTED 15410801			
REV IN ACCORDANCE WITH ECN	RELEASE	JDW	11/01/18	PARTS LIST, ASSY, CLAMP, RETRACT, 1700
DATE: 6/28/99	EFFECTIVE DATE	REVISED BY	DATE	SIZE A
DRAWING STATUS: Released PRODUCTION APPROVED FOR RELEASED STATUS ONLY				REV G