

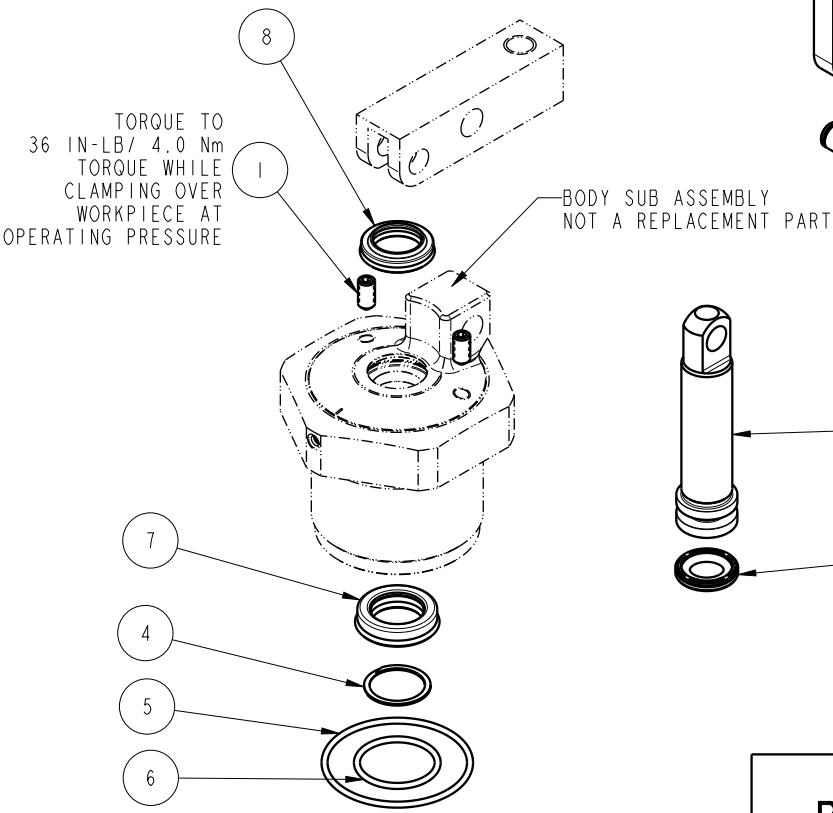

NO	QTY	PART NO	DESCRIPTION	STD SEAL KIT
1	2	21500318	SCREW, SET, CUP PT, M5 X .8 X 10	
2	2	23050034	RING, RTNG, EXT, 0.312	X
3	4	23050035	RING, RTNG, EXT, 0.354	X
4	1	23050051	RETAINING RING, SPIRAL, INTL	X
5	1	39001021	O-RING, (-030)	X
6	1	39050033	O-RING, (-020)	X
7	1	39052060	SEAL, ROD, RSD, 15, 85A, AU	X
8	1	39053041	SEAL, WIPER, SNAP IN, WED, 15, 94A, AU	X
9	1	39056032	SEAL, CAP, PISTON, 18, 94A, AU	X
10	2	81600147	LINK, LC, 7MPa, 40B	
11	2	81600152	PIN, LINK, LC, 7MPa, 40B	
12	1	81600157	PIN, PLUNGER, LC, 7MPa, 40B	
13	1	81600252	PLUNGER, LC, TL360, DA, 1400/6.22kN	
N/A	N/A	60160210	KIT, SEAL, ASSY, LC, CM, TL360, DA, 14001b	NOTED

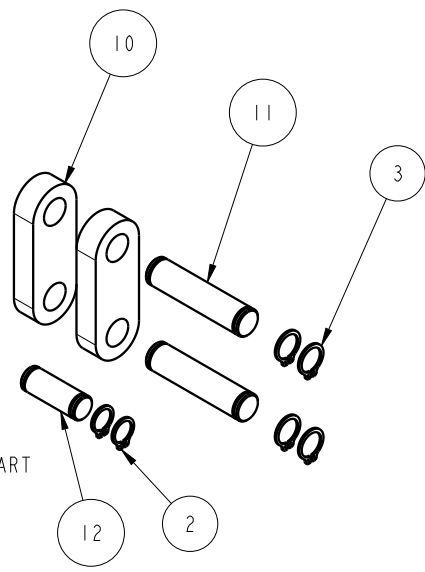

GREASE PACKET INCLUDED IN SEAL KIT

PARTS LIST	 VEKTEK VEKTEK, INC. 1334 E. SIXTH AVE. P.O. BOX 625 EMPORIA, KS. 66801 U.S.A.	
	PARTS LIST, ASSY, LC, CM, TL360, DA, 14001b ROTARY LUG	
ASSEMBLIES AFFECTED 16-4218-00	SIZE A	REV B

B	5217	RELEASE	ALS	12/11/23
REV	IN ACCORDANCE WITH ECN	EFFECTIVE DATE	REVISED BY	DATE
DRW BY:	A. THOMSEN	DRAWING STATUS: Released		
DATE:	05-MAY-2020	PRODUCTION APPROVED FOR RELEASED STATUS ONLY		

SHEET 1 OF 1