

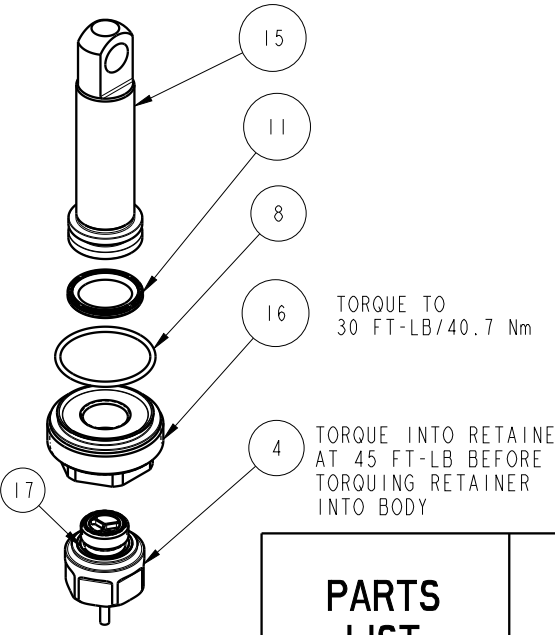

NO	QTY	PART NO	DESCRIPTION	STD SEAL KIT
1	2	21500320	SCREW, SET, CUP PT, M8 X 1.25 X 14	
2	4	23050023	RING, RTNG, EXT, 0.500	X
3	2	23050038	RING, RTNG, EXT, 0.469	X
4	1	29740200	SENSOR, ULTRASONIC, MI2, 1m	
5	2	30601122	PLUG, SOCH, SAE 2	
6	2	30601144	PLUG, SOCH, SAE 4	
7	2	39000050	O-RING, (-204)	X
8	1	39051152	O-RING, (34mm X 2)	X
9	1	39052062	SEAL, ROD, RSD, 22, 85A, AU	X
10	1	39053043	SEAL, WIPER, SNAP IN, WED, 22, 94A, AU	X
11	1	39056034	SEAL, CAP, PISTON, 28, 94A, AU	X
12	2	81600149	LINK, LC, 7MPa, 63B	
13	2	81600154	PIN, LINK, LC, 7MPa, 63B	
14	1	81600159	PIN, PLUNGER, LC, 7MPa, 63B	
15	1	81600254	PLUNGER, LC, TL360, DA, 3600/15.9kN	
16	1	81600332	CAP, LC, TL360, 3600/15.9kN, US	
17	1	43000040	SENSOR, FACE SEAL	
N/A	N/A	60160204	KIT, SEAL, ASSY, LC, TL360, DA, 3600 LB	NOTED

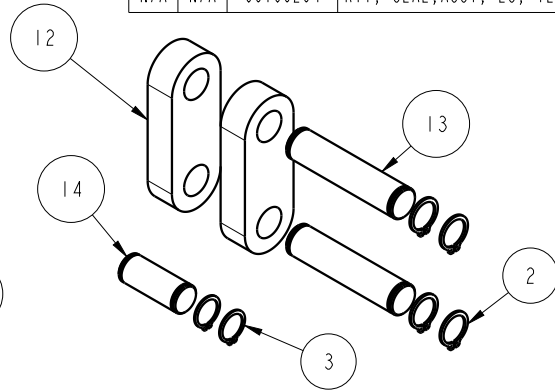
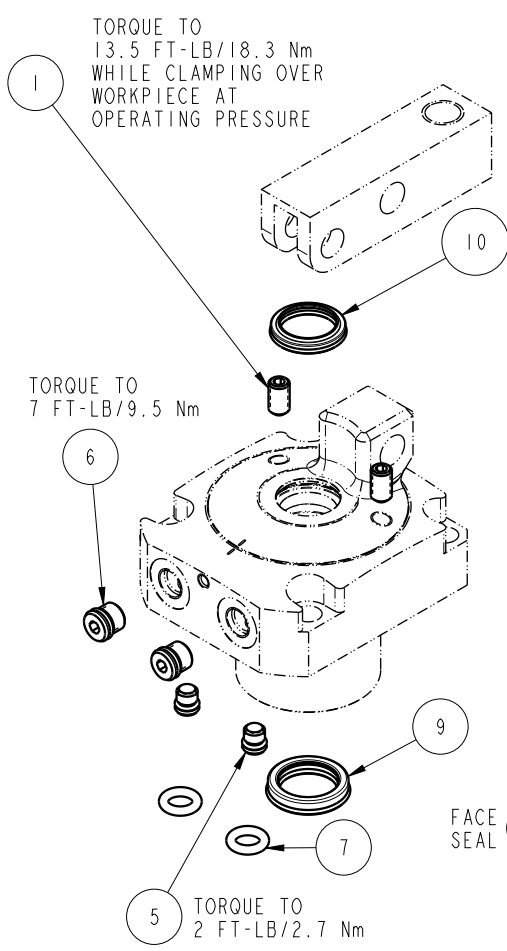

<b>PARTS LIST</b>	 <b>VEKTEK</b> VEKTEK, INC. 1334 E. SIXTH AVE. P.O. BOX 625 EMPORIA, KS. 66801 U.S.A.	
	<b>PARTS LIST, ASSY, LC, TL360, DA, 3600lb, US</b>	
ASSEMBLIES AFFECTED 16-3228-00-US	SIZE A	REV A

A	5531	RELEASE	ALS	11/5/24
REV	IN ACCORDANCE WITH ECN	EFFECTIVE DATE	REVISED BY	DATE
DRW BY: ALS	<b>DRAWING STATUS: Released</b> PRODUCTION APPROVED FOR RELEASED STATUS ONLY			
DATE: 10/4/24				