

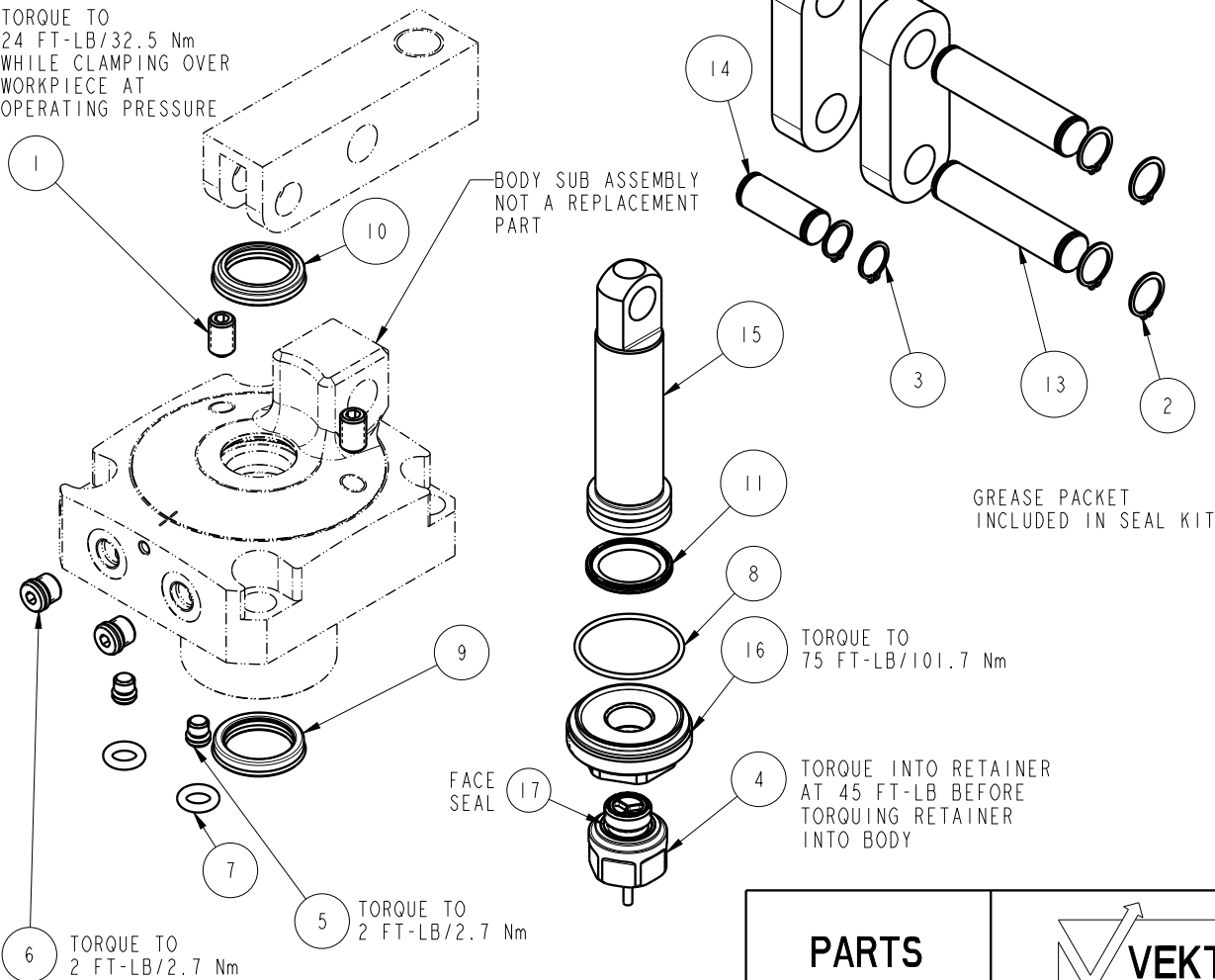

NO	QTY	PART NO	DESCRIPTION	STD SEAL KIT
1	2	21500331	SCREW, SET, CUP PT, M10 X 1.5 X 16	
2	4	23050024	RING, RTNG, EXT, 0.625	X
3	2	23050048	RING, RTNG, EXT, 0.551	X
4	1	29740200	SENSOR, ULTRASONIC, M12, 1m	
5	2	30601122	PLUG, SOCH, SAE 2	
6	2	30601144	PLUG, SOCH, SAE 4	
7	2	39000050	O-RING, (-204)	X
8	1	39051153	O-RING, (38mm X 2)	X
9	1	39052063	SEAL, ROD, RSD, 26, 85A, AU	X
10	1	39053044	SEAL, WIPER, SNAP IN, WED, 26, 94A, AU	X
11	1	39056012	SEAL, CAP, PISTON, 32, 94A, AU	X
12	2	81600171	LINK, LC, TL360, 5000/22.3kN	
13	2	81600172	PIN, LINK, LC, TL360, 5000/22.3kN	
14	1	81600173	PIN, PLUNGER, LC, TL360, 5000/22.3kN	
15	1	81600255	PLUNGER, LC, TL360, DA, 5000/22.3kN	
16	1	81600333	CAP, LC, TL360, 5000/22.3kN, US	
17	1	43000040	SENSOR, FACE SEAL	NOTED
N/A	N/A	60160205	KIT, SEAL, ASSY, LC, TL360, DA, 5000 1b	N/A

TORQUE TO
24 FT-LB/32.5 Nm
WHILE CLAMPING OVER
WORKPIECE AT
OPERATING PRESSURE



PARTS LIST	 VEKTEK VEKTEK, INC. 1334 E. SIXTH AVE. P.O. BOX 625 EMPORIA, KS. 66801 U.S.A.	
	ASSEMBLIES AFFECTED 16-3232-00-US	PARTS LIST, ASSY, LC, TL360, DA, 50001b, US
SIZE A	PL1640	REV A

A	5531	RELEASE	ALS	11/5/24
REV	IN ACCORDANCE WITH ECN	EFFECTIVE DATE	REVISED BY	DATE
DRW BY: ALS	DRAWING STATUS: Released			
DATE: 10/4/24	PRODUCTION APPROVED FOR RELEASED STATUS ONLY			

FORM FEG035_PL_AS1ZE, REV. B