

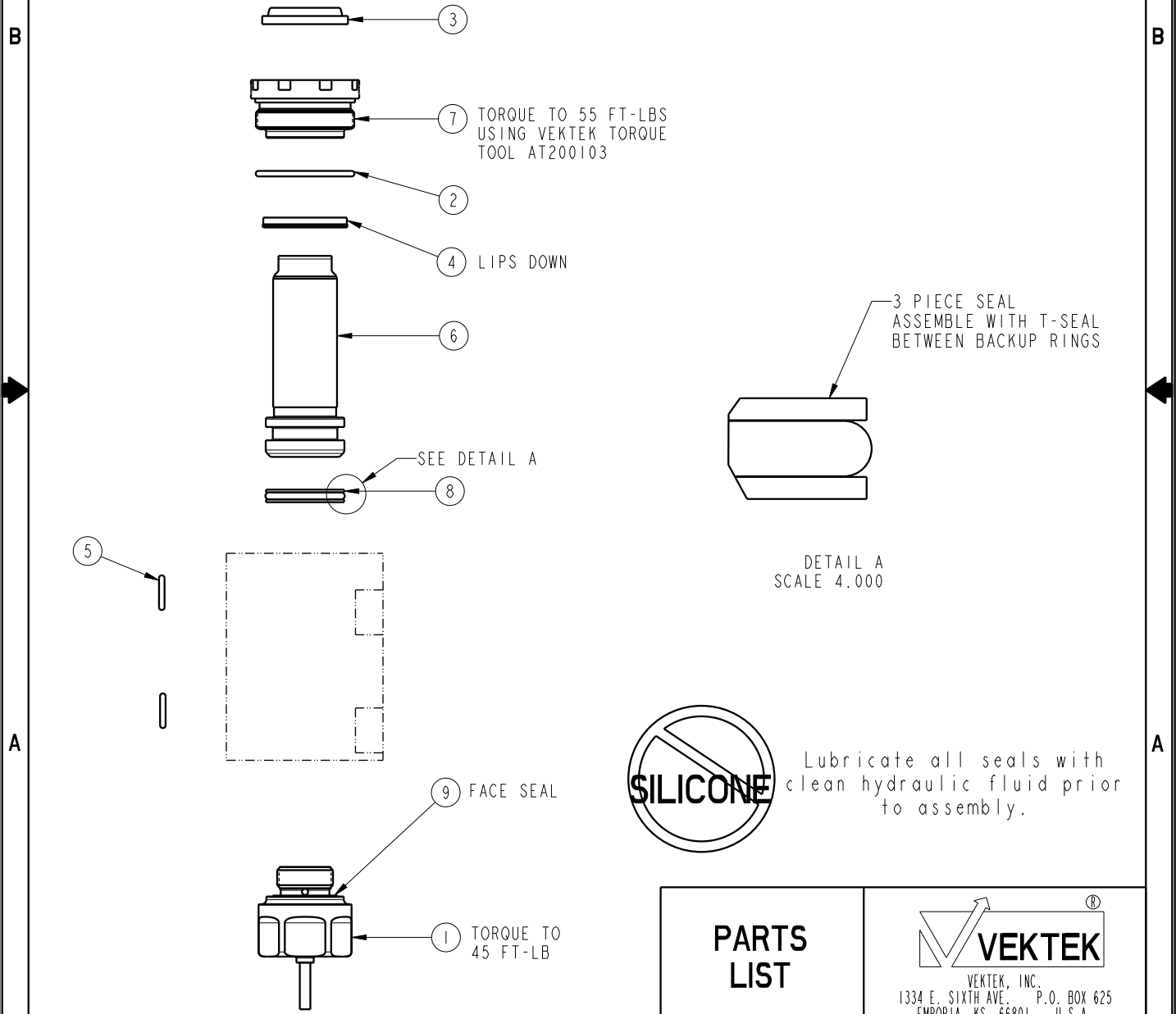

NO.	QTY	DESCRIPTION	MODEL NUMBER				STANDARD SEAL KIT	FKM SEAL KIT
			21-1210-00-US	21-1210-01-US	21-1210-04-US	21-1210-02-US		
1	1	SENSOR, ULTRASONIC, M12, 1m	29740200	29740200	29740200	29740200		
2	1	O-RING, (-024)	39001011	39001011	39001011	39001011	X	39012013
3	1	WIPER, SNAP-IN, (13/16)	39012008	39012008	39012008	39012008	X	X
4	1	SEAL, LL, (13/16X1/8X1/8X1-1/16)	39011045	39011045	39011045	39011045	X	39012005
5	1	O-RING, (-011)	39050042	39050042	39050042	39050042	X	39051025
6	1	PISTON, CYL, 3900, US	82011010	82011011	82011018	82011019		
7	1	GLAND, CYL, 3900 & 17.8 kN	82031002	82031002	82031002	82031002		
8	1	SEAL, T, (13/16 X 5/32 X 1)	39H10017	39H10017	39H10017	39H10017	X	39V10017
9	1	SENSOR, FACE SEAL	43000040	43000040	43000040	43000040		
	1	SENSOR, FACE SEAL, FKM	43000041	43000041	43000041	43000041		
N/A	N/A	SEAL KIT, STANDARD	60210200	60210000	60210200	60210200	NOTED	
N/A	N/A	SEAL KIT, FKM	6V210210	6V210210	6V210210	6V210210		NOTED



PARTS LIST	 VEKTEK VEKTEK, INC. 1334 E. SIXTH AVE. P.O. BOX 625 EMPORIA, KS. 66801 U.S.A.
	ASSEMBLIES AFFECTED 21-1210-00-US, 21-1210-01-US 21-1210-04-US, 21-1210-02-US
PARTS LIST, ASSY, CYL, BB, MM, 3900, DA, US	SIZE A PL21010 REV B

B	5956	RELEASE	ALS	5/6/26
REV	IN ACCORDANCE WITH ECN	EFFECTIVE DATE	REVISED BY	DATE
DRW BY:	ALS	DRAWING STATUS: Released		
DATE:	10/8/24	PRODUCTION APPROVED FOR RELEASED STATUS ONLY		