

Lubricate all seals with clean hydraulic fluid prior to assembly.  
Do not use silicone based lubricants.

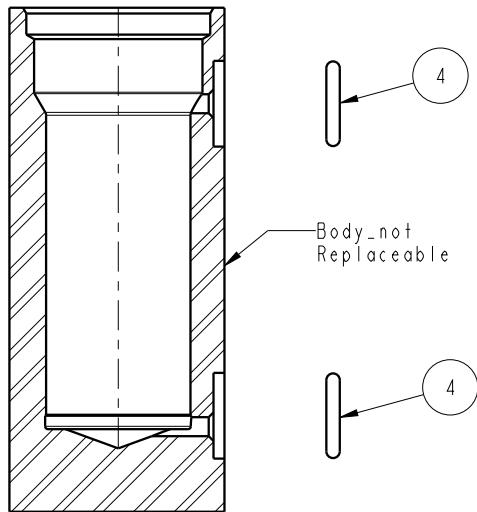
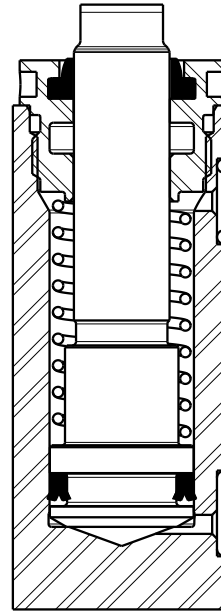
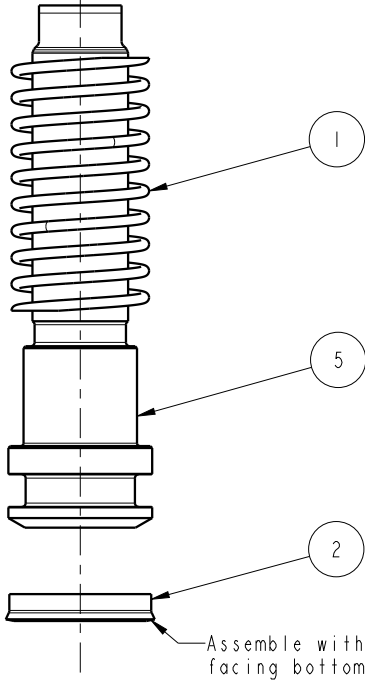
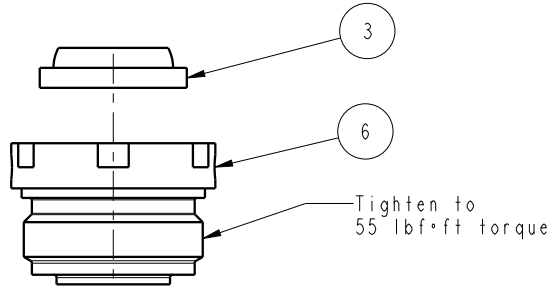

Standard Seal Kit 60-2101-00	Fluorocarbon Seal Kit 6V-2101-00	Spring Kit 61-2004-08
39-0100-13	39-0120-00	23-3130-06
39-0120-11	39-0120-11	
39-0500-42 (2)	39-0510-25 (2)	

No.	QTY	PART No.	DESCRIPTION
6	1	82030802	GLAND, CYL, BB, DA, 2200
5	1	82010804	PISTON, CYL, BB, 2200, .75 STRK
4	2	39050042	O-RING, (-011)
3	1	39012011	WIPER, SNAP-IN, (1/2)
2	1	39010013	SEAL, BEVEL, 9/16 X 3/32 X 3/4
1	1	23313006	SPRING, COMPRESSION

## PARTS LIST



VEKTEK, INC.  
1334 E. SIXTH AVE. P.O. BOX 625  
EMPORIA, KS. 66801 U.S.A.

Model Number  
21-1108-01  
21-1108-01F

ASSY, CYL, BB, MM, 2200, .75 STRK, SA

SIZE  
A

PL2170

REV  
E

E	5499	RELEASE	NPETERS	9/23/24
REV	IN ACCORDANCE WITH ECN	EFFECTIVE DATE	REVISED BY	DATE
DRW BY:	JACOB	<b>DRAWING STATUS: Released</b>		
DATE:	02-13-00	PRODUCTION APPROVED FOR RELEASED STATUS ONLY		

FORM FEG035\_PL\_ASIZE, REV. B

SHEET 1 OF 1