

LUBRICATE ALL SEALS WITH CLEAN HYDRAULIC OIL PRIOR TO ASSEMBLY.
DO NOT USE SILICONE BASED LUBRICANTS.

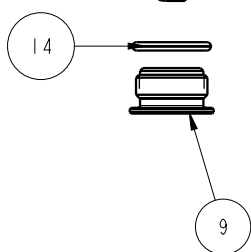

N/A	N/A	61250002	SPRING KIT	N/A	N/A	NOTED
N/A	N/A	6V254102	SEAL KIT, FKM	N/A	NOTED	
N/A	N/A	60254102	SEAL KIT, STANDARD	NOTED		
14	1	39V00036	O-RING, (-908)			
13	1	39F54000	BU RING, (-111)			
12	1	91590001	ASSY, BREATHER, SAE 2			
11	1	81590501	ROD, SUPPORT, SPRING, SC, 450			
10	1	81510500	PLUNGER, SC, 450			
9	1	81400028	RETAINER, SC, HS, 450			
8	1	39053004	WIPER, SNAP-IN, (7/16)			
7	1	39010038	SEAL, BEVEL, 7/16 x 3/32 x 5/8	X	39052014	
6	1	39010036	SEAL, BEVEL, 3/8 x 3/32 x 9/16	X	39052010	
5	2	30871120	ASSY, ADAPTER, SC, TF, MM	X	30871120F	
4	3	30601122	PLUG, SOCH, SAE 2			
3	1	23600014	BALL, STEEL, ALLOY, .156			
2	1	23311017	SPRING, COMPRESSION			X
1	1	23310008	SPRING, COMPRESSION			X
No.	QTY	PART No.	DESCRIPTION	Std. Seal kit	FKM Seal Kit	Spring Kit

PARTS LIST

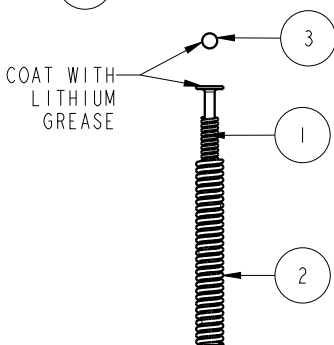
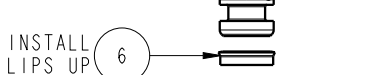
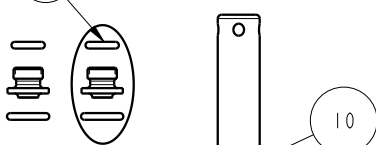
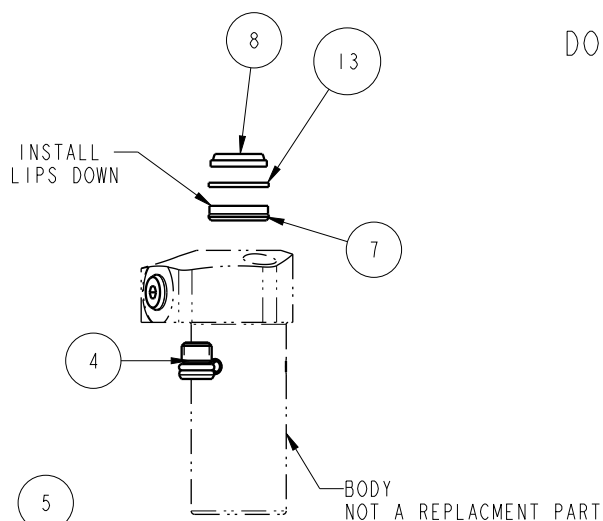

VEKTEK, INC.
1334 E. SIXTH AVE. P.O. BOX 625
EMPORIA, KS. 66801 U.S.A.

ASSEMBLIES AFFECTED
25610500
25610500F

PARTS LIST ASSY, CYL, PULL, TF, 470

SIZE
A PL2523

REV
A

SHEET 1 OF 1

FORM FEG035_PL_ASIZE, REV. B

A	4576	RELEASE	RLK	12/30/21
REV	IN ACCORDANCE WITH ECN	EFFECTIVE DATE	REVISED BY	DATE
DRW BY:	RLK	DRAWING STATUS: Released		
DATE:	12/30/21	PRODUCTION APPROVED FOR RELEASED STATUS ONLY		