

Air Hydraulic Boosters

Vekttek, Inc.
1334 East Sixth Avenue
Emporia, Ks. 66801
1-800-992-0236
www.vektek.com



Table of Contents

Section I Preliminary Information.....	3
Section II Description & Specifications.....	4
Section III Hydraulic Fluid.....	5
Section IV Installation.....	12
Section V Control Valves.....	13
Section VI Maintenance.....	15
Section VII Trouble Shooting.....	19
Section VIII Parts Lists.....	21
Section IX Warranty and Return Information.....	23

VektorFlo® is a registered trademark of Vektek, Inc.

Vektek, Inc. reserves the right to change specifications without notice in an ongoing product improvement process.

Vektek, Inc.
1334 East Sixth Avenue
Emporia, KS 66801
1-800-992-0236
sales@vektek.com
www.vektek.com

Preliminary Information

Please read and follow these instructions prior to booster set up and operation.

-Remove the booster from the shipping container. **Do not** remove any plugs or valves until the booster has been installed.

-Visually inspect all components for shipping damage. Report any damage to the carrier immediately. The carrier is responsible for all shipping damage.

-Install a filtered air supply to the booster. Pressure at the booster connection must not exceed the maximum allowable input pressure, listed in Section II.

-**DO NOT** use pipe joint compound, thread sealing tape, or other sealing materials with the SAE 4 O-ring port at the hydraulic output connection. These materials can contaminate the hydraulic system, and damage seals and sealing surfaces. The presence of such materials will void the booster warranty.

-Tighten threaded connections securely. Quick disconnect couplings must be securely fastened. **NEVER** disconnect or connect any hydraulic fittings while the system is pressurized.

WARNING

Loose or improperly assembled fittings can create safety hazards.
NEVER touch a leaking high-pressure hydraulic stream. Failure to comply with this warning may result in serious personal injury.

-Use only hydraulic equipment rated at 5,000 psig, working pressure. Caution must be used with 54:1 boosters. At an inlet pressure of 125-psig, the hydraulic outlet pressure will be approximately 6750 psi. Vekttek devices are rated for a maximum working pressure of 5000 psi. The input pressure for the 54:1 booster should not exceed 92 psi when using Vekttek devices. **Vekttek devices must never be used at pressures above 5000 psi.**

-**Do not** connect or disconnect the air supply to the booster while under pressure. First turn off the air supply and relieve the pressure on the booster.

-Train personnel with regard to safe operating procedures. Set and enforce work rules that help prevent property damage or personal injury.

Section II

Description and Specifications

- 1.0** Pneumatically actuated hydraulic boosters utilize low-pressure air to produce high-pressure oil. A larger air piston, acting on a smaller hydraulic piston, multiplies the output pressure by factors of 11, 22, 40 or 54. The forward motion of the hydraulic piston (plunger) displaces oil in the cylinder (barrel) and creates hydraulic pressure in the clamping circuit.
- 2.0** A manual, pilot, or electrical pneumatic five port, two-position valve must be used to provide double acting control of the air piston. As the air piston is returned to its starting position, hydraulic oil in the system is drawn back into the oil reservoir (aided by springs inside the single acting devices). The pilot pressure range is 20-150psi.
- 3.0** Vektek boosters are designed to operate one (1) clamping circuit composed of single acting devices, only. Boosters are not to be used on palletized systems, where the power source is disconnected from the pressurized clamping circuit.
- 4.0** Boosters may be mounted horizontally or vertically, by using the mounting kit (p/n 55-0390-06) or the tapped holes in the head and base plates. If the booster is to be mounted vertically, the oil reservoir end (high pressure outlet end) must be uppermost. Boosters are shipped with oil in the reservoir. Replenish oil as needed. See Section III for the correct oil.

Basic Booster Model	Booster with Manual Control	Booster with 115 VAC Control	Booster with 24 VDC Control	Booster with Pilot Control	Ratio	Useable Oil Volume	Maximum Air Input Pressure
55-0184-00	55-0284-16	55-0284-17	55-0284-18	55-0284-19	11:1	11.1 cu. in.	125 psi
55-0104-00	55-0204-16	550204-17	55-0204-18	55-0204-19	22:1	5.6 cu. in.	125 psi
55-0114-02	55-0214-16	55-0214-17	55-0214-18	55-0214-19	40:1	3.2 cu. in.	125 psi
55-0114-04	55-0224-16	55-0224-17	55-0224-18	55-0224-19	54:1	2.4 cu. in.	*

***At 125 psi, the 54:1 ratio booster will produce 6750 psi of hydraulic pressure. Vektek devices are rated at a maximum of 5000 psi. Do not use any Vektek device at pressures above 5000 psi. Do not exceed 92 psi. input pressure to use Vektek devices at 5000 psi hydraulic pressure,**

Section III

Hydraulic Oil

VektorFlo® hydraulic oil, p/n 65-0010-01, is recommended for all Vektek boosters.

VektorFlo® hydraulic oil is a premium grade of petroleum based oil with anti-wear additives. VektorFlo® hydraulic oil also includes additives that inhibit corrosion, rust, oxidation, and foaming. VektorFlo oil has an ISO viscosity grade of VG32. See the attached MSDS for additional information.

Other brand names of oil, that conform to ISO 11158, category HL/HM, grade VG 32 hydraulic oil may be used. Vektek recommends that any oil already in the hydraulic system be completely removed before replacement with another brand. The mixing of different brands of oils is not recommended.

The use of hydraulic oil with a viscosity higher than VG 32 will cause a slower return speed of single acting devices. ISO VG 46 oil is suitable for use in Vektek boosters and may be used if it is considered necessary.

Safety Data Sheet

According to OSHA HCS 2012 (29 CFR 1910.1200)



SECTION 1: Identification

Product Identifier **Megaflow® AW Hydraulic Oil**

Other means of identification Phillips 66 Megaflow® AW Hydraulic Oil 22
Phillips 66 Megaflow® AW Hydraulic Oil 32
Phillips 66 Megaflow® AW Hydraulic Oil 46
Phillips 66 Megaflow® AW Hydraulic Oil 68
Phillips 66 Megaflow® AW Hydraulic Oil 100
Phillips 66 Megaflow® AW Hydraulic Oil 150
Phillips 66 Megaflow® AW Hydraulic Oil 220
Phillips 66 Megaflow® AW Hydraulic Oil 320

SDS Number **LBPH814637**

Relevant identified uses Hydraulic Fluid

Uses advised against All others

24 Hour Emergency Phone Number CHEMTREC 1-800-424-9300
CHEMTREC Mexico 01-800-681-9531

Manufacturer/Supplier	SDS Information	Customer Service
Phillips 66 Lubricants P.O. Box 4428 Houston, TX 77210	Phone: 800-762-0942 Email: SDS@P66.com URL: www.Phillips66.com	U.S.: 800-368-7128 or International: 1-832-765-2500 Technical Information 1-877-445-9198

SECTION 2: Hazard identification

Classified Hazards **Hazards Not Otherwise Classified (HNOC)**

This material is not hazardous under the criteria of the Federal OSHA Hazard Communication Standard 29CFR 1910.1200. PHNOC: None known

HHNOC: None known

Label Elements
No classified hazards

SECTION 3: Composition/information on ingredients

Chemical Name	CASRN	Concentration ¹
Distillates, petroleum, hydrotreated heavy paraffinic	64742-54-7	>99

¹ All concentrations are percent by weight unless ingredient is a gas. Gas concentrations are in percent by volume.

SECTION 4: First aid measures

Eye Contact: If irritation or redness develops from exposure, flush eyes with clean water. If symptoms persist, seek medical attention.

Skin Contact: First aid is not normally required. However, it is good practice to wash any chemical from the skin. If product is injected into or under the skin, or into any part of the body, regardless of the appearance of the wound or its size, the individual should be evaluated immediately by a physician. (see Note to Physician)

Inhalation: First aid is not normally required. If breathing difficulties develop, move victim away from source of exposure and into fresh air in a position comfortable for breathing. Seek immediate medical attention.

Ingestion: First aid is not normally required; however, if swallowed and symptoms develop, seek medical attention.

Most important symptoms and effects, both acute and delayed: Inhalation of oil mists or vapors generated at elevated temperatures may cause respiratory irritation. Accidental ingestion can result in minor irritation of the digestive tract, nausea and diarrhea.

Notes to Physician: Acute aspirations of large amounts of oil-laden material may produce a serious aspiration pneumonia. Patients who aspirate these oils should be followed for the development of long-term sequelae. Inhalation exposure to oil mists below current workplace exposure limits is unlikely to cause pulmonary abnormalities. When using high-pressure equipment, injection of product under the skin can occur. In this case, the casualty should be sent immediately to the hospital. Do not wait for symptoms to develop. High-pressure hydrocarbon injection injuries may produce substantial necrosis of underlying tissue despite an innocuous appearing external wound. These injuries often require extensive emergency surgical debridement and all injuries should be evaluated by a specialist in order to assess the extent of injury. Early surgical treatment within the first few hours may significantly reduce the ultimate extent of injury.

SECTION 5: Firefighting measures

NFPA 704 Hazard Class

Health: 0 Flammability: 1 Instability: 0



0 (Minimal)
1 (Slight)
2 (Moderate)
3 (Serious)
4 (Severe)

Extinguishing Media: Dry chemical, carbon dioxide, foam, or water spray is recommended. Water or foam may cause frothing of materials heated above 212°F / 100°C. Carbon dioxide can displace oxygen. Use caution when applying carbon dioxide in confined spaces. Simultaneous use of foam and water on the same surface is to be avoided as water destroys the foam.

Specific hazards arising from the chemical

Unusual Fire & Explosion Hazards: This material may burn, but will not ignite readily. If container is not properly cooled, it can rupture in the heat of a fire.

Hazardous Combustion Products: Combustion may yield smoke, carbon monoxide, and other products of incomplete combustion. Oxides of sulfur, nitrogen or phosphorus may also be formed.

Special protective actions for firefighters: For fires beyond the initial stage, emergency responders in the immediate hazard area should wear protective clothing. When the potential chemical hazard is unknown, in enclosed or confined spaces, a self contained breathing apparatus should be worn. In addition, wear other appropriate protective equipment as conditions warrant (see Section 8).

Isolate the hazard area and deny entry to unnecessary and unprotected personnel. Stop spill/release if it can be done safely. Move undamaged containers from immediate hazard area if it can be done safely. Water spray may be useful in minimizing or dispersing vapors and to protect personnel. Cool equipment exposed to fire with water, if it can be done safely. Avoid spreading burning liquid with water used for cooling purposes.

See Section 9 for Flammable Properties including Flash Point and Flammable (Explosive) Limits

SECTION 6: Accidental release measures

Personal precautions, protective equipment and emergency procedures: This material may burn, but will not ignite readily. Keep all sources of ignition away from spill/release. Stay upwind and away from spill/release. Avoid direct contact with material. For large spillages, notify persons down wind of the spill/release, isolate immediate hazard area and keep unauthorized personnel out. Wear appropriate protective equipment, including respiratory protection, as conditions warrant (see Section 8). See Sections 2 and 7 for additional information on hazards and precautionary measures.

Environmental Precautions: Stop and contain spill/release if it can be done safely. Prevent spilled material from entering sewers, storm drains, other unauthorized drainage systems, and natural waterways. Use water sparingly to minimize environmental contamination and reduce disposal requirements. If spill occurs on water notify appropriate authorities and advise shipping of any hazard. Spills into or upon navigable waters, the contiguous zone, or adjoining shorelines that cause a sheen or discoloration on the surface of the water, may require notification of the National Response Center (phone number 800-424-8802).

Methods and material for containment and cleaning up: Notify relevant authorities in accordance with all applicable regulations. Immediate cleanup of any spill is recommended. Dike far ahead of spill for later recovery or disposal. Absorb spill with inert material such as sand or vermiculite, and place in suitable container for disposal. If spilled on water remove with appropriate methods (e.g. skimming, booms or absorbents). In case of soil contamination, remove contaminated soil for remediation or disposal, in accordance with local regulations.

Recommended measures are based on the most likely spillage scenarios for this material; however local conditions and regulations may influence or limit the choice of appropriate actions to be taken. See Section 13 for information on appropriate disposal.

SECTION 7: Handling and storage

Precautions for safe handling: Keep away from flames and hot surfaces. Wash thoroughly after handling. Use good personal hygiene practices and wear appropriate personal protective equipment (see section 8). Spills will produce very slippery surfaces. High pressure injection of hydrocarbon fuels, hydraulic oils or greases under the skin may have serious consequences even though no symptoms or injury may be apparent. This can happen accidentally when using high pressure equipment such as high pressure grease guns, fuel injection apparatus or from pinhole leaks in tubing of high pressure hydraulic oil equipment.

Do not enter confined spaces such as tanks or pits without following proper entry procedures such as ASTM D-4276 and 29CFR 1910.146. Do not wear contaminated clothing or shoes.

Conditions for safe storage: Keep container(s) tightly closed and properly labeled. Use and store this material in cool, dry, well-ventilated area away from heat and all sources of ignition. Store only in approved containers. Keep away from any incompatible material (see Section 10). Protect container(s) against physical damage.

"Empty" containers retain residue and may be dangerous. Do not pressurize, cut, weld, braze, solder, drill, grind, or expose such containers to heat, flame, sparks, or other sources of ignition. They may explode and cause injury or death. "Empty" drums should be completely drained, properly bunged, and promptly shipped to the supplier or a drum reconditioner. All containers should be disposed of in an environmentally safe manner and in accordance with governmental regulations. Before working on or in tanks which contain or have contained this material, refer to OSHA regulations, ANSI Z49.1, and other references pertaining to cleaning, repairing, welding, or other contemplated operations.

SECTION 8: Exposure controls/personal protection

Chemical Name	ACGIH	OSHA	Phillips 66
Distillates, petroleum, hydrotreated heavy paraffinic	---	---	TWA: 5 mg/m ³ STEL: 10 mg/m ³ as Oil Mist, if Generated

Note: State, local or other agencies or advisory groups may have established more stringent limits. Consult an industrial hygienist or similar professional, or your local agencies, for further information.

Engineering controls: If current ventilation practices are not adequate to maintain airborne concentrations below the established exposure limits, additional engineering controls may be required.

Eye/Face Protection: The use of eye/face protection is not normally required; however, good industrial hygiene practice suggests the use of eye protection that meets or exceeds ANSI Z.87.1 whenever working with chemicals.

Skin/Hand Protection: The use of skin protection is not normally required; however, good industrial hygiene practice suggests the use of gloves or other appropriate skin protection whenever working with chemicals. Suggested protective materials: Nitrile

Respiratory Protection: Where there is potential for airborne exposure above the exposure limit a NIOSH certified air purifying respirator equipped with R or P95 filters may be used.

A respiratory protection program that meets or is equivalent to OSHA 29 CFR 1910.134 and ANSI Z88.2 should be followed whenever workplace conditions warrant a respirator's use. Air purifying respirators provide limited protection and cannot be used in atmospheres that exceed the maximum use concentration (as directed by regulation or the manufacturer's instructions), in oxygen deficient (less than 19.5 percent oxygen) situations, or under conditions that are immediately dangerous to life and health (IDLH).

Suggestions provided in this section for exposure control and specific types of protective equipment are based on readily available information. Users should consult with the specific manufacturer to confirm the performance of their protective equipment. Specific situations may require consultation with industrial hygiene, safety, or engineering professionals.

SECTION 9: Physical and chemical properties

Note: Unless otherwise stated, values are determined at 20°C (68°F) and 760 mm Hg (1 atm). Data represent typical values and are not intended to be specifications.

Appearance: Amber, Transparent

Physical Form: Liquid
1010

Odor: Petroleum

Odor Threshold: No data

pH: Not applicable

Vapor Density (air=1): >1

air): No data

% in air): No data

Evaporation Rate (nBuAc=1): No data

Particle Size: Not applicable

Percent Volatile: No data

Flammability (solid, gas): Not applicable

Solubility in Water: Negligible

Flash Point: > 302 °F / > 150 °C (ASTM D93)

Test Method: Pensky-Martens Closed Cup (PMCC), ASTM D93, EPA

Initial Boiling Point/Range: No data

Vapor Pressure: <1 mm Hg

Partition Coefficient (n-octanol/water) (Kow): No data

Melting/Freezing Point: No data **Upper Explosive Limits (vol % in**

Auto-ignition Temperature: No data **Lower Explosive Limits (vol**

Decomposition Temperature: No data

Specific Gravity (water=1): 0.85-0.89 @ 60°F (15.6°C)

Bulk Density: No data

Viscosity: 4.0 - 25 cSt @ 100°C; 21 - 345 cSt @ 40°C

Pour Point: < 10 °F / < -12 °C

SECTION 10: Stability and reactivity

Reactivity: Not chemically reactive.

Chemical stability: Stable under normal ambient and anticipated conditions of use.

Possibility of hazardous reactions: Hazardous reactions not anticipated.

Conditions to avoid: Extended exposure to high temperatures can cause decomposition. Avoid all possible sources of ignition.

Incompatible materials: Avoid contact with strong oxidizing agents and strong reducing agents.

Hazardous decomposition products: Not anticipated under normal conditions of use.

SECTION 11: Toxicological information

Acute Toxicity	Hazard	Additional Information	LC50/LD50 Data
Inhalation	Unlikely to be harmful		>5 mg/L (mist, estimated)
Dermal	Unlikely to be harmful		> 2 g/kg (estimated)
Oral	Unlikely to be harmful		> 5 g/kg (estimated)

Information on Toxicological Effects Substance / Mixture

Aspiration Hazard: Not expected to be an aspiration hazard.

Skin Corrosion/Irritation: Not expected to be irritating.

Serious Eye Damage/Irritation: Not expected to be irritating.

Skin Sensitization: No information available on the mixture, however none of the components have been classified for skin sensitization (or are below the concentration threshold for classification).

Respiratory Sensitization: No information available.

Specific Target Organ Toxicity (Single Exposure): No information available on the mixture, however none of the components have been classified for target organ toxicity (or are below the concentration threshold for classification).

Specific Target Organ Toxicity (Repeated Exposure): No information available on the mixture, however none of the components have been classified for target organ toxicity (or are below the concentration threshold for classification).

Carcinogenicity: No information available on the mixture, however none of the components have been classified for carcinogenicity (or are below the concentration threshold for classification).

Germ Cell Mutagenicity: No information available on the mixture, however none of the components have been classified for germ cell mutagenicity (or are below the concentration threshold for classification).

Reproductive Toxicity: No information available on the mixture, however none of the components have been classified for reproductive toxicity (or are below the concentration threshold for classification).

Information on Toxicological Effects of Components

Distillates, petroleum, hydrotreated heavy paraffinic

Carcinogenicity: This oil has been highly refined by a variety of processes to reduce aromatics and improve performance characteristics. It meets the IP-346 criteria of less than 3 percent PAH's and is not considered a carcinogen by the International Agency for Research on Cancer.

SECTION 12: Ecological information

Toxicity: All acute aquatic toxicity studies on samples of lubricant base oils show acute toxicity values greater than 100

**GHS Classification: No
classified hazards**

mg/L for

invertebrates, algae and fish. These tests were carried out on water accommodated fractions and the results are consistent with the predicted aquatic toxicity of these substances based on their hydrocarbon compositions.

Persistence and Degradability: The hydrocarbons in this material are not readily biodegradable, but since they can be degraded by microorganisms, they are regarded as inherently biodegradable.

Bioaccumulative Potential: Log Kow values measured for the hydrocarbon components of this material are greater than 5.3, and therefore regarded as having the potential to bioaccumulate. In practice, metabolic processes may reduce bioconcentration.

Mobility in Soil: Volatilization to air is not expected to be a significant fate process due to the low vapor pressure of this material. In water, base oils will float and spread over the surface at a rate dependent upon viscosity. There will be significant removal of hydrocarbons from the water by sediment adsorption. In soil and sediment, hydrocarbon components will show low mobility with adsorption to sediments being the predominant physical process. The main fate process is expected to be slow biodegradation of the hydrocarbon constituents in soil and sediment.

Other adverse effects: None anticipated.

SECTION 13: Disposal considerations

The generator of a waste is always responsible for making proper hazardous waste determinations and needs to consider state and local requirements in addition to federal regulations. This material, if discarded as produced, would not be a federally regulated RCRA "listed" hazardous waste and is not believed to exhibit characteristics of hazardous waste. See Sections 7 and 8 for information on handling, storage and personal protection and Section 9 for physical/chemical properties. It is possible that the material as produced contains constituents which are not required to be listed in the SDS but could affect the hazardous waste determination. Additionally, use which results in chemical or physical change of this material could subject it to regulation as a hazardous waste. This material under most intended uses would become "Used Oil" due to contamination by physical or chemical impurities. Whenever possible, Recycle used oil in accordance with applicable federal and state or local regulations. Container contents should be completely used and containers should be emptied prior to discard.

SECTION 14: Transport information

U.S. Department of Transportation (DOT) UN Number: Not regulated

UN proper shipping name: None

Transport hazard class(es):None **Packing Group:** None

Environmental Hazards: This product does not meet the DOT/UN/IMDG/IMO criteria of a marine pollutant

Special precautions for user: If shipped by land in a packaging having a capacity of 3,500 gallons or more, the provisions of 49 CFR, Part 130 apply. (Contains oil)

Transport in bulk according to Annex II of MARPOL 73/78 and the IBC Code: Not applicable

SECTION 15: Regulatory information

CERCLA/SARA - Section 302 Extremely Hazardous Substances and TPQs (in pounds):

This material does not contain any chemicals subject to the reporting requirements of SARA 302 and 40 CFR 372.

CERCLA/SARA - Section 311/312 (Title III Hazard

Categories) Acute Health Hazard: No
Chronic Health Hazard: No
Fire Hazard: No
Pressure Hazard: No
Reactive Hazard: No

CERCLA/SARA - Section 313 and 40 CFR 372:

This material does not contain any chemicals subject to the reporting requirements of SARA 313 and 40 CFR 372.

EPA (CERCLA) Reportable Quantity (in pounds):

This material does not contain any chemicals with CERCLA Reportable Quantities.

California Proposition 65:

This material does not contain any chemicals which are known to the State of California to cause cancer, birth defects or other reproductive harm at concentrations that trigger the warning requirements of California Proposition 65.

International Hazard Classification

Canada:

This product has been classified in accordance with the hazard criteria of the Hazardous Products Regulations (SOR/2015-17) and the SDS contains all the information required by the Regulations.

International Inventories

All components are either listed on the US TSCA Inventory, or are not regulated under TSCA. All components are either on the DSL, or are exempt from DSL listing requirements.

U.S. Export Control Classification Number: EAR99

SECTION 16: Other information

Issue Date:	Previous Issue Date:	SDS Number	Status:
28-Jun-2016	23-Jun-2016	LBPH814637	FINAL

Revised Sections or Basis for Revision: New SDS

Guide to Abbreviations:

ACGIH = American Conference of Governmental Industrial Hygienists; CASRN = Chemical Abstracts Service Registry Number; CEILING = Ceiling Limit (15 minutes); CERCLA = The Comprehensive Environmental Response, Compensation, and Liability Act; EPA = Environmental Protection Agency; GHS = Globally Harmonized System; IARC = International Agency for Research on Cancer; INSHT = National Institute for Health and Safety at Work; IOPC = International Oil Pollution Compensation; LEL = Lower Explosive Limit; NE = Not Established; NFPA = National Fire Protection Association; NTP = National Toxicology Program; OSHA = Occupational Safety and Health Administration; PEL = Permissible Exposure Limit (OSHA); SARA = Superfund Amendments and Reauthorization Act; STEL = Short Term Exposure Limit (15 minutes); TLV = Threshold Limit Value (ACGIH); TWA = Time Weighted Average (8 hours); UEL = Upper Explosive Limit; WHMIS = Worker Hazardous Materials Information System (Canada)

Disclaimer of Expressed and implied Warranties:

The information presented in this Safety Data Sheet is based on data believed to be accurate as of the date this Safety Data Sheet was prepared. HOWEVER, NO WARRANTY OF MERCHANTABILITY, FITNESS FOR ANY PARTICULAR PURPOSE, OR ANY OTHER WARRANTY IS EXPRESSED OR IS TO BE IMPLIED REGARDING THE ACCURACY OR COMPLETENESS OF THE INFORMATION PROVIDED ABOVE, THE RESULTS TO BE OBTAINED FROM THE USE OF THIS INFORMATION OR THE PRODUCT, THE SAFETY OF THIS PRODUCT, OR THE HAZARDS RELATED TO ITS USE. No responsibility is assumed for any damage or injury resulting from abnormal use or from any failure to adhere to recommended practices. The information provided above, and the product, are furnished on the condition that the person receiving them shall make their own determination as to the suitability of the product for their particular purpose and on the condition that they assume the risk of their use. In addition, no authorization is given nor implied to practice any patented invention without a license.

Section IV

Installation

A. Set-up

Install the booster either vertically or horizontally in its operating position. Check the hydraulic oil level through the translucent fluid reservoir. Add oil as necessary, through the breather port. Note-If the booster is mounted vertically, the oil filler port must be on top. Replace the fill port plug with the breather plug, but not until the booster is mounted in its final position.

Attach the control valve to the booster. Before operating the booster check all gages, valves, hoses, and fittings for proper installation. The booster is equipped with an SAE 4 O-ring port on the outlet plate. Use only an SAE 4 O-ring style fitting to connect to this port. **Do not** use pipe joint compound, thread sealing tape, or other sealing materials with this type of connection.

During the set-up of the clamping system, set the input air pressure to the minimum pressure required to operate the system components. Cycle the system at low pressure to expose any errors in the installation, such as, loose connections or clamping device positioning. After checking the system at low pressure, re-set the inlet pressure to operate the system at the desired pressure.

B. Removing Air From The System

Sluggish or inconsistent device motion is usually an indication that there is air in the hydraulic system. Remove as much air from the system as possible using the following procedures.

1. Elevate the booster to a height greater than any device in the system and cycle the control valves several times.
2. Starting with the connection that is either farthest from the booster, or highest in the system, carefully loosen it only enough to allow oil to escape. **Do not** remove the fitting under hydraulic pressure as personal injury may occur. The appearance of bubbles or unclear oil indicates that air is being pushed out of the system. When the oil is clear, retighten the fitting. Tighten the fitting before retracting the air piston or air will be drawn back into the system. Check for normal system operation. Repeat this procedure as needed with adjacent fittings closer to the booster or lower in the system.
3. If the system proves to be particularly difficult to bleed, install a bleeder valve in the system.

WARNING

Never touch an escaping high-pressure hydraulic oil stream. Failure to comply with this warning may result in serious personal injury.

Section V

Control Valves

Vektek boosters are available in four different control valve configurations (or with no control valve).

1. Manual, five port (two exhaust), two position
2. 24 Volt DC, five port (two exhaust), two position, single solenoid
3. 110 Volt AC, five port (two exhaust), two position, single solenoid
4. Pneumatic Pilot, five port (two exhaust), two position, single pilot

Each booster is shipped with the breather plug, mounting kit and control valve unassembled. Upon receipt of the booster, attach the control valve to the booster with the two cap screws (item 1) provided. To provide clearance for the control valve, the spacer (item 9) must be placed between the valve body and the end plate. Assemble the two pneumatic elbow fittings (items 10b) to the booster. Install one of them in the 1/8 NPT port on the periphery of the separator plate. Install the other one in the 1/8 NPT port on the end plate (below the control valve). Connect the plastic tubing (item 10c) to the fittings as illustrated below.

A booster assembly using the 24 volt DC or 110 volt AC valve is provided plumbed in the configuration as shown below. This configuration is such that when no electrical power is provided to the valve solenoid the booster will create hydraulic pressure. To reverse this condition so that when no electrical power is provided to the valve solenoid the booster will not create hydraulic pressure, swap the plastic tubing (items 10c) connections at the valve.

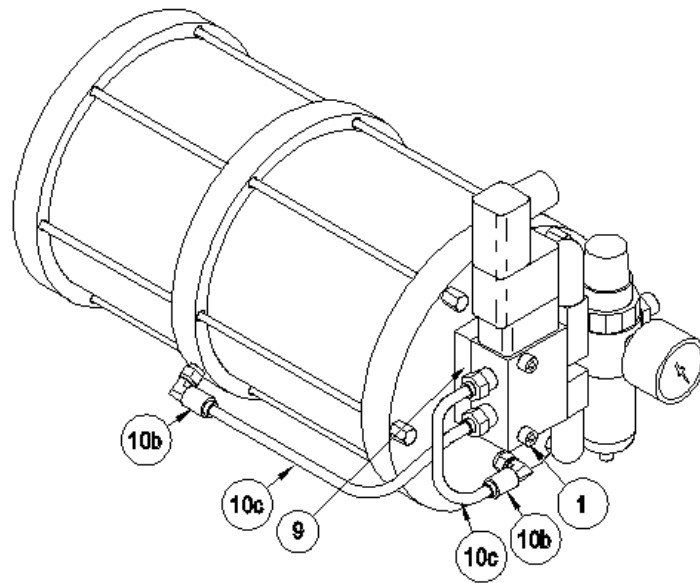

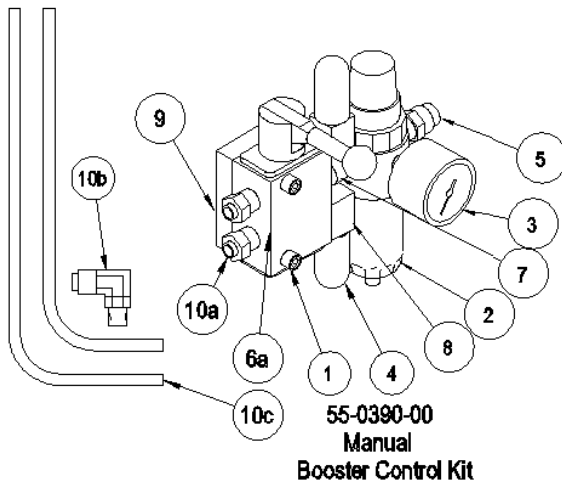

Item	Qty	Part Number	Description
1	2	21-4100-23	Screw, Cap, 1/4-28 x 2
2	1	50-0440-00	Filter/Regulator, 125 psi
3	1	50-2010-00	Gauge, Pressure, 160 psi
4	2	50-3030-00	Muffler, Pneumatic, 1/4 NPT
5	1	50-4045-00	Valve, Check, 1/4 NPT
6a	1	50-4742-00	Valve, Pneu, 5/2, Manual
6b	1	50-4744-00	Valve, Pneu, 5/2, 120VAC
6c	1	50-4744-01	Valve, Pneu, 5/2, 24VDC
6d	1	50-4742-01	Valve, Pneu, 5/2, Pilot
7	1	50-6030-01	Nipple, Pipe, 1/4 NPT
8	1	50-6040-02	Elbow, Street, Pipe, 1/4 NPT
9	1	85-5001-91	Spacing, Mounting, Valve
10	1	62-5570-00	Kit, Supply, Air (Not Shown)
10a*	2	P3-0238-00	Connector, Straight, 1/4
10b*	2	P3-0131-00	Connector, Elbow, 1/4
10c*	2	50-5000-07	Tubing, 3/8

*Included in 62-5570-00 Air Supply Kit

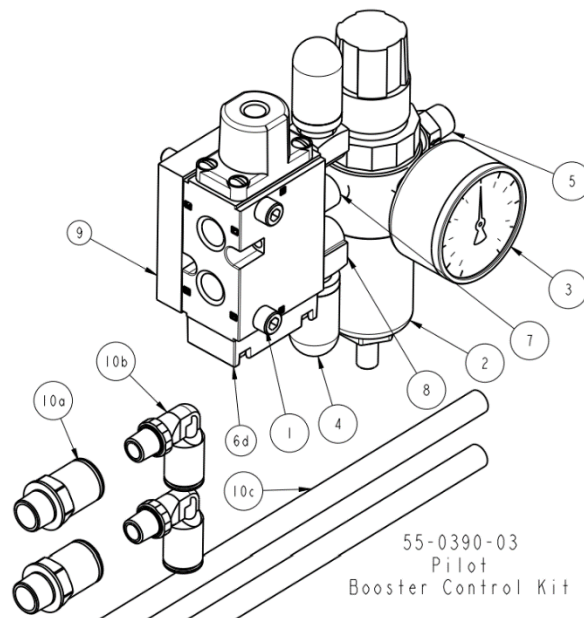
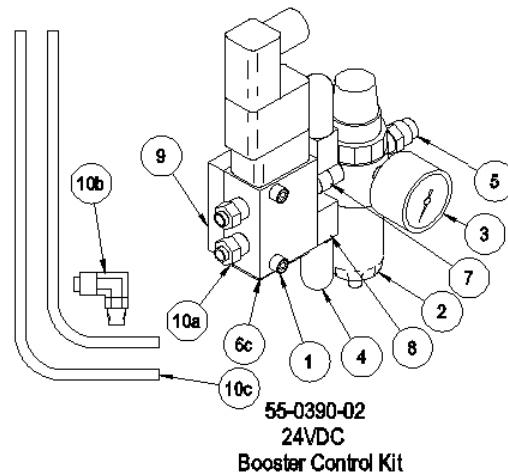
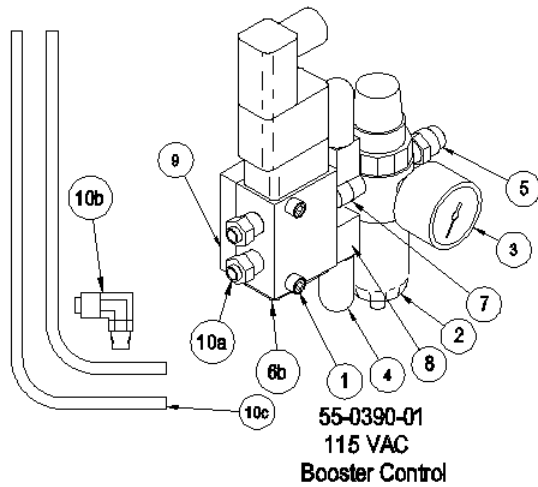

Section VI

Maintenance

Warning

Disconnect the air supply to the booster **before** performing any maintenance. **Do not** connect or disconnect any device from the hydraulic circuit while it is pressurized. Check all gauges to verify that all system pressure has been relieved. Failure to follow this warning may result in property damage or personal injury.

Notice

Always clean dirt and debris from the booster before any maintenance is performed.

Notice

Never mix different grades of oil. Completely drain and flush the system before filling with the new grade.

Booster Maintenance

1.0 Daily

- a. Check the hydraulic oil level through the translucent fluid reservoir. The oil level should be between the two marks on the separator plate. If the booster is mounted vertically, the oil level should be within one inch of the top plate. Add oil as necessary through the breather port.
- b. Check hoses, tubing, fittings, and quick couplers for damage and wear. Replace as necessary.

2.0 Monthly

- a. If the booster is equipped with a Vekttek control valve, check the air filter in the bowl. Clean the filter as needed.

Notice

Do not operate the booster without a filtered air supply. Doing so will void the product warranty.

3.0 Semiannually

- a. Change oil.
 - i. Drain the oil through the reservoir drain plug.
 - ii. Refill the booster pump with the correct grade of oil, to the appropriate level.

Pneumatic Division
 Richland, Michigan 49083
 269-629-5000

Installation & Service Instructions
 IS-B548

B548 Miniature Integral
Filter / Regulator Series

ISSUED: February, 2005

Doc. #ISB548, ECN #050142, Rev. 1

⚠ WARNING

To avoid unpredictable system behavior that can cause personal injury and property damage:

- Disconnect electrical supply (when necessary) before installation, servicing, or conversion.
- Disconnect air supply and depressurize all air lines connected to this product before installation, servicing, or conversion.
- Operate within the manufacturer's specified pressure, temperature, and other conditions listed in these instructions.
- Medium must be moisture-free if ambient temperature is below freezing.
- Service according to procedures listed in these instructions.
- Installation, service, and conversion of these products must be performed by knowledgeable personnel who understand how pneumatic products are to be applied.
- After installation, servicing, or conversion, air and electrical supplies (when necessary) should be connected and the product tested for proper function and leakage. If audible leakage is present, or the product does not operate properly, do not put into use.
- Warnings and specifications on the product should not be covered by paint, etc. If masking is not possible, contact your local representative for replacement labels.

⚠ CAUTION

Polycarbonate bowls, being transparent and tough, are ideal for use with Filters and Lubricators. They are suitable for use in normal industrial environments, but should not be located in areas where they could be subjected to direct sunlight, an impact blow, nor temperatures outside of the rated range. As with most plastics, some chemicals can cause damage. Polycarbonate bowls should not be exposed to chlorinated hydrocarbons, ketones, esters and certain alcohols. They should not be used in air systems where compressors are lubricated with fire-resistant fluids such as phosphate ester and diester types.

Metal bowls are recommended where ambient and/or media conditions are not compatible with polycarbonate bowls. Metal bowls resist the action of most such solvents, but should not be used where strong acids or bases are present or in salt laden atmospheres. Consult the factory for specific recommendations where these conditions exist.

TO CLEAN POLYCARBONATE BOWLS USE MILD SOAP AND WATER ONLY! DO NOT use cleansing agents such as acetone, benzene, carbon tetrachloride, gasoline, toluene, etc., which are damaging to this plastic.

⚠ WARNING

**Product rupture can cause serious injury.
 Do not connect regulator to bottled gas.
 Do not exceed maximum primary pressure rating.**

Introduction

Follow these instructions when installing, operating, or servicing the product.

Application Limits

These products are intended for use in general purpose compressed air systems only.

Maximum Recommended Pressure Drop:

	kPa	PSIG	bar
Particulate Filter	70	10	0.7
Operating Pressure Maximum	kPa	PSIG	bar
Polycarbonate Bowl	1034	150	10.3
Metal Bowl	2068	300	21.0
Piston Drain	1207	175	12.0

Operating Temperature Range

Polycarbonate Bowl	Max. 49°C (120°F)
Metal Bowl	Max. 82°C (180°F)
Piston Drain	Max. 65.6°C (150°F)

Symbols

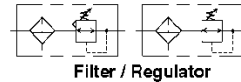

Installation

1. The Filter / Regulator should be installed with reasonable accessibility for service whenever possible – repair service kits are available. Keep pipe or tubing lengths to a minimum with inside clean and free of dirt and chips. Pipe joint compound should be used sparingly and applied only to the male pipe – never into the female port. Do not use PTFE tape to seal pipe joints – pieces have a tendency to break off and lodge inside the unit, possibly causing malfunction. Also, new pipe or hose should be installed between the Filter / Regulator and equipment being protected.
2. The upstream pipe work must be clear of accumulated dirt and liquids.
3. Select a Filter / Regulator location as close as possible to the equipment being protected.
4. Install Filter / Regulator so that air flows into port labelled "IN" on body.

⚠ WARNING

FAILURE OR IMPROPER SELECTION OR IMPROPER USE OF THE PRODUCTS AND/OR SYSTEMS DESCRIBED HEREIN OR RELATED ITEMS CAN CAUSE DEATH, PERSONAL INJURY AND PROPERTY DAMAGE.

This document and other information from The Company, its subsidiaries and authorized distributors provide product and/or system options for further investigation by users having technical expertise. It is important that you analyze all aspects of your application, including consequences of any failure and review the information concerning the product or systems in the current product catalog. Due to the variety of operating conditions and applications for these products or systems, the user, through its own analysis and testing, is solely responsible for making the final selection of the products and systems and assuring that all performance, safety and warning requirements of the application are met.

The products described herein, including without limitation, product features, specifications, designs, availability and pricing, are subject to change by The Company and its subsidiaries at any time without notice.

EXTRA COPIES OF THESE INSTRUCTIONS ARE AVAILABLE FOR INCLUSION IN EQUIPMENT / MAINTENANCE MANUALS THAT UTILIZE THESE PRODUCTS. CONTACT YOUR LOCAL REPRESENTATIVE.

B548 Miniature Series Integral Filter / Regulator

IS-B548

5. Install Filter / Regulator vertically with the bowl drain mechanism at the bottom. Free moisture will thus drain into the sump ("quiet zone") at the bottom of the bowl.
6. Gauge ports are located on both sides of the Filter / Regulator body for your convenience. It is necessary to install a gauge or socket pipe plugs into each port during installation.

Operation

1. Both free moisture and solids are removed automatically by the filter.
2. Manual drain filters must be drained regularly before the separated moisture and oil reaches the bottom of the Baffle or End Cap.
3. The Filter Element should be removed and replaced when pressure differential across the filter is 69 kPa (10 PSIG).
4. Before turning on the air supply, disengage the Adjusting Knob by pulling upward. Turn Adjusting Knob counterclockwise until the compression is released from the Pressure Control Spring.
5. Then turn Knob clockwise and adjust regulator to desired downstream pressure. This permits pressure to build up slowly in the downstream line.
6. To decrease regulated pressure settings, always reset from a pressure lower than the final setting required. Example, lowering the secondary pressure from 550 to 410 kPa (80 to 60 PSIG) is best accomplished by dropping the secondary pressure to 350 kPa (50 PSIG), then adjusting upward to 410 kPa (60 PSIG).
7. When desired secondary pressure setting has been reached, push the Knob down to lock this pressure setting.

Service

⚠ Caution: Disconnect or shut off air supply and exhaust the primary and secondary pressures before servicing unit. Turning the adjusting knob counterclockwise does not vent downstream pressure on non-relieving regulators. Downstream pressure must be vented before servicing regulator.

⚠ Caution: Grease packets are supplied with kits for lubrication of seals. Use only mineral based grease or oils. Do not use synthetic oils such as esters. Do not use silicones.

Note: After servicing unit, turn on air supply and adjust regulator to the desired downstream pressure. Check unit for leaks. If leakage occurs, do not operate - conduct repairs and retest.

Servicing Filter Element - (Refer to Figure 1)

1. Unscrew and remove Bowl.
2. Unscrew the Element Retainer from Body and then remove Element.
3. Clean all internal parts and bowl before reassembling.
4. Install new element. **IMPORTANT:** The Filter / Regulator will not operate properly if the Deflector is not installed properly. The Deflector must be installed between the Element Retainer and the Filter Body.
5. Attach Element Retainer and finger tighten firmly.
6. Replace Bowl Seal. Lightly lubricate new seal to assist with retaining it in position.
7. Install Bowl into Body and tighten; hand tight, plus 1/4 turn.

Servicing Regulator - (Refer to Figure 1)

1. Disengage the Adjusting Knob by pulling upward. Turn Adjusting Knob counterclockwise until the compression is released from the Pressure Control Spring.
2. Remove the Bonnet and Bowl assemblies by unscrewing the Bonnet and Bowl from the body.
3. Remove Diaphragm Assembly from Bonnet Assembly.
4. Remove Element Retainer, Filter Element, Poppet Assembly, Poppet Return Spring.
5. Clean and carefully inspect parts for wear or damage. Wipe parts, clean with soapy water or denatured alcohol **but do not use denatured alcohol on plastic bowl or sight gauge.** If using compressed air to blow dry, be sure to wear appropriate eye protection. If replacement is necessary, use parts from service kits. Clean Bowl.

6. Lubricate O-rings with grease found in service kits.
7. Install Filter Element onto the Element Retainer and firmly tighten.
8. Install Poppet Return Spring, Poppet Assembly, and Element Retainer. **IMPORTANT:** The Filter / Regulator will not operate properly if the Deflector is not installed properly. The Deflector must be installed between the Element Retainer and Filter Body.
9. Install Diaphragm Assembly into Body Assembly. Assemble Bonnet Assembly onto Body and tighten per Figure 1.
10. Install Bowl into Body and tighten, hand tight, plus 1/4 turn.

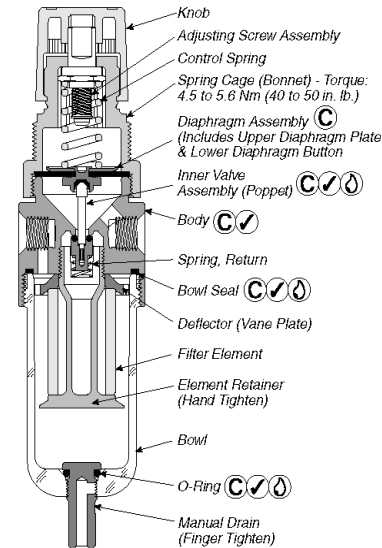

Figure 1

- (L) Lightly grease with provided lubricant.
- (G) Inspect for nicks, scratches, and surface imperfections.
- (C) If present, reduced service life is probable and future replacement should be planned.
- (C) Clean with lint-free cloth.

Service / Parts Kits Available

Description	B548 (1/8" & 1/4")
Bowl Kits	
Polycarbonate	BK504Y
Polycarbonate (with Piston Drain)	BK504SY
Zinc	BK505Y
Zinc (with Piston Drain)	BK505SY
Bowl Seal	GSK-504Z101
Cage Kit	
Standard	CKR364Y
"T" Option	CKR364T
Filter Element (5 Micron)	EK504VY
Filter Element (20 Micron)	EK504Y
Gauge, 0 to 60 (0 to 4 bar)	274Z60S
Gauge, 0 to 160 (0 to 11 bar)	274Z160S
Mounting Bracket	SA161X57
Piston Drain (Max. Pressure 150 PSIG)	RK504SY
Panel Mount Nut	R05X51
Regulator Repair Kit (Relieving)	RK549Y
Regulator Repair Kit (Non-Relieving)	RK548Y
Spring, 0-25 PSIG (0 to 1.7 bar)	SPR-375-1
Spring, 0-60 PSIG (0 to 4 bar)	SPR-376
Spring, 0-125 PSIG (0 to 8.6 bar)	SPR-377
Deflector (Vane Plate)	504Z75
Return Spring	SPR-80
Element Retainer	F504-0491P

Section VII

Trouble Shooting

Symptoms:	Cause:	Solution:
Erratic device operation:	<ol style="list-style-type: none"> 1. Air in the hydraulic system 2. Low oil level. 	<ol style="list-style-type: none"> 1. See Section IV B for bleeding. 2. Check oil level-add as needed.
Booster Piston Does Not move when the valve is actuated:	<ol style="list-style-type: none"> 1. No air supply. 2. Air pressure set too low. 3. Control valve is not working. 	<ol style="list-style-type: none"> 1. Connect or turn on air supply. 2. Adjust regulator as needed 3. Determine problem, repair or replace.
Hydraulic pressure will not build to the expected level:	<ol style="list-style-type: none"> 1. Low oil level. 2. Low air inlet pressure 3. Damaged sealing components. 	<ol style="list-style-type: none"> 1. Check oil level. Add as needed. 2. Adjust air regulator as needed. 3. Locate damaged components and replace.
Pressure builds, but will not hold:	<ol style="list-style-type: none"> 1. Damaged sealing components. 2. Control valve is leaking. 	<ol style="list-style-type: none"> 1. Locate damaged components and replace. 2. Locate defect, repair or replace.
The pneumatic piston will not retract when the control valve is actuated for the return stroke:	<ol style="list-style-type: none"> 1. The control vale is faulty. 2. Booster is damaged internally. 	<ol style="list-style-type: none"> 1. Determine cause, repair or replace. 2. Return for Service

If the procedures listed above do not remedy the symptoms,
contact Vektek at 1-800-992-0236.

Section VIII

Basic Booster Parts List

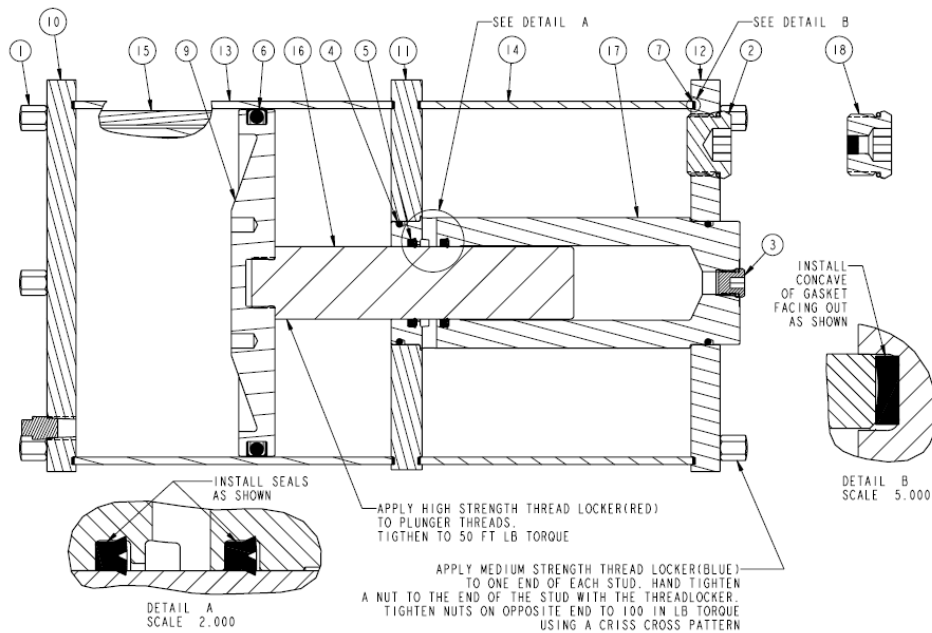

Booster Ratio:			54:1	40:1	22:1	11:1
Item	Qty	Part Description	55-0114-04 55-0224-16 55-0224-17 55-0224-18 55-0224-19	55-0114-02 55-0214-16 55-0214-17 55-0214-18 55-0214-19	55-0104-00 55-0204-16 55-0204-17 55-0204-18 55-0204-19	55-0184-00 55-0284-16 55-0284-17 55-0284-18 55-0284-19
1	12	Nut, Blind, 1/4-28	21-4200-04	21-4200-04	21-4200-04	21-4200-04
2	1	Plug, SAE 12	30-6011-12	30-6011-12	30-6011-12	30-6011-12
3	1	Plug, SAE 4	30-6011-44	30-6011-44	30-6011-44	30-6011-44
4	2	O-ring	39-0010-35*	39-0010-35*	39-0010-35*	39-0010-35*
4	2	O-ring, FKM	39-V010-15**	39-V010-15**	39-V010-15**	39-V010-15**
5	2	Seal, Loaded Lip	39-0110-45*	39-0110-63*	39-0520-29*	39-0110-74*
5	2	Seal, Loaded Lip, FKM	39-0120-05**	39-V110-63**	39-0520-15**	39-V110-74**
6	1	Seal, Piston	39-0130-06*	39-0130-06*	39-0130-06*	39-0130-06*
7	4	Gasket	39-0210-05*	39-0210-05*	39-0210-05*	39-0210-05*
7	4	Gasket, FKM	39-V210-05**	39-V210-05**	39-V210-05**	39-V210-05**
8	2	Plug, 1/8 NPT	68-0001-18	68-0001-18	68-0001-18	68-0001-18
9	1	Piston, Booster	85-5010-01	85-5010-01	85-5010-01	85-5010-01
10	1	Plate, Base, Booster	85-5010-41	85-5010-41	85-5010-41	85-5010-41
11	1	Plate, Separator, Booster	85-5010-51	85-5010-51	85-5010-51	85-5010-51
12	1	Plate, Head, Booster	85-5010-61	85-5010-61	85-5010-61	85-5010-61
13	1	Chamber, Air	85-5010-82	85-5010-82	85-5010-82	85-5010-82
14	1	Reservoir, Oil	85-5010-83	85-5010-83	85-5010-83	85-5010-83
15	6	Stud, Booster	85-5011-01	85-5011-01	85-5011-01	85-5011-01
16	1	Plunger, Booster	85-5040-30	85-5010-31	85-5000-30	85-5030-30
17	1	Barrel, Pressure, Booster	85-5040-90	85-5010-91	85-5000-90	85-5030-90
18	1	Breather, SAE 12	95-5001-90	95-5001-90	95-5001-90	95-5001-90
*	NA	Kit, Seal	60-5500-66	60-5500-61	60-5500-63	60-5500-65
**	NA	Kit, Seal, FKM	6V5500-66	6V-5500-61	6V-5500-63	6V-5500-65

55-0390-06 Booster Mounting Kit			
Item	Qty	Part Number	Description
1	4	21-4100-24	Flat Head Cap Screw
2	2	85-5400-05	Mounting Bracket

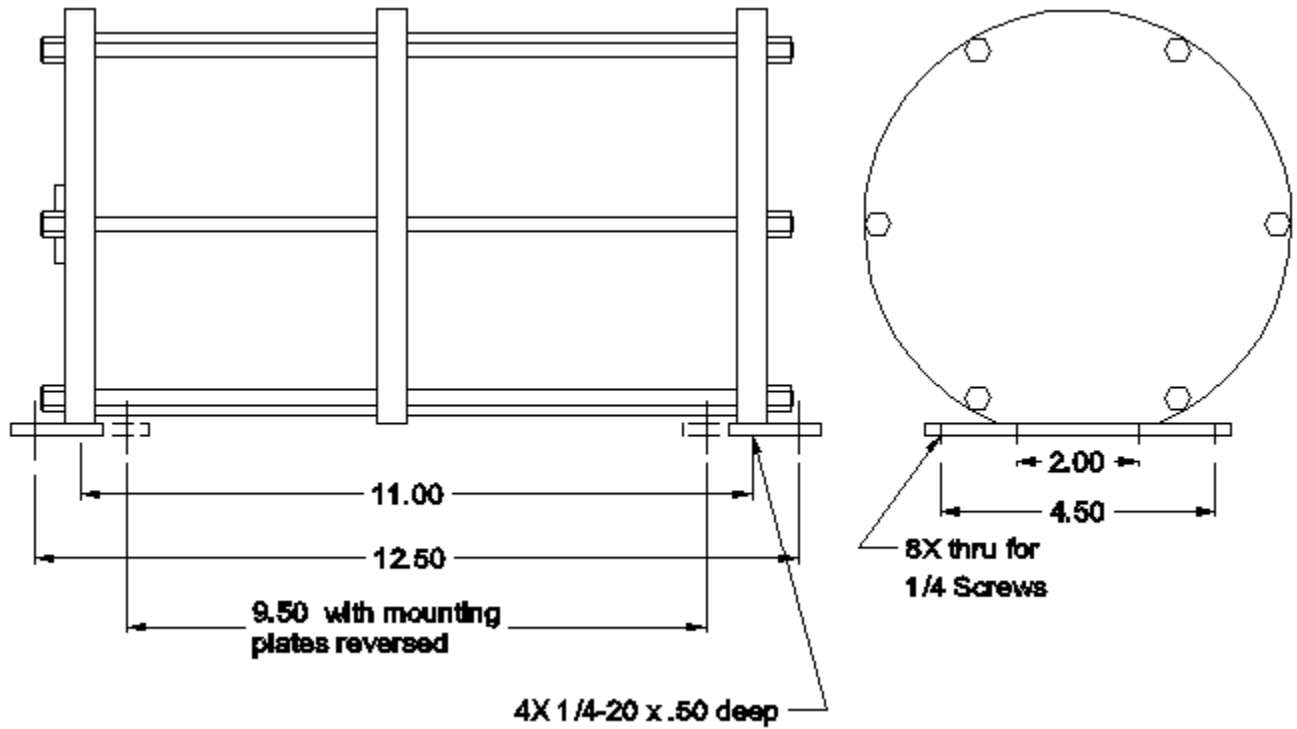
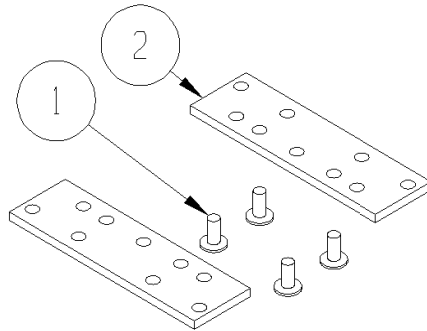

Section IX

Warranty and Return Information

Warranty

Vekttek, Inc. warrants each VektorFlo® product to the original purchaser, unless end user assignment is made at the time of purchase. Each product is warranted against defects in workmanship and materials for one year from the date of delivery.

This warranty is limited to the repair or replacement of any product(s) that are found, by Vekttek, to be defective. This warranty does not cover ordinary wear and tear, abuse, misapplication, overloading, excessive flow rates, altered products or the use of improper fluids.

This warranty is the only warranty covering VektorFlo products. There are no other warranties covering VektorFlo products, neither expressed nor implied.

Vekttek, Inc. specifically disclaims any warranty of merchantability or fitness for a particular purpose.

When a question of warranty arises, the user must contact Vekttek, Inc. for authorization to return any product(s). All returned product(s) must display a Return Authorization number and be shipped to the address indicated on the Return Authorization form.

Returns

There is a minimum restocking fee on any return. All returns are subject to a progressive restocking fee. All returns must be pre-authorized, please call for a Return Authorization number. Any returned product not assigned a specific Return Authorization will be subject to disposal. Freight costs are to be prepaid and the evidence of delivery date furnished.