

APPLY LUBRICANT TO ALL SEALS PRIOR TO INSTALLATION. DO NOT USE SILICONE TYPE LUBRICANTS. FOR PROPER ARM MOUNTING SEE IS1505.

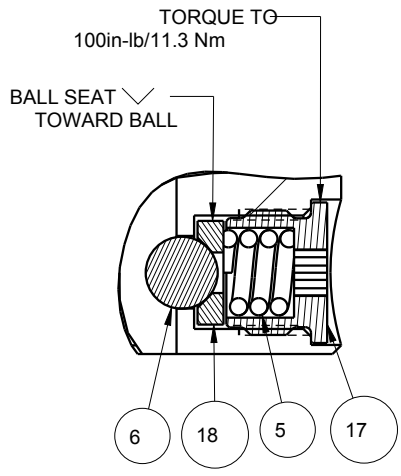

DETAIL A
SCALE 1.500

N/A	N/A	IS1505	INSTRUCTION SHEET, ARM INSTALLATION		
N/A	N/A	6V711032	SEAL KIT, FKM		
N/A	N/A	60711032	SEAL KIT, STANDARD		
19	1	81591827	CAM,SC,LP,22KN,RH,LS,TC		
18	3	81532108	SEAT, BALL, SC, LP, TC		
17	3	81532107	RETAINER, SC, LP, TC		
16	1	81531809	CAP, END, SC, LP, 22kN/5000		
15	1	81511812	PLUNGER,SC,LP,22KN,DA,LS,TC		
14	1	39054008	BU RING,(-218)	X	X
13	1	39054007	BU RING,(-030)	X	39054021
12	1	39053005	WIPER,SNAP-IN, (1-1/4)	X	X
11	1	39051042	O-RING, (-030)	X	39V01021
10	2	39050042	O-RING, (-011)	X	39051025
9	1	39011060	SEAL,BEVEL WHEEL INSERT,1-1/4 x1/8 x1-1/2	X	39052015
8	1	39011056	SEAL,CROWN,1-9/16x1-3/4x5/32	X	39V11056
7	2	30601144	PLUG, SOCH, SAE 4		
6	3	23650004	BALL,TUNGSTEN-CARBIDE,250		
5	3	23350066	SPRING, COMPRESSION		
4	2	21500200	WASHER		
3	3	21500031	SHCS, M5 x 0,8 x 14, ALY		
2	10	21500022	SHCS, M5 x .8-6G x 20, ALY		
1	2	21500019	SCREW, CAP, BTNH, M3 X 6, ALY		
No.	QTY	PART No.	DESCRIPTION	Std. Seal Kit	FKM Seal Kit

PARTS LIST



VEKTEK, INC.
1334 E. SIXTH AVE. P.O. BOX 625
EMPORIA, KS. 66801 U.S.A.

ASSEMBLIES AFFECTED
14061803
14061803F

SIZE
A
PL7189

REV
A

A	3434	RELEASE	JDW	05/01/18
REV	IN ACCORDANCE WITH ECN	EFFECTIVE DATE	REVISED BY	DATE
DRW BY:	JDW	DRAWING STATUS: Released		
DATE:	05/01/18	PRODUCTION APPROVED FOR RELEASED STATUS ONLY		

