

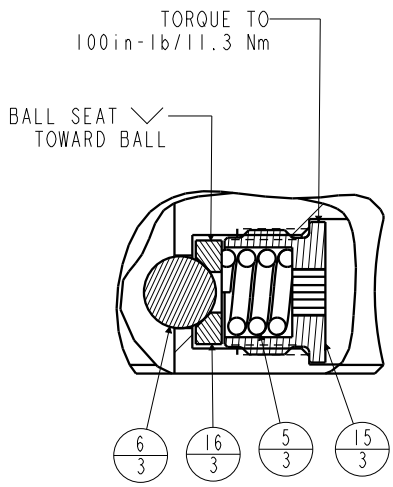

APPLY LUBRICANT TO ALL SEALS PRIOR TO INSTALLATION. DO NOT USE SILICONE TYPE LUBRICANTS. FOR PROPER ARM MOUNTING SEE IS1505.



DETAIL A SCALE 1.500

No.	QTY	PART No.	DESCRIPTION	Std. Seal Kit	FKM Seal Kit
N/A	N/A	IS1505	INSTRUCTION SHEET, ARM INSTALLATION		
N/A	N/A	6V711054	SEAL KIT, FKM		
N/A	N/A	60711054	SEAL KIT, STANDARD		
21	1	39V11051	WIPER, PRESS-IN, (1-1/2)	X	X
20	1	39V10029	WIPER, PRESS-IN, (1/4)	X	X
19	1	39H51002	O-RING, (-033)	X	39V51002
18	1	81592136	CAM, SC, LP, 7500/33KN, RH, LS, TC, PR		
17	1	81532115	CAP, END, SC, LP, 33KN/7500, PR		
16	3	81532108	SEAT, BALL, SC, LP, TC		
15	3	81532107	RETAINER, SC, LP, TC		
14	1	81500040	RING, LOCATOR, SC, LP, PR		
13	1	39054017	BU RING, (-033)	X	39054023
12	1	39054016	BU RING, (1.5x.125x.063)	X	X
11	1	39052043	SEAL, LL, (1/4 X 1/8 X 1/8 X 1/2)	X	39V52043
10	1	39052030	SEAL, CROWN, 1-3/4x2-1/8x1/4	X	39V52030
9	2	39050042	O-RING, (-011)	X	39051025
8	1	39011075	SEAL, LL, (1-1/2 X 1/8 X 1/8 1-3/4)	X	39V11075
7	2	30601144	PLUG, SOCH, SAE 4		
6	3	23650004	BALL, TUNGSTEN-CARBIDE. 250		
5	3	23350066	SPRING, COMPRESSION		
4	10	21500304	SHCS, M6 X 1.0-6G X 20MM		
3	2	21500200	WASHER		
2	3	21500031	SHCS, M5 X 0.8 X 14, ALY		
1	2	21500019	SCREW, CAP, BTNH, M3 X 6, ALY		

PARTS LIST	 VEKTEK VEKTEK, INC. 1334 E. SIXTH AVE. P.O. BOX 625 EMPORIA, KS. 66801 U.S.A.
	ASSEMBLIES AFFECTED 14062103PR 14062103FPR
PARTS LIST, ASSY, SC, LP, TC, TF, 7500, DA, RH, LS, PR	SIZE A
PL7204	REV C

C	5762	RELEASE	JDW	07/15/25
REV	IN ACCORDANCE WITH ECN	EFFECTIVE DATE	REVISED BY	DATE
DRW BY:	JDW	DRAWING STATUS: Released		
DATE:	10/16/13	PRODUCTION APPROVED FOR RELEASED STATUS ONLY		

