

APPLY LUBRICANT TO ALL SEALS PRIOR TO INSTALLATION. DO NOT USE SILICONE TYPE LUBRICANTS. FOR PROPER ARM MOUNTING SEE IS1505.

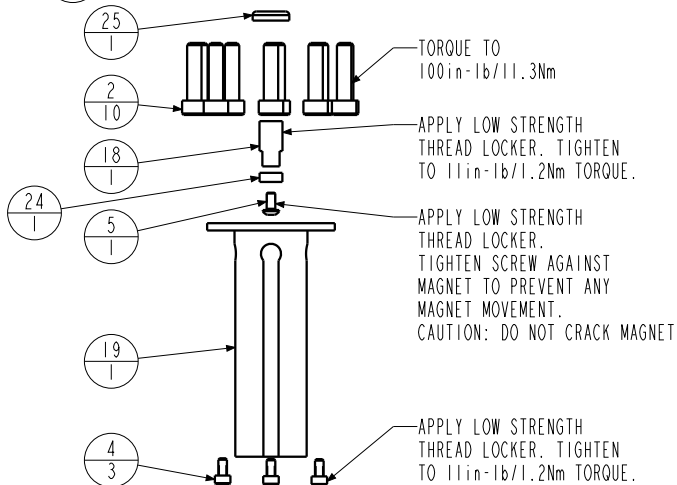

N/A	N/A	IS1505	INSTRUCTION SHEET, ARM INSTALLATION		
N/A	N/A	6V711052	SEAL KIT, FKM		
N/A	N/A	60711052	SEAL KIT, STANDARD		
25	1	39V10029	WIPER, PRESS-IN, (1/4)	X	X
24	1	91100001	MAGNET, .130 x .312, PS		
23	1	81591838	CAM, SC, LP, 22KN, LH, LS, TC, PR		
22	3	81532108	SEAT, BALL, SC, LP, TC		
21	3	81532107	RETAINER, SC, LP, TC		
20	1	81531819	CAP, END, SC, LP, 22KN/5000, PR		
19	1	81500062	HOUSING, PS, MAG, SC, LP, LS		
18	1	81500060	ADAPTOR, PS, MAG, SC, LP		
17	1	39054008	BU RING, (-218)	X	X
16	1	39054007	BU RING, (-030)	X	390540021
15	1	39053005	WIPER, SNAP-IN, (1-1/4)	X	X
14	1	39052043	SEAL, LL, (1/4 X 1/8 X 1/8 X 1/2)	X	39V52043
13	1	39051042	O-RING, (-030)	X	39V01021
12	2	39050042	O-RING, (-011)	X	39051025
11	1	39011060	SEAL, BEVEL WHEEL INSERT, 1-1/4 x 1/8 x 1-1/2	X	39052015
10	1	39011056	SEAL, CROWN, 1-9/16 x 1-3/4 x 5/32	X	39V11056
9	2	30601144	PLUG, SOCH, SAE 4		
8	3	23650004	BALL, TUNGSTEN-CARBIDE. 250		
7	3	23350066	SPRING, COMPRESSION		
6	2	21500200	WASHER		
5	1	21500044	SCREW, CAP, BTNH, M3-0.5 X 6, SSTL		
4	3	21500043	SHCS, M3-0.5 X 6 ALY		
3	3	21500031	SHCS, M5 X 0.8 X 14, ALY		
2	10	21500022	SHCS, M5 X .8-66 X 20, ALY		
1	2	21500019	SCREW, CAP, BTNH, M3 X 6, ALY		
No.	QTY	PART No.	DESCRIPTION	Std Seal Kit	FKM Seal Kit

PARTS LIST

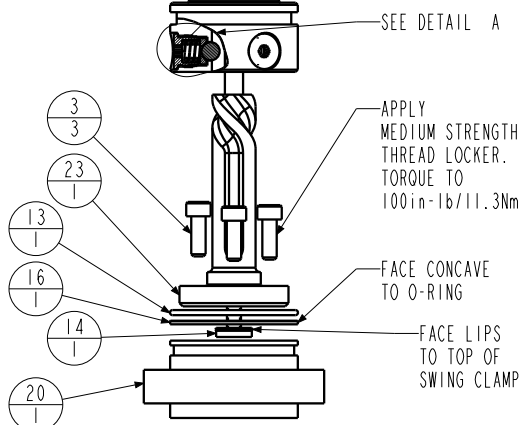
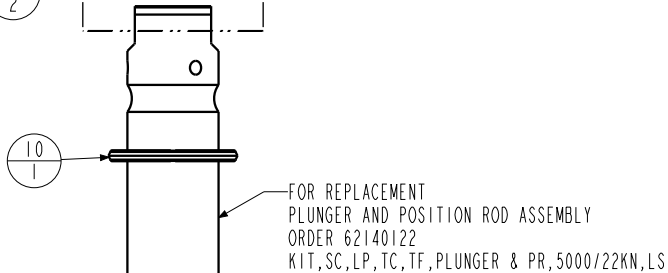
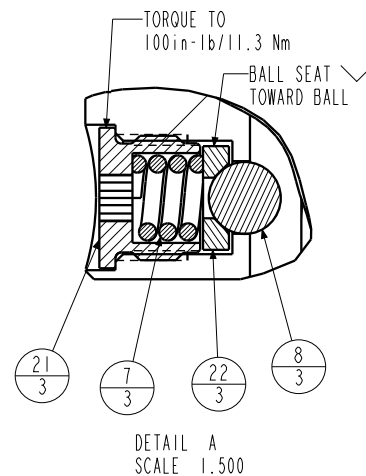

VEKTEK, INC.
1334 E. SIXTH AVE. P.O. BOX 625
EMPORIA, KS. 66801 U.S.A.

ASSEMBLIES AFFECTED

14061804PS
14061804FPS

PARTS LIST, ASSY, SC, LP, TC, TF, 5000, DA, LH, LS, PS

SIZE
A

PL7239

REV
C

SHEET 1 OF 1

C	5770	RELEASE	JDW	08/02/25
REV	IN ACCORDANCE WITH ECN	EFFECTIVE DATE	REVISED BY	DATE
DRW BY:	JDW	DRAWING STATUS: Released		
DATE:	06/01/18	PRODUCTION APPROVED FOR RELEASED STATUS ONLY		

